

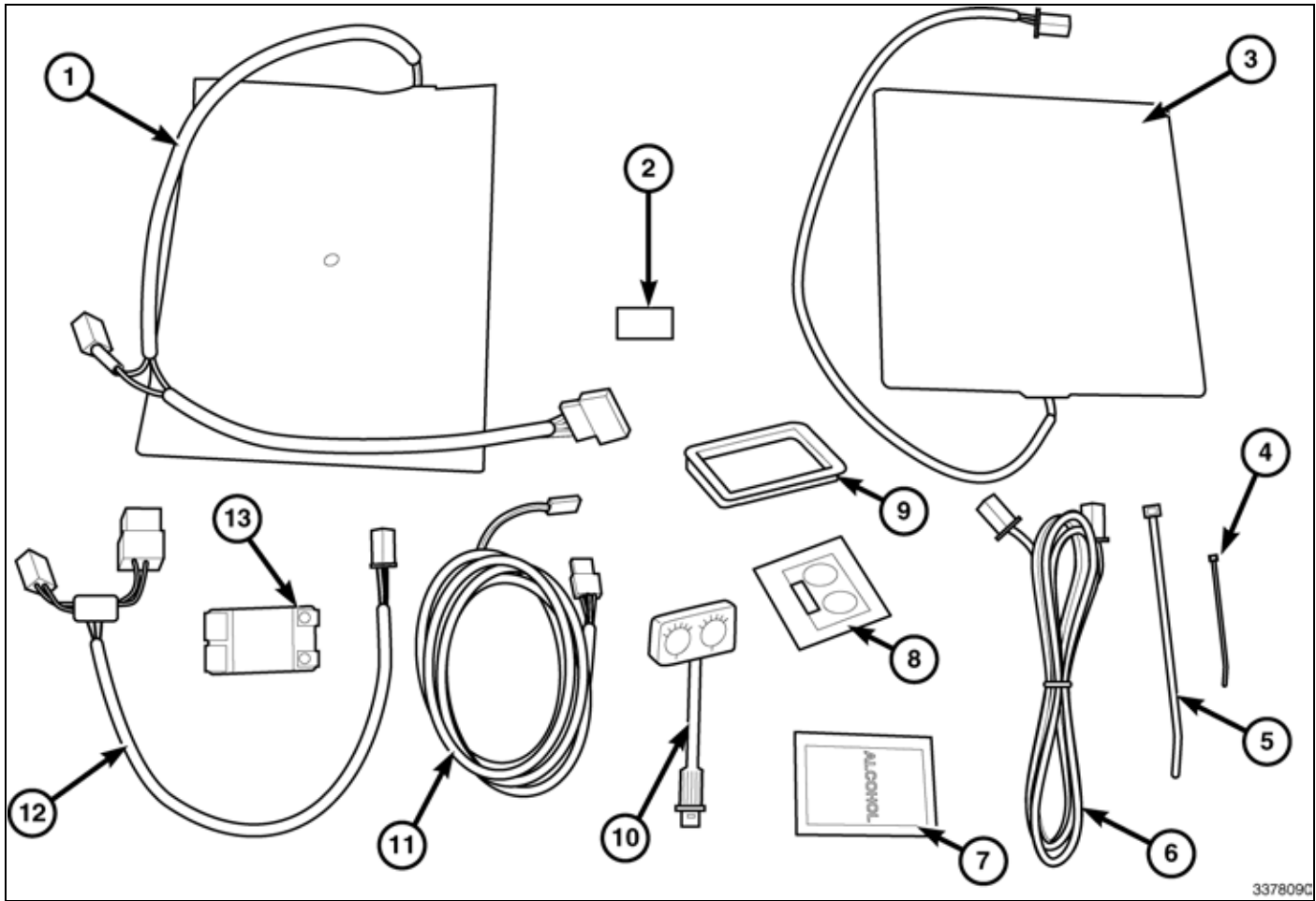

# FRONT HEATED SEATS

2011 > JEEP WRANGLER



337809C

| CALL OUT | DESCRIPTION                | QUANTITY |
|----------|----------------------------|----------|
| 1        | Cushion Heating Element    | 2        |
| 2        | Two Sided Tape             | 1        |
| 3        | Seat Heating Element       | 2        |
| 4        | Small Zip Tie              | 10       |
| 5        | Large Zip Tie              | 4        |
| 6        | Extension Harness          | 2        |
| 7        | Alcohol Pad                | 1        |
| 8        | Switch Template            | 1        |
| 9        | Switch Frame               | 1        |
| 10       | Heated Seat Switch         | 1        |
| 11       | Switch Harness             | 1        |
| 12       | Power Harness              | 1        |
| 13       | Heated Seat Control Module | 1        |

| Tools Required                                 |                                 |                          |
|--|---------------------------------|--------------------------|
| 7mm, 10 mm, 15mm, and 18mm Sockets and Ratchet | Trim Stick C-4755 or equivalent | Torx® T40 Bit and Driver |
| Ruler or Other Measuring Device                | Side Cutters                    | Hog Ring Pliers          |
| Dremel® or Similar Device                      | Marker                          | Torque Wrench            |

#### PROCEDURE STEPS:

**WARNING:** To avoid serious or fatal injury on vehicles equipped with airbags, disable the Supplemental Restraint System (SRS) before attempting any steering wheel, steering column, airbag, seat belt tensioner, impact sensor or instrument panel component diagnosis or service. Disconnect and isolate the battery negative (ground) cable, then wait two minutes for the system capacitor to discharge before performing further diagnosis or service. This is the only sure way to disable the SRS. Failure to take the proper precautions could result in accidental airbag deployment.

**WARNING:** The Seat Weight Sensor is a sensitive, calibrated unit and must be handled carefully. Do not drop or handle roughly. If dropped or damaged, replace with another sensor. Failure to follow these instructions may result in personal injury or death.

**WARNING:** The front passenger seat must be handled carefully as well. When removing the seat, be careful when setting on floor not to drop. If dropped, the sensor may be inoperative. Failure to follow these instructions may result in personal injury or death.

**WARNING:** When the seat is on the floor, no one should sit in the front passenger seat. This uneven force may damage the sensing ability of the seat weight sensors. If sat on and damaged, the sensor may be inoperative. Failure to follow these instructions may result in personal injury or death.

#### SEAT REMOVAL AND DISASSEMBLY

**NOTE:** Step #1 through Step #15 must be performed on the driver and passenger front seats.

1. Remove the four seat bolts (2).
2. Tip the seat back and disconnect the electrical connectors (3).
3. Remove the seat.

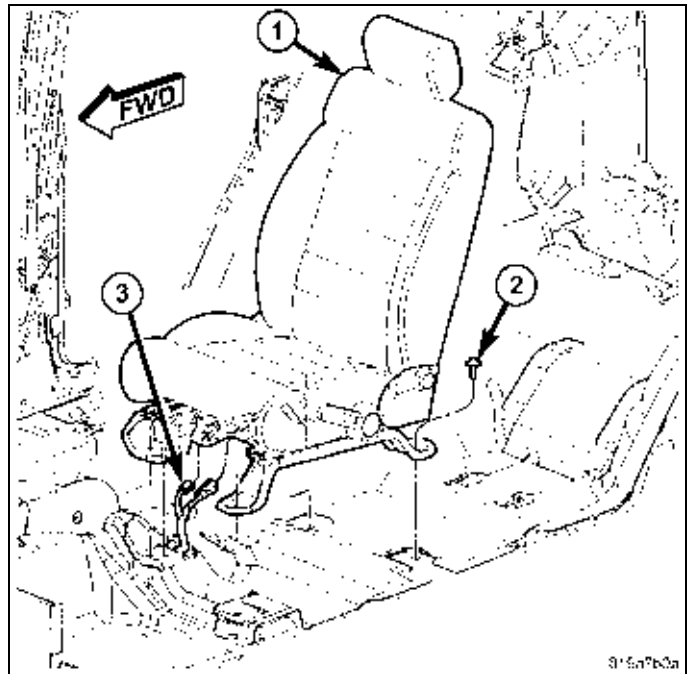

4. Place the seat on a flat surface.
5. Remove the cover from the lift handle (1) and remove the retaining screw (2). Remove the lift handle (1) from the seat.
6. Remove the clip that holds the reclining handle (3) to the seat and remove the handle from the seat.

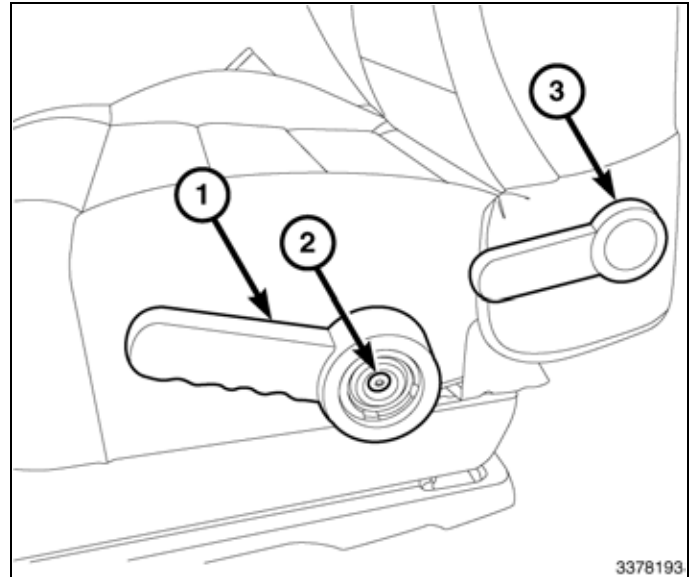

**NOTE: Driver side shown, passenger similar.**

7. Cut the zip-tie (1) between the seat frame and the J-channel on the seat cover. Pay close attention to how the zip-tie is routed to aid in installation.

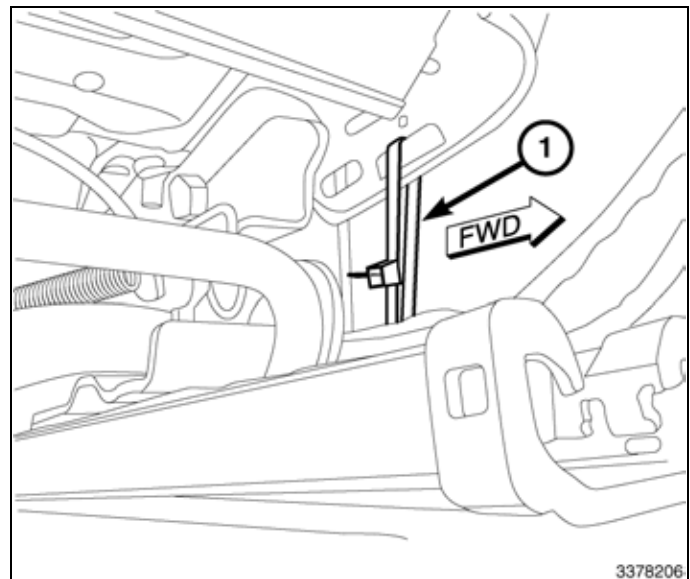

**NOTE: The two steps below must be performed on each side of the seat before the seat back can be separated from the lower seat frame.**

8. Position the seat cover (1) aside to expose bolts (2).
9. Remove bolts (2) that attach the seat back to the lower seat frame.

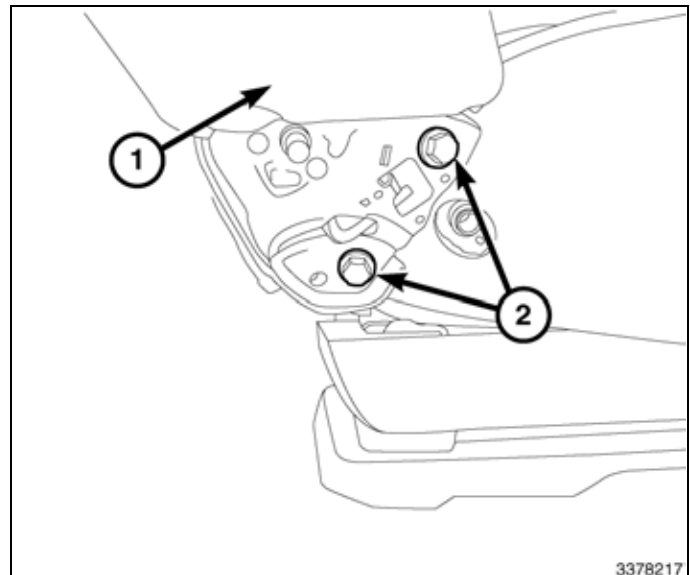

10. Disconnect the clip (4) that holds the flap (1) over the bottom of the seat.
11. Remove the white channel (2) from the seat frame (3).

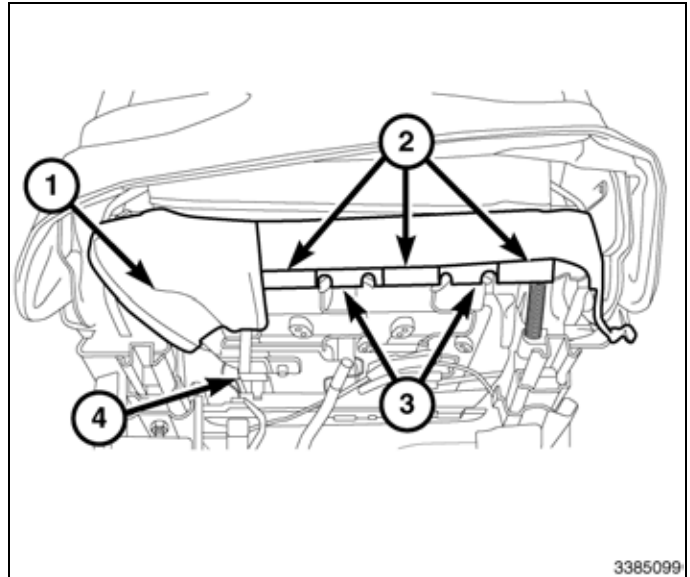

**NOTE: For the passenger seat, there is one cable on each side of the seat assembly.**

12. From the rear of the seat, disconnect the cable (2) from the bracket (1).
13. Separate the seat back and the lower seat.

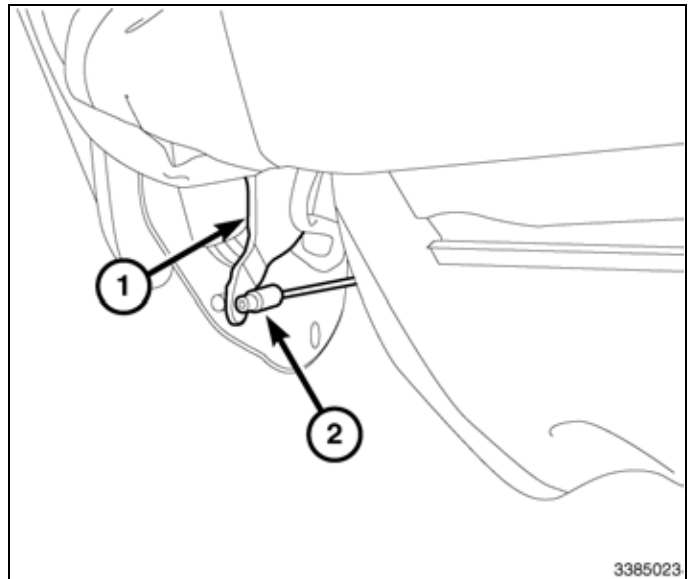

14. Remove the J-channel (1) from the seat frame (2) on both sides and the front of the seat.

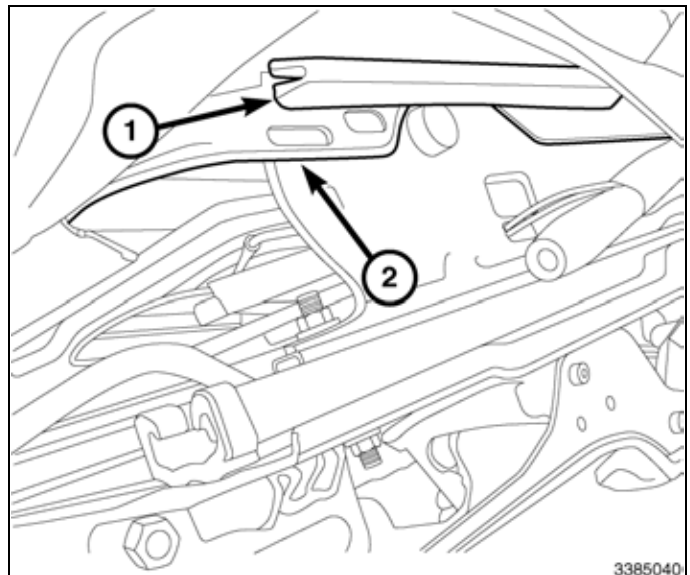

15. Separate the upper (1) and lower (2) J-channels on the seat back.

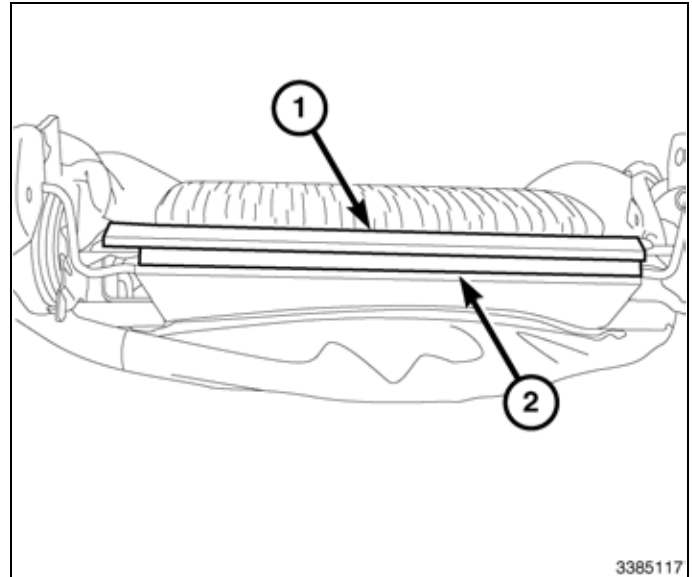

### DRIVER SEAT CUSHION ELEMENT INSTALL

16. Peel the seat cushion cover (1) from the seat cushion (3) and cut off hog rings (2).

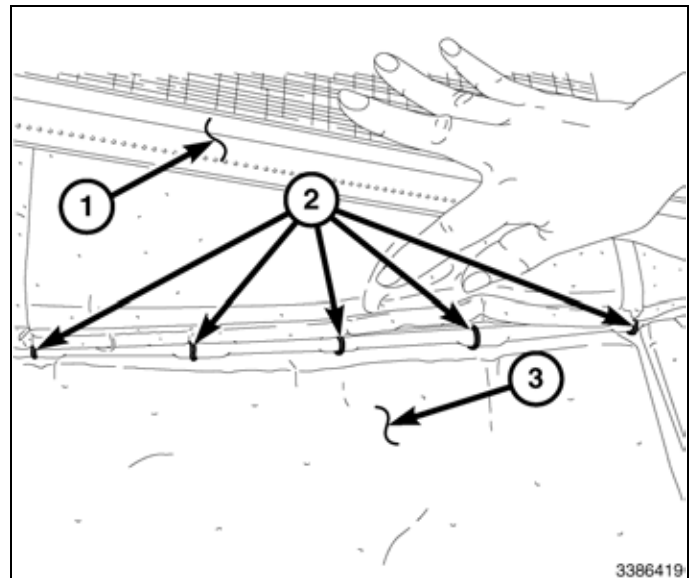

17. Continue to peel the cover from the cushion, removing hog rings (1) as they are exposed.

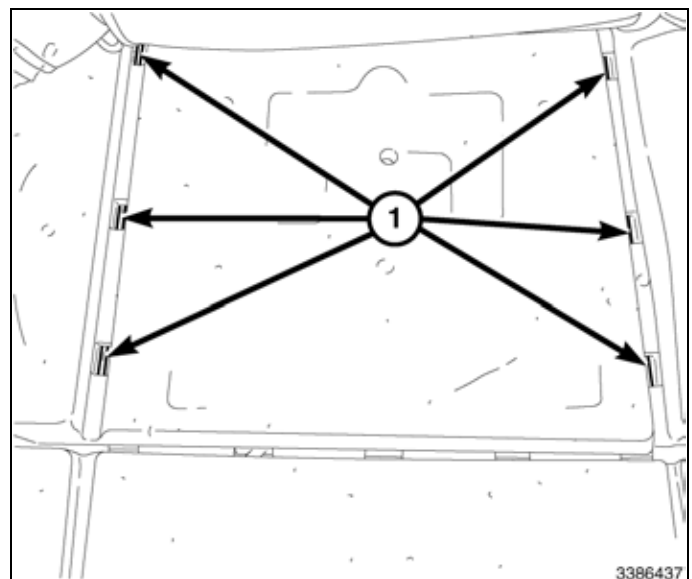

18. Position the cushion heating element (2) on the cushion and line up the hole in the element (1) with the hole in the cushion.
19. Make sure the front edge (3) of the heating element is parallel to the cushion tie down trench.
20. Once the position is determined, remove the adhesive backing from the heating element and press the element firmly into the correct position. Route the heating element wires out the back of the cushion.
21. Stretch the seat cover over the foam bun and heating element and install hog rings in the same locations as were removed.

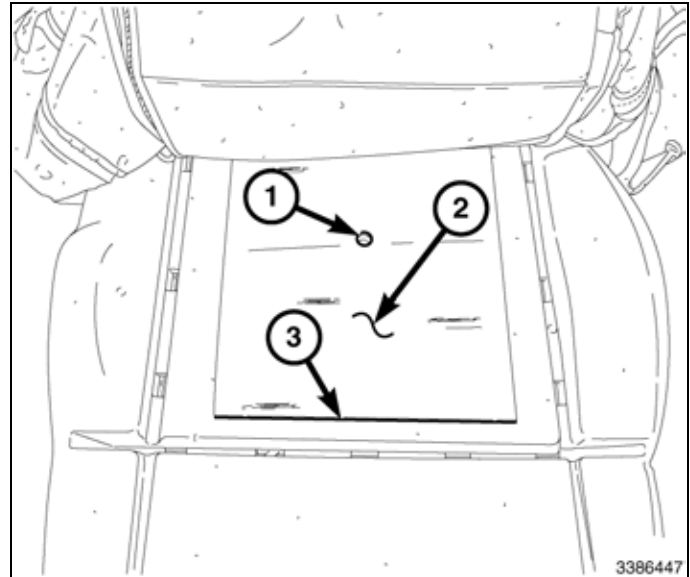

### PASSENGER SEAT CUSHION ELEMENT INSTALL

22. Continue to peel the cover from the cushion, removing hog rings (1) as they are exposed.
23. Carefully and gently lift the Occupant Detection Sensor (ODS) (2) from the cushion.

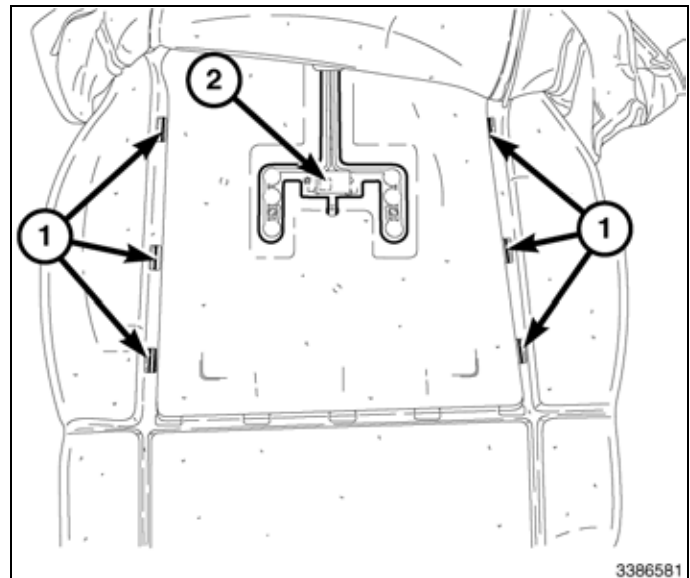

24. Position the seat heating element (1) on the cushion and align the hole in the element with the hole in the cushion (4). Make sure that the end of the element (3) is parallel with the cushion tie down trench.

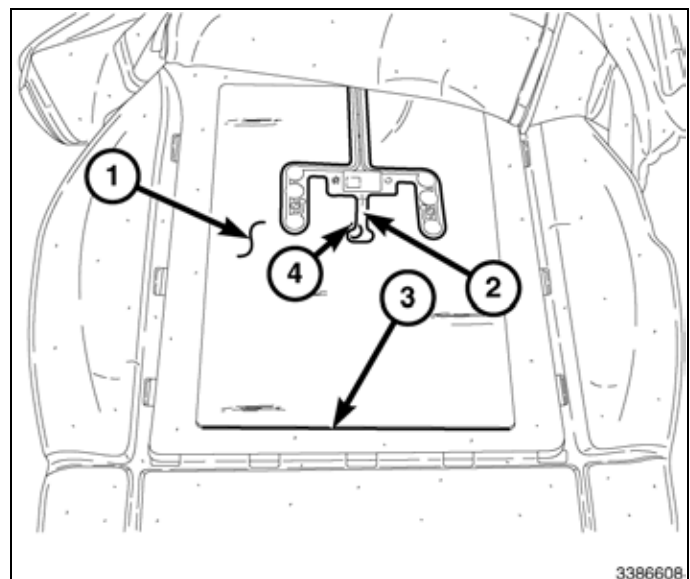

**NOTE: Before installing the new adhesive (1), the old adhesive must be peeled off of the ODS sensor.**

25. Remove the adhesive backing from one side of the patch of adhesive.
26. Carefully lift the Occupant Detection Sensor (ODS) (2) and place the patch of adhesive (1) on the ODS near the center.
27. Remove the other side of adhesive backing to prepare for the next step.

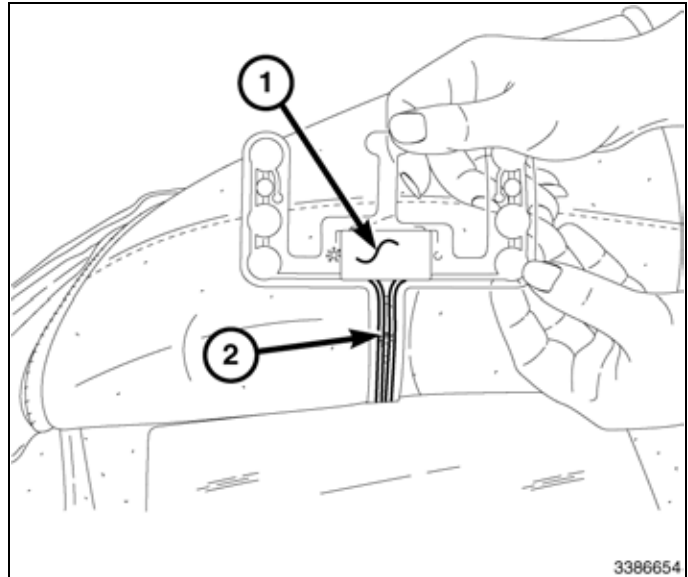

28. Place the Occupant Detection Sensor (ODS) (1) on the heating element and place the tab from the ODS into the hole (2) in the element and cushion. Align the right edge of the ODS with the center of the hole.
29. Gently press down to ensure the adhesive is in proper contact with the heating element.
30. Stretch the seat cover over the foam bun and heating element and install hog rings in the same locations as were removed.

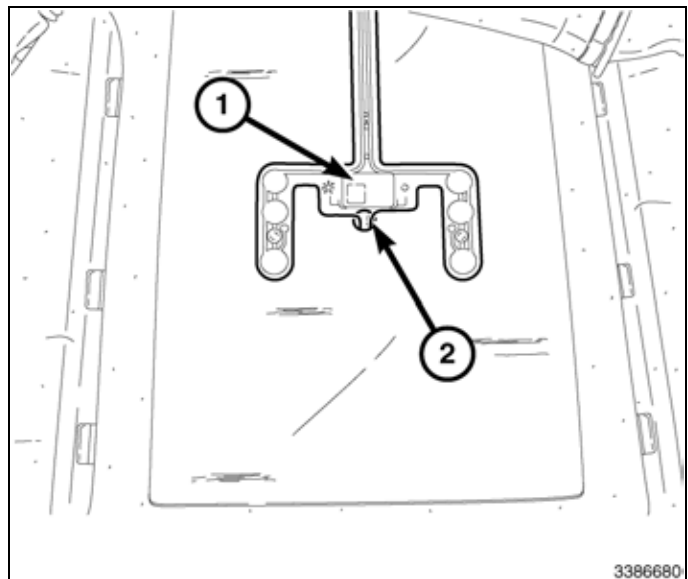

### SEAT BACK ELEMENT INSTALL

**NOTE: Step #31 to Step #34 must be performed on each seat.**

31. Roll the seat back cover (1) from the seat back foam bun (3), which is held together by velcro strips (2).

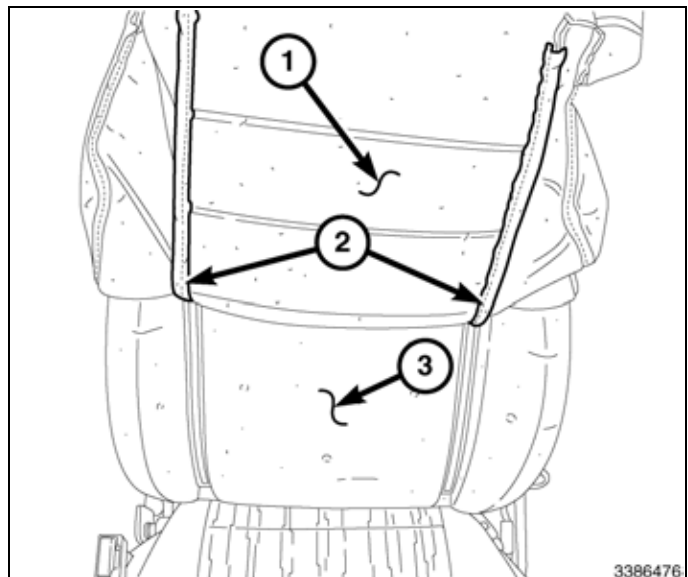

32. Position the seat back heating element (1) on the seat back foam bun so that there is 2.54 cm (1 in.) (2, 5) between the velcro and the element on each side, and 5 cm (2 in.) (4) from the bottom of the cushion to the element.
33. Once the element is in the measured position, remove the adhesive backing from the element and press firmly into position.
34. Route the heating element wiring (3) below the foam bun.

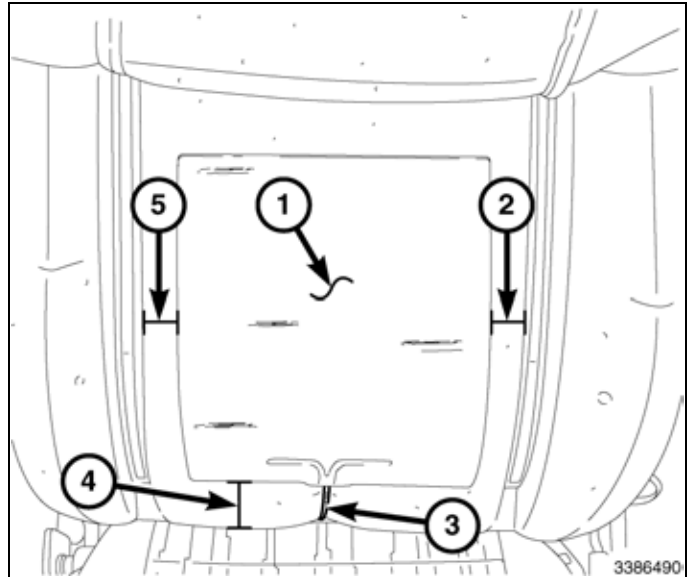

35. Roll the seat cover over the heating element and seat back foam bun (3), securing with the velcro strips (2).
36. Once installed, make sure to press on the velcro strips firmly to ensure the cover has no wrinkles.

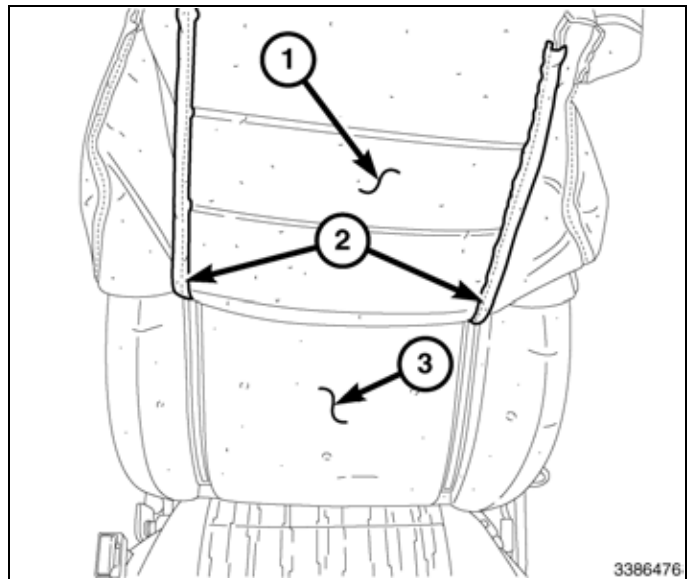

### REASSEMBLING THE SEAT

**NOTE: Step #37 to Step #47 must be performed on each front seat.**

37. Attach the upper (1) and lower (2) J-channels on the seat back.

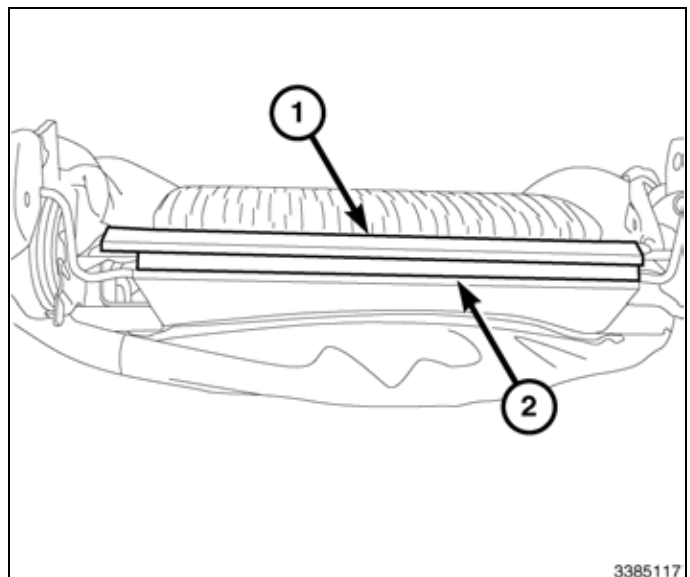



38. Connect the J-channel (1) to the seat frame (2) on both sides and the front of the seat.

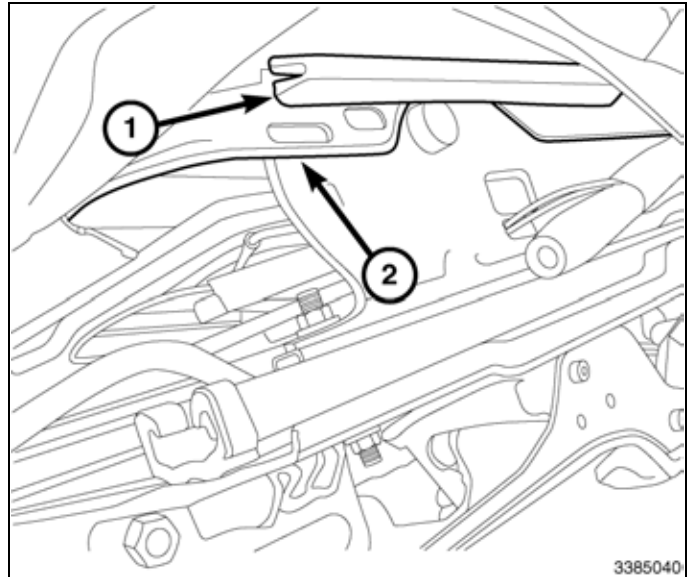

**NOTE: For the passenger seat, there is one cable on each side of the seat assembly.**

39. From the rear of the seat, connect the cable (2) to the bracket (1).
40. Attach the seat back and the lower seat.

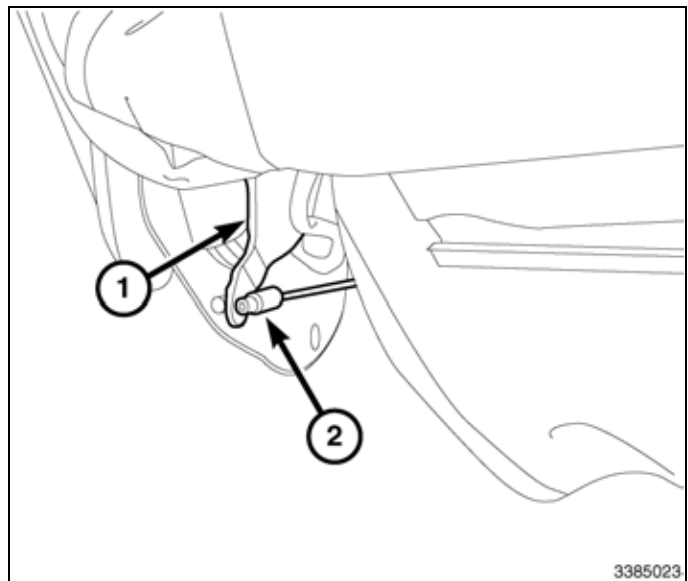

41. Connect the white channel (2) to the seat frame (3).
42. Connect the clip (4) that holds the flap (1) over the bottom of the seat.

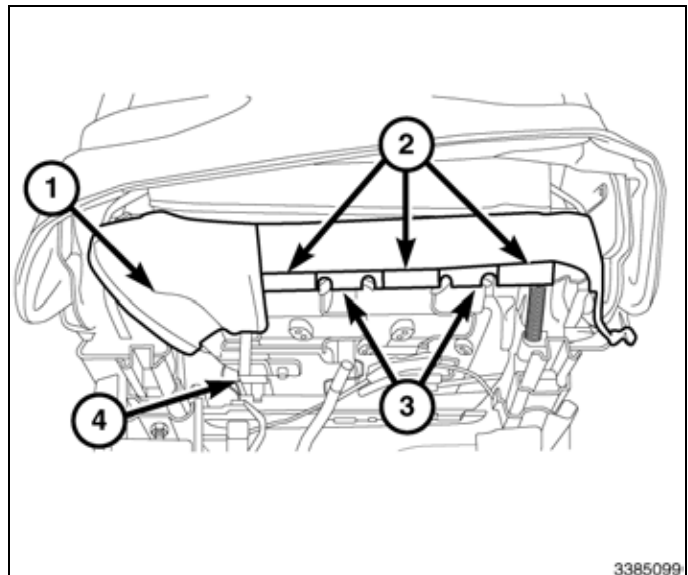

**NOTE: The following two steps must be completed on both sides of the seat.**

43. Install the bolts (2) that attach the seat back to the lower seat frame and tighten to 40 N·m (30 ft. lbs.).
44. Fold the seat cover (1) down to cover the bolts (2).

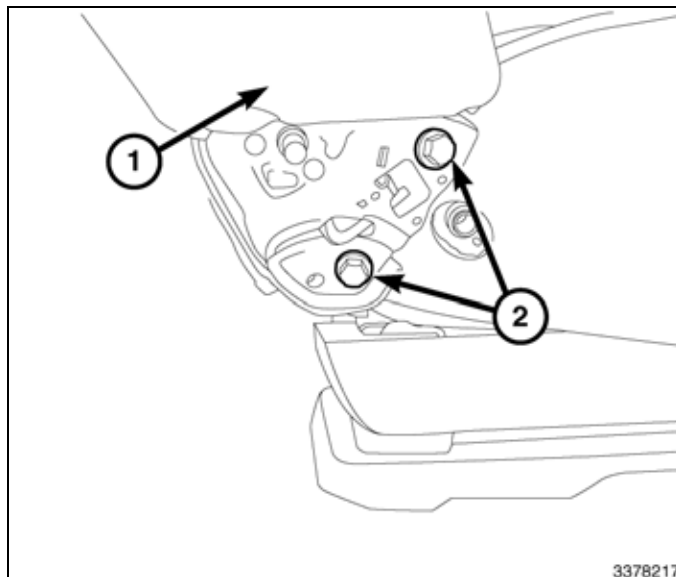

**NOTE: Driver side shown, passenger similar.**

45. Install the zip-tie (1) between the seat frame and the J-channel on the seat cover.

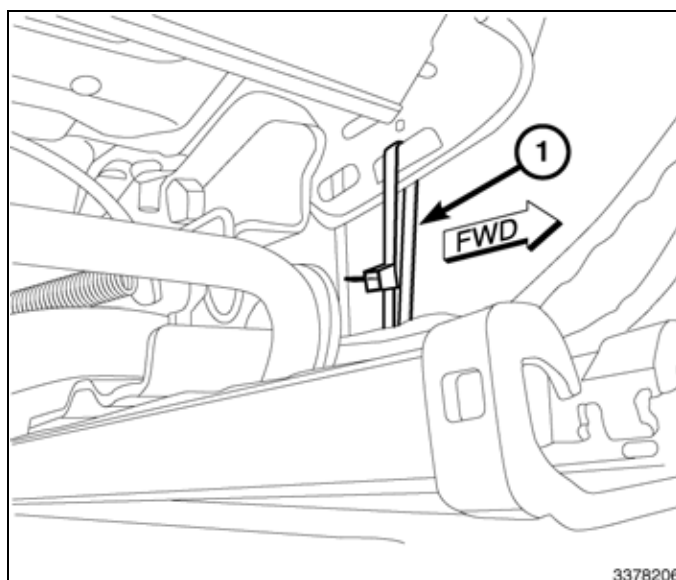

**NOTE: Driver side shown, passenger similar.**

46. Install the recliner handle (3) to the seat and install the retaining clip.
47. Install the lift handle (1) and install the retaining screw. Install the trim cover to the handle.

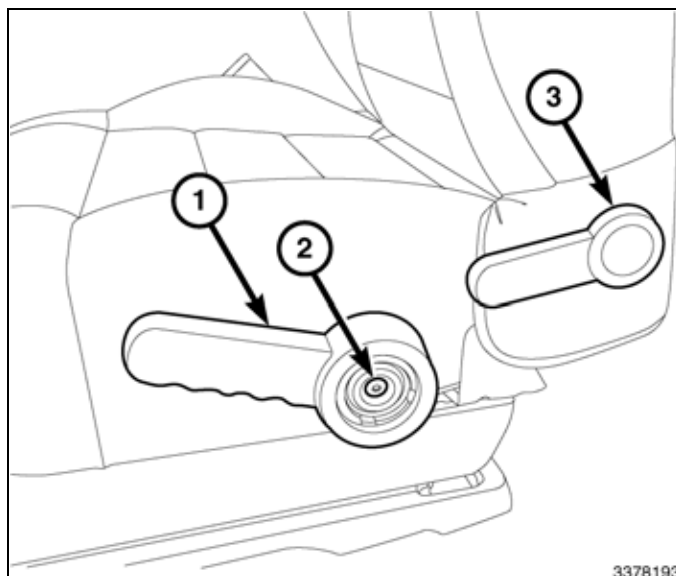

## WIRE ROUTING UNDER SEAT

**NOTE: Step #48 to Step #52 must be performed on each seat.**

48. Route the wires from the seat back heating element (1) and the wires from the seat cushion heating element (2) out of the back of the seat.
49. Connect the seat back connector to the seat cushion connector.

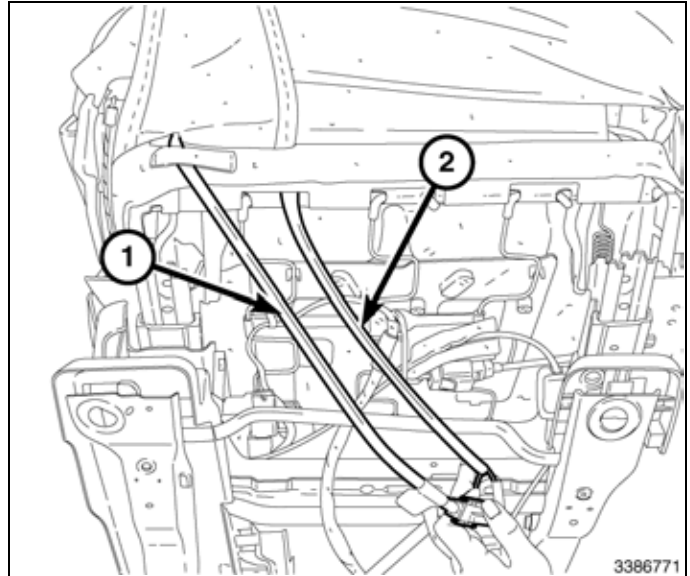

50. After connecting the two heating element connectors together, route the wires underneath the seat frame.
51. Route the wires along the existing wiring harness and secure with zip-ties (3, 4).
52. Replace the flap cover and attach clip (1) to the seat frame.

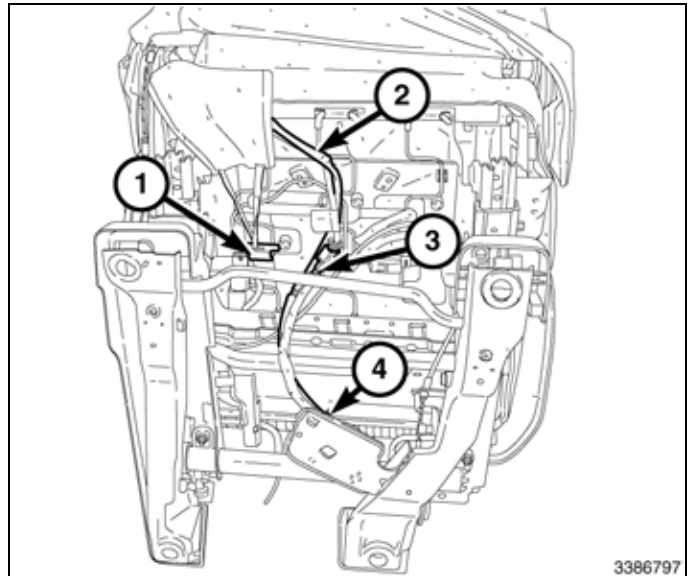

**SWITCH MOUNTING AND POWER HARNESS INSTALLATION**

53. Using a C-4755 trim stick or another equivalent, gently pry the edges of the instrument panel end cap trim panel (1) to remove.

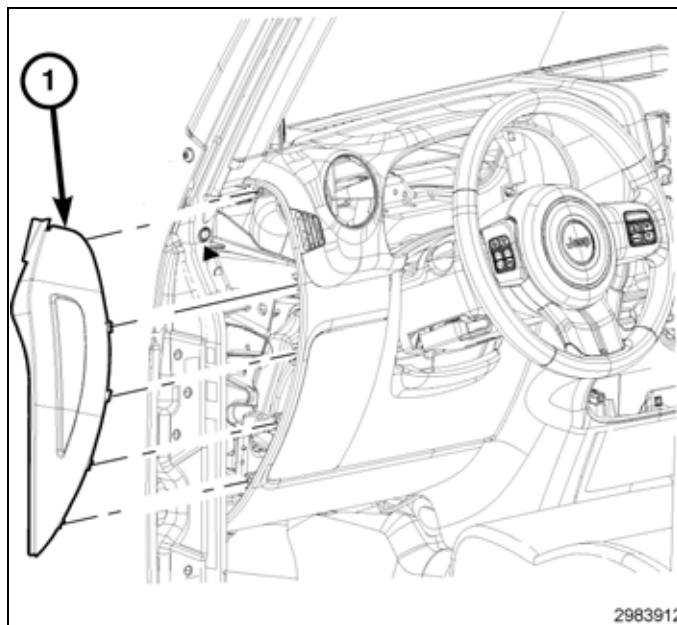

54. Using a C-4755 trim stick or another equivalent, gently pry the upper and lower edges of the knee blocker trim panel (1) to remove.

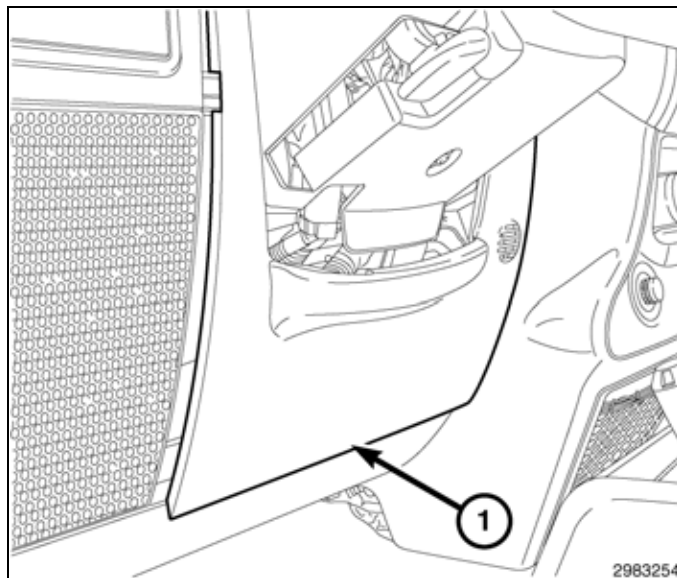

55. Remove the lower instrument cluster to I/P fastener (1) on the left hand side of the steering column.

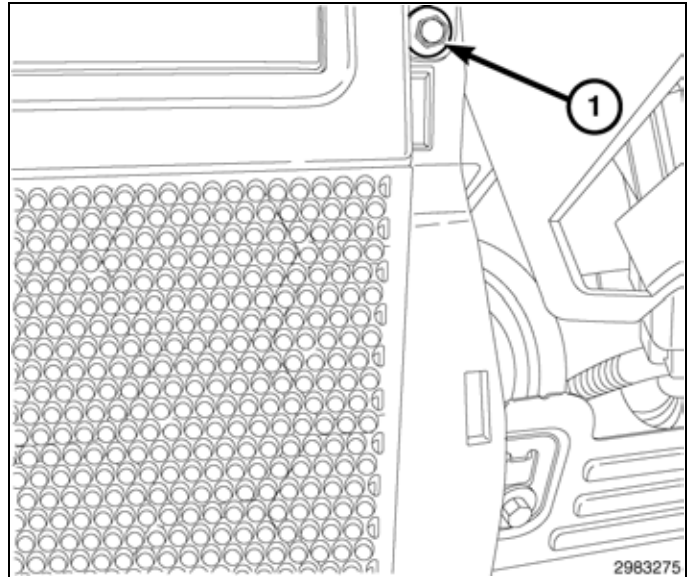

56. Remove the lower instrument cluster to I/P fastener (1) on the right hand side of the steering column.

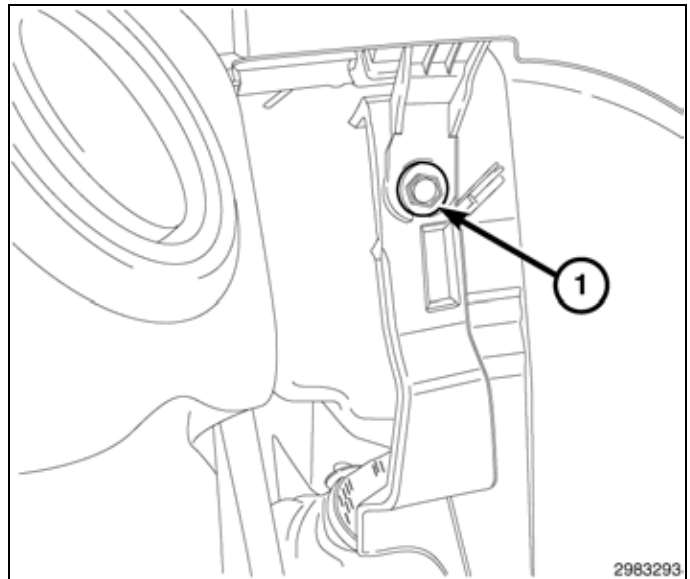

57. Remove the storage bin liner (1) located in the top center of the I/P.

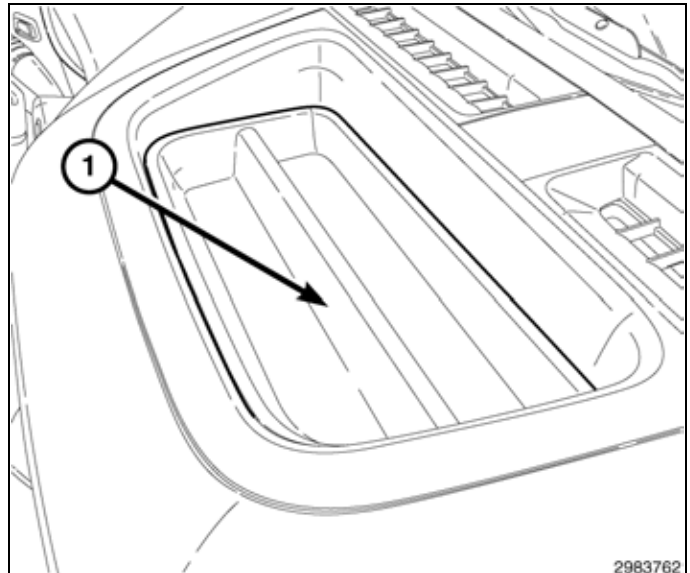

58. Remove the storage bin screw (1) from the top center of the I/P.

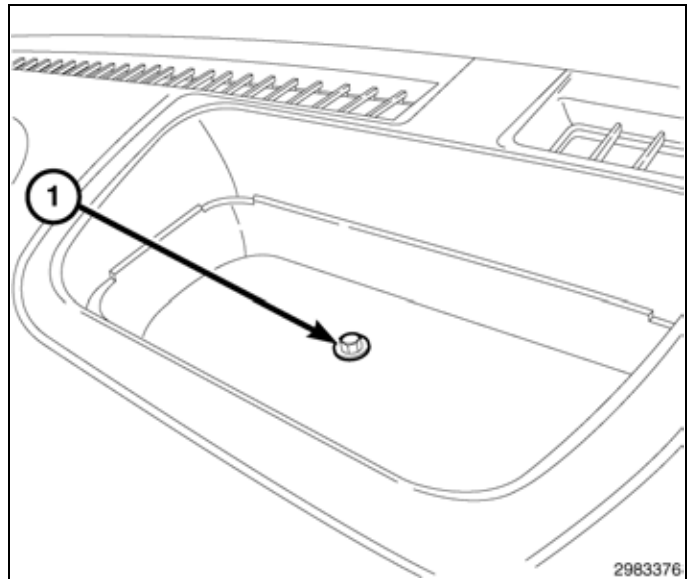

**NOTE: If the vehicle is equipped with power windows, the trim piece (1) is the window switch assembly.**

59. Using trim stick C-4755 or equivalent, gently pry the trim piece (1) away from the instrument cluster bezel.
60. If equipped with power windows, unlock the connector, disconnect the window switch assembly (1) and remove.

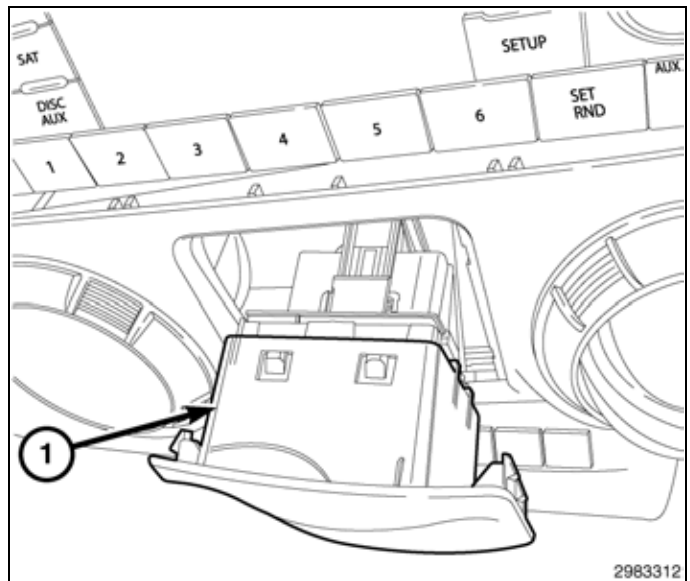

61. Remove the instrument cluster to I/P screw (1) located in the cavity.

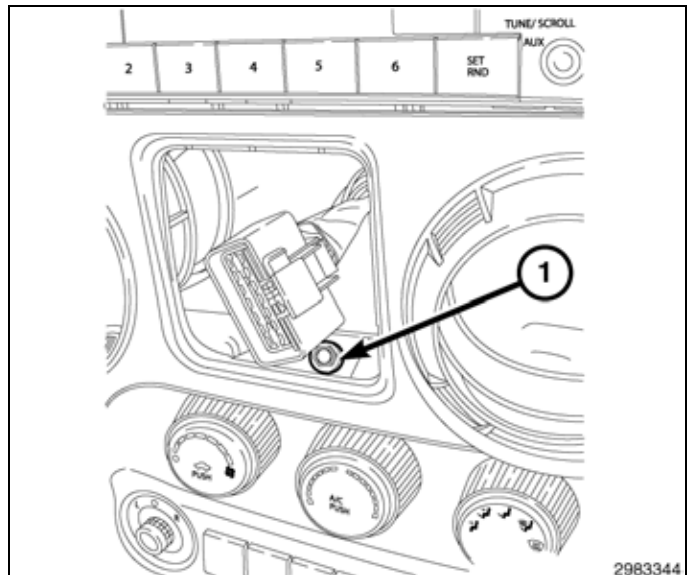

62. Using trim stick C-4755 or equivalent, gently pry the edges of instrument cluster bezel (1) away from the I/P to disengage the snap retainers.
63. Remove the instrument cluster bezel (1) from the I/P.

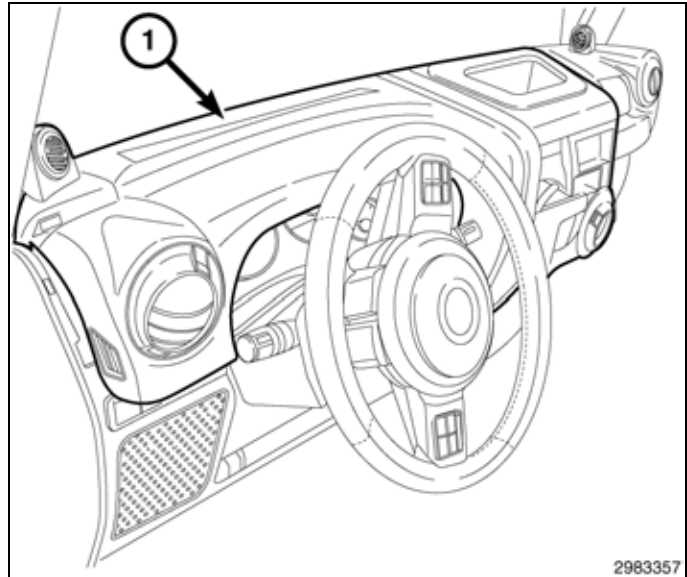

64. On manual transmission vehicles, using a trim stick C-4755 or equivalent, separate the shifter boot (2) from the console bezel (1).

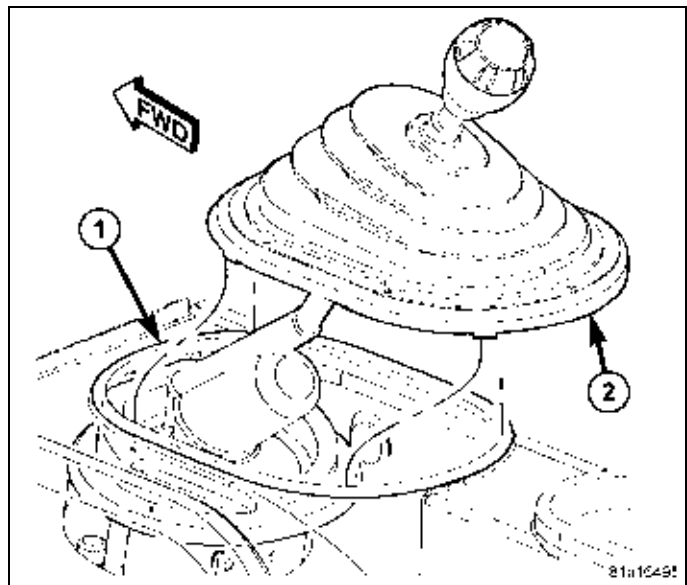

**NOTE: Most knobs can be removed by hand. The motion should mimic that of a slide hammer. Constant force doesn't aid in the removal of the knob.**

65. Slide the shift lever back towards the seat and pull in an upward motion with a "quick" snap to remove the knob.
66. If removal of the knob by hand is not possible wrap a shop towel or equivalent (4) around the base of the shift knob (3) and using puller C-4333A-1 or equivalent (2) and slide hammer (1), remove the shift knob from the shift lever.

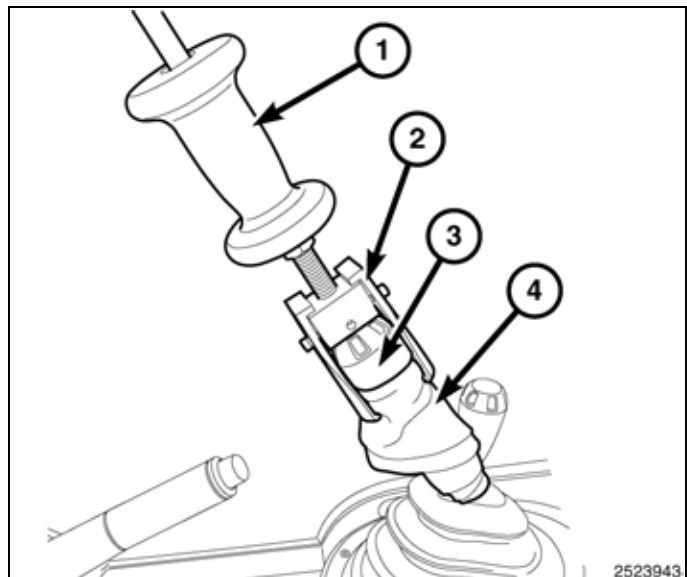

- 67. Remove the transfer case knob (1) by pulling in an upward motion with a "quick" snap to remove the knob.
- 68. Remove the cup holder or ash receiver, if equipped.
- 69. Using a trim stick C-4755 or equivalent, separate the retaining clips and remove the console bezel (2).

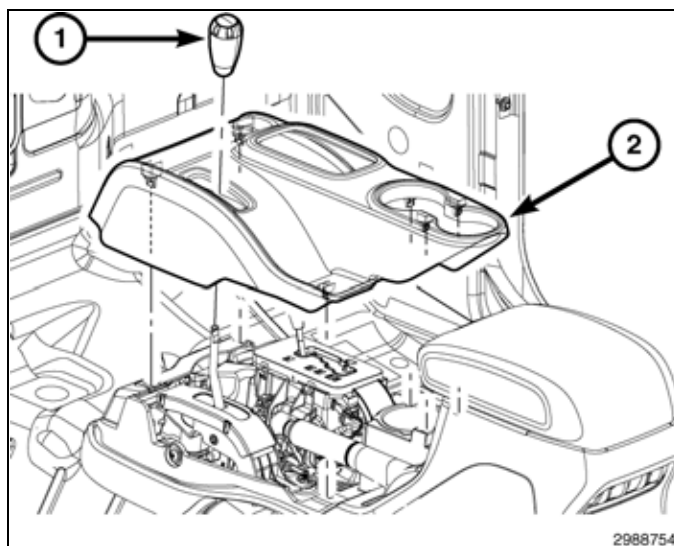

- 70. Using a trim stick C-4755 or equivalent, release the clips (2) and lower the center trim (1).
- 71. Disconnect the HVAC electrical connectors and remove the instrument panel center bezel (1).
- 72. Using a trim stick C-4755 or equivalent, remove the cargo net trim piece below the center bezel.

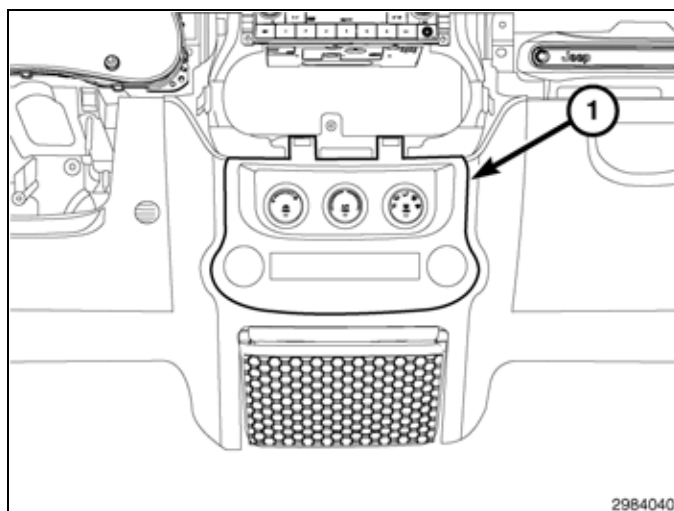

- 73. Connect the white factory connector (2) to the white power harness connector (3) that is included in the kit.
- 74. Connect the gray connector (1) from the power harness to the factory keyed 12V power outlet. The power wires (4) lead to the control module.

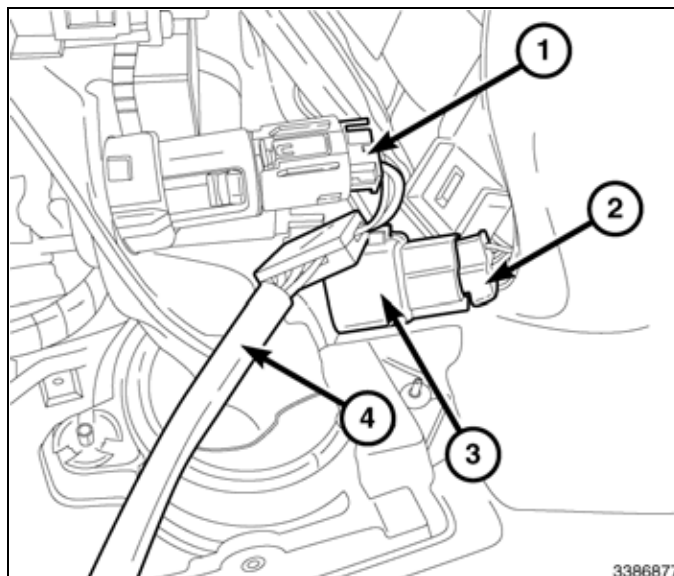



**NOTE: Driver side shown; passenger side similar.**

75. Route the extension harness (1) along existing wiring (2), securing with a zip-tie (3).
76. Tuck extension harness (5) underneath the carpet (4) and route into the opening for the center console.

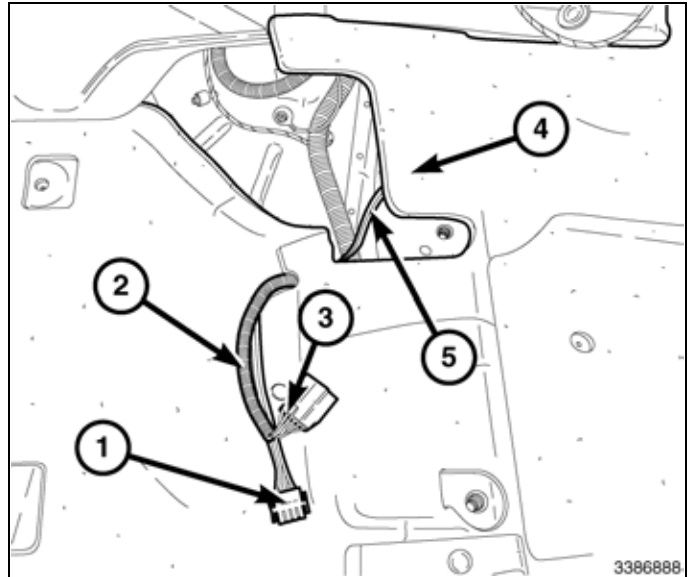

**NOTE: There is no cavity 2 on the control module.**

77. Attach each wire connector to the correct cavity on the control module as listed below:
  - a. Cavity 1 is the extension harness from the driver side seat.
  - b. Cavity 3 is the extension harness from the passenger side seat.
  - c. Cavity 4 is the power harness.
  - d. Cavity 5 is the switch harness.
78. Bunch up excess extension harness wiring (3) and arrange near existing wiring harness (4).
79. Using a large zip-tie (1), attach the control module (2) and excess extension harness wiring (3) to existing wiring harness.

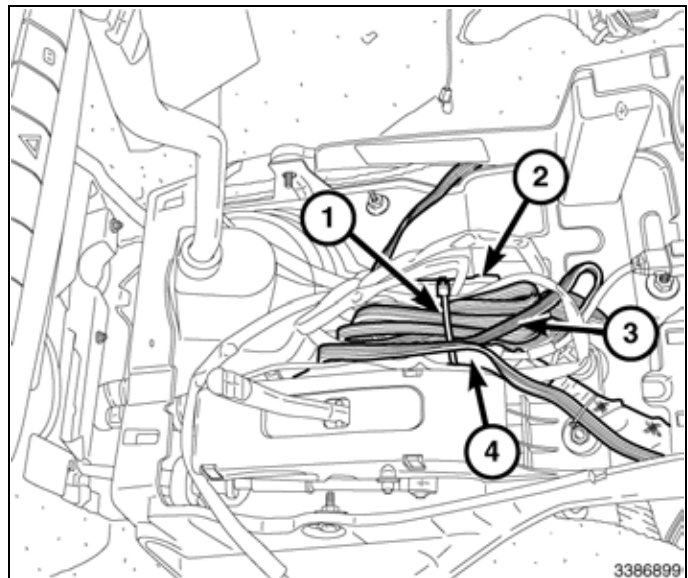

80. Place the console bezel on a flat bench.
81. Place the switch template (2) below the opening (1) for the transfer case shifter handle. Center the template between the sides of the console bezel and tape down.
82. Using a marker, mark the cutout section as shown with the dotted lines (3).
83. Remove the template and cut out the section that was marked. Clean the backside of the console bezel of any sharp edges.

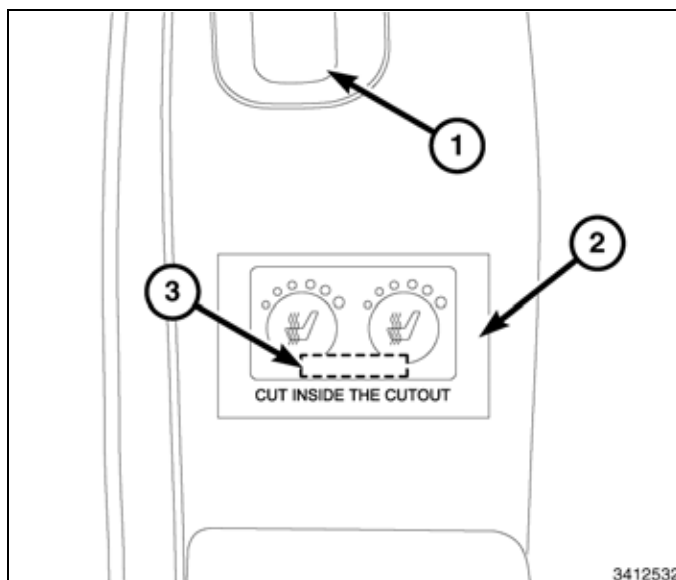

84. Obtain the switch and peel the adhesive backing from it, making sure to get the small strip below the ribbon.
85. Install the connector end of the switch through the hole that was previously cut in the console.
86. Make sure the switch is covering the hole that was cut and press the switch (1) down firmly on the console.

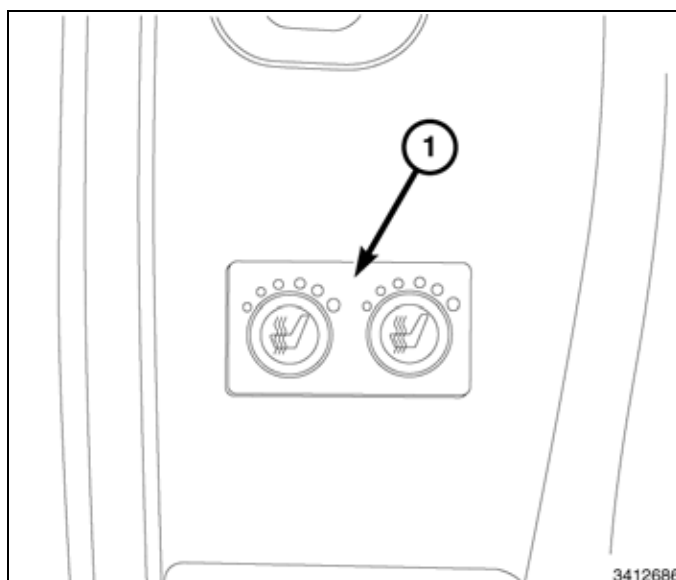

87. Remove the switch frame and place the frame (1) over the switch (2). Press the frame down firmly to ensure that it's secured to the console.

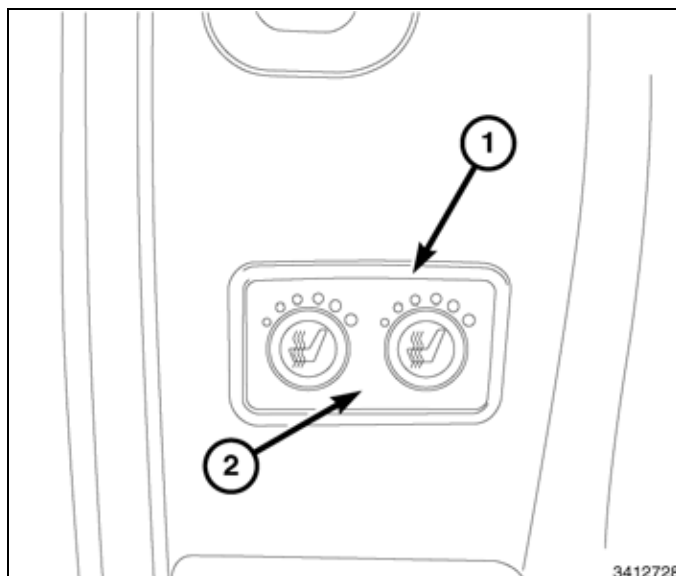

88. Position the instrument cluster bezel (1) to the I/P. Once aligned, apply pressure to engage the snap retainers.

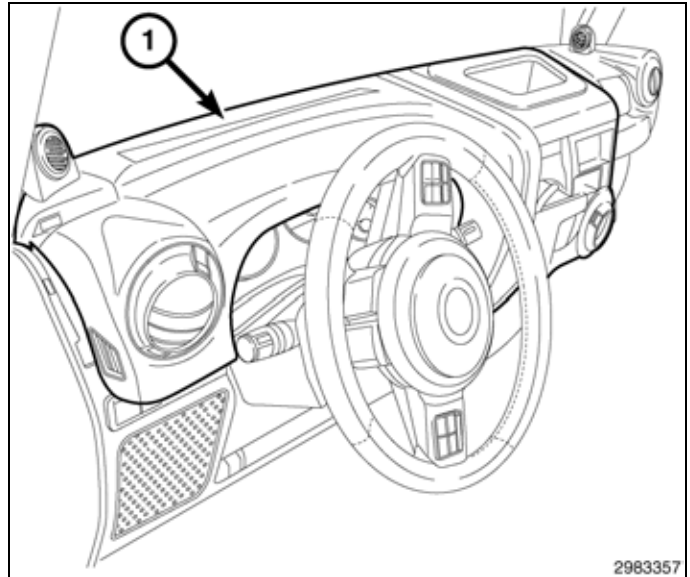

89. Install the instrument cluster to I/P screw (1) located in the cavity. Tighten the screw securely.

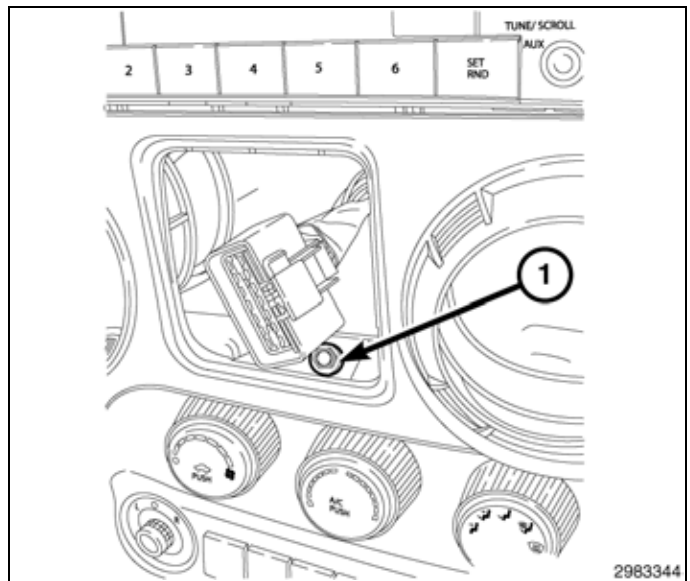

**NOTE: If the vehicle is equipped with power windows, the trim piece (1) is the window switch assembly.**

90. If equipped with power windows, connect the window switch to the harness and lock the connector.
91. Push the trim piece (1) into place. Make sure that all the retainers are fully engaged.

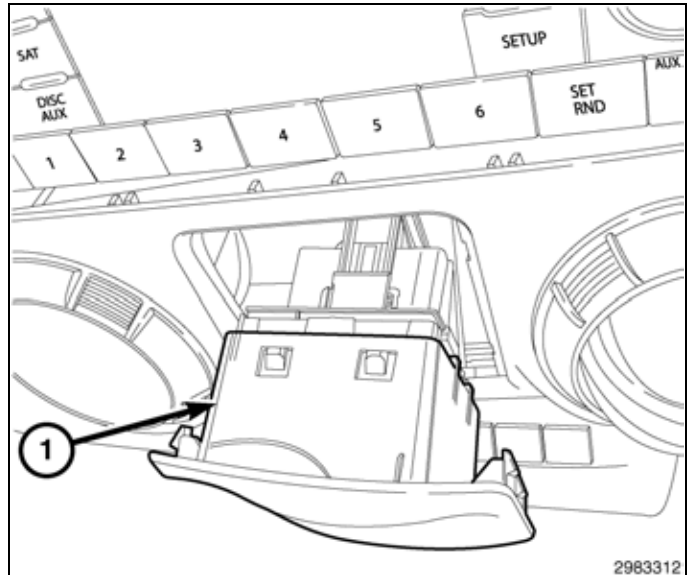

92. Install the storage bin screw (1) from the top center of the I/P. Tighten the screw securely.

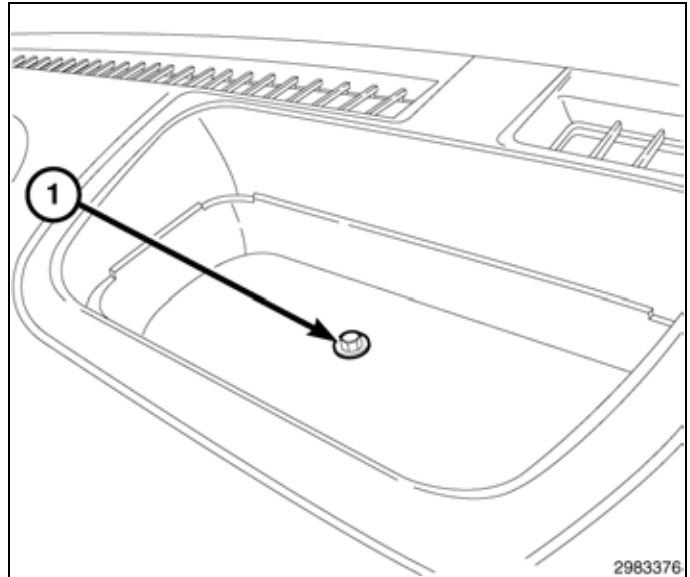

93. Install the storage bin liner (1) located in the top center of the I/P.

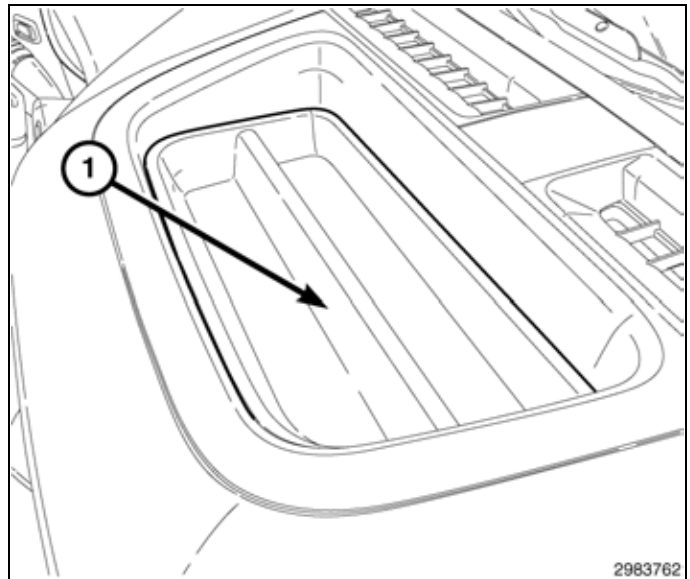

94. Install the lower instrument cluster to I/P fastener (1) on the right hand side of the steering column. Tighten the screw securely.

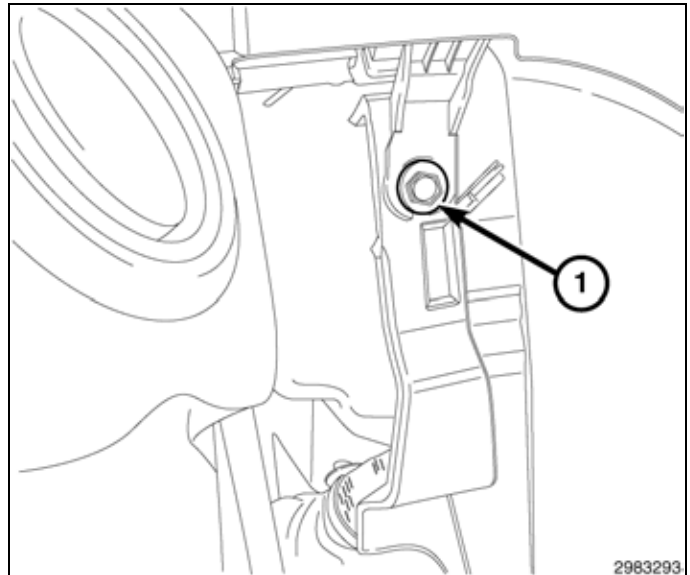

95. Install the lower instrument cluster to I/P fastener (1) on the left hand side of the steering column. Tighten the screw securely.

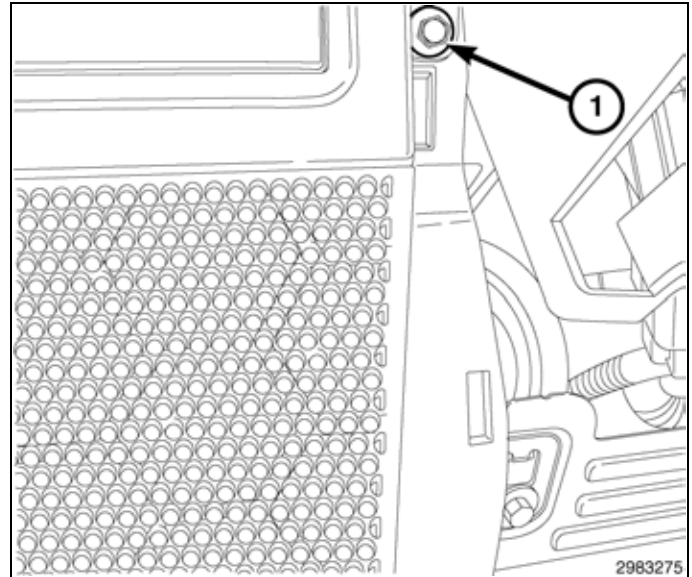

96. Push the upper and lower edges of the knee blocker trim panel (1) to install. Make sure the snap retainers are fully engaged.

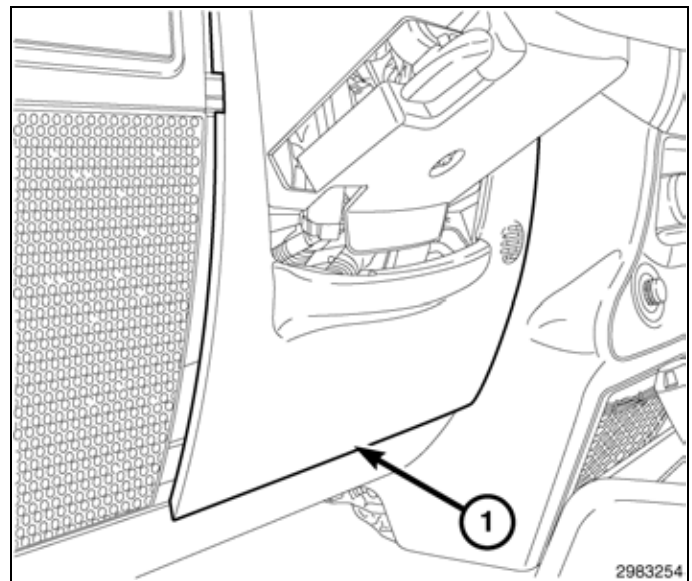

97. Push the edges of the instrument panel end cap trim panel (1) to install. Make sure the snap retainers are fully engaged.

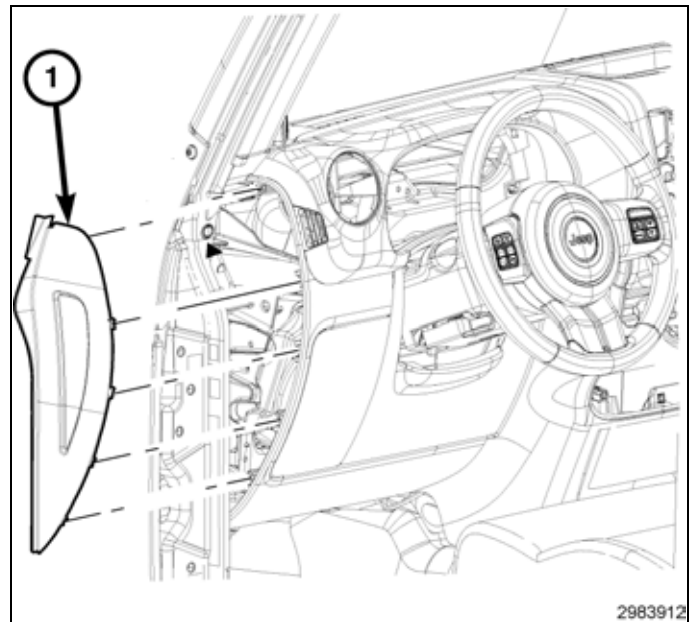

98. Connect the HVAC connectors and install the instrument panel center bezel (1).
99. Install the cargo net trim panel below the center bezel.

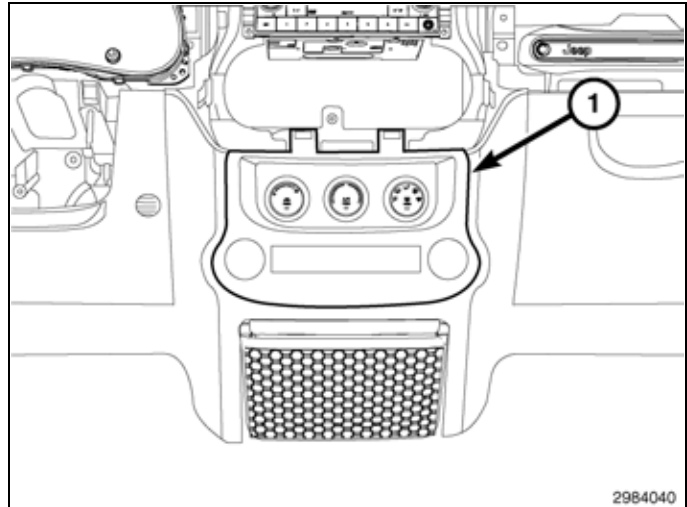

100. Install the bezel (2) over the shifters and seat the clips fully.
101. Install the cup holder and ash receiver, if equipped.
102. Position the transfer case shifter knob (1) onto the shift shaft, a audible click should be heard when the shifter knob is fully seated.

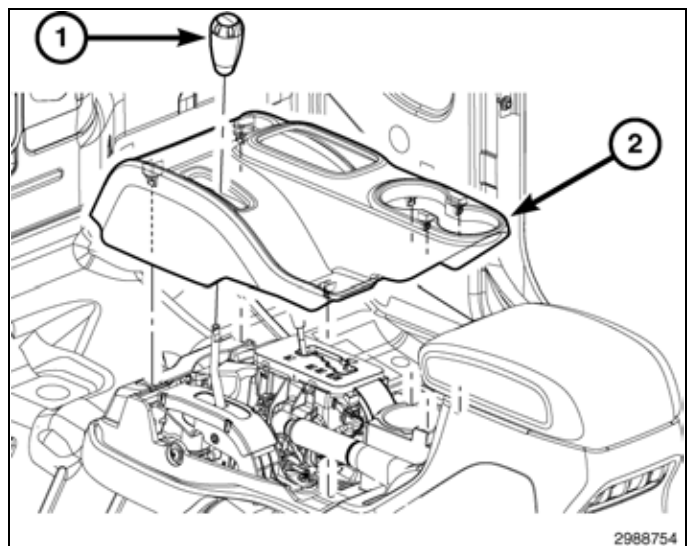

103. Seat the shifter boot (2) onto the console bezel (1) and seat fully.

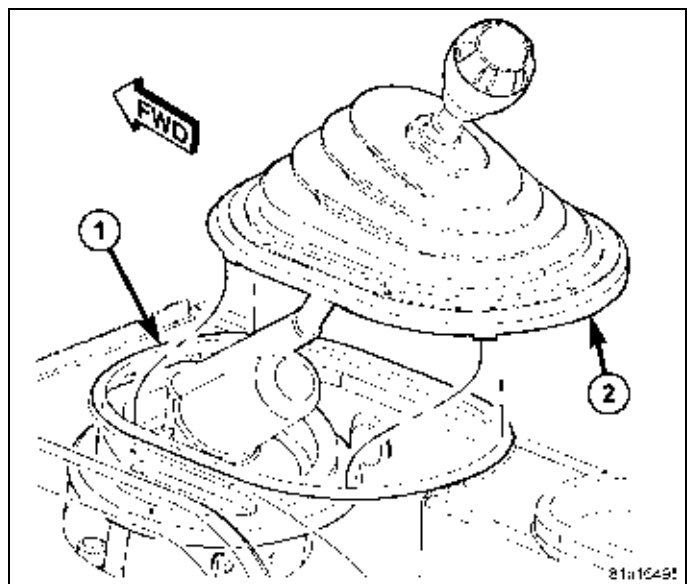

104. Install both front seats. Install four mounting bolts (2) and tighten to 65 N·m (48 ft. lbs.).
105. Connect extension harness to wiring installed under each seat, and connect any other electrical connectors.
106. Connect battery negative cable.
107. Ensure that the heating seats function properly.

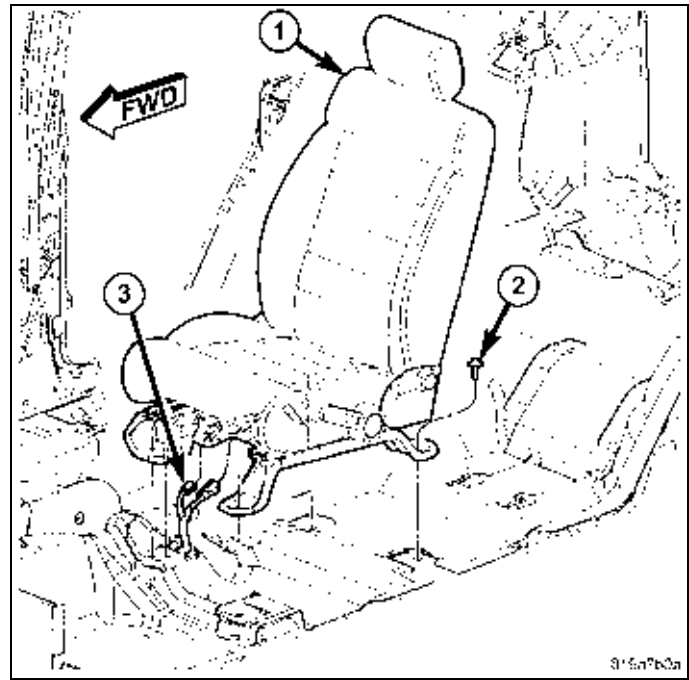

## WINDOW CALIBRATION

**NOTE: Vehicles equipped with the auto up feature must have the windows calibrated after a battery disconnect.**

**NOTE: The door must be completely closed when starting this step.**

1. Sit in the driver seat and close the door.
2. Lower the window part of the way down.
3. Run the window to the full up position and continue to hold the switch for an additional two seconds.
4. Run the window to the full down position and continue to hold the switch for an additional two seconds.
5. Raise the window to the full up position.
6. Repeat the steps for the remaining windows.