



SEAT BELT INSTALLATION SHEET K6855937

FOR USE IN JEEP CHEROKEE (KL) VEHICLES

WARNING: To avoid serious or fatal injury on vehicles equipped with airbags, disable the Supplemental Restraint System (SRS) before attempting any steering wheel, steering column, airbag, Occupant Classification System (OCS), seat belt tensioner, impact sensor or instrument panel component diagnosis or service. Disconnect and isolate the battery negative (ground) cable, then wait two minutes for the system capacitor to discharge before performing further diagnosis or service. This is the only sure way to disable the SRS. Failure to follow these instructions may result in accidental airbag deployment.

WARNING: To avoid serious or fatal injury during and following any seat belt or child restraint anchor service, carefully inspect all seat belts, buckles, mounting hardware, retractors, tether straps, and anchors for proper installation, operation, or damage. Replace any belt that is cut, frayed, or torn. Straighten any belt that is twisted. Tighten any loose fasteners. Replace any belt that has a damaged or ineffective buckle or retractor. Replace any belt that has a bent or damaged latch plate or anchor plate. Replace any child restraint anchor or the unit to which the anchor is integral that has been bent or damaged. Never attempt to repair a seat belt or child restraint component. Always replace damaged or ineffective seat belt and child restraint components with the correct, new and unused replacement parts listed in the Chrysler Mopar® Parts Catalog. Failure to follow these instructions may result in possible serious or fatal injury.

WARNING: To avoid serious or fatal injury on vehicles equipped with the Occupant Classification System (OCS), do not modify the front passenger seat assembly or center floor console in any way. Do not use any prior year, subsequent year, secondary or aftermarket seat trim covers. At no time should any Supplemental Restraint System (SRS) or OCS component be modified or replaced with any part except those which are specified for the particular vehicle application in the Chrysler Mopar® Parts Catalog. Failure to observe these precautions could cause an OCS miscalibration condition, which may result in the passenger airbag failing to deploy when required or deploying when not required.

WARNING: To avoid serious or fatal injury, never strike or drop a seat weight sensor or the passenger side front seat assembly to which the sensors are secured as it can damage the sensors or affect their calibration. The seat weight sensors and the passenger side front seat assembly must be handled with care to avoid damage to the sensors. Do not sit upon or place any loads upon a passenger side front seat while it is removed from its mounts in or outside of the vehicle. If an individual sensor is dropped or damaged, replace the sensor with a new and unused unit. If a seat has been dropped during removal or loaded while removed from its mounts, replace each of the seat weight sensors with new and unused units. Failure to observe this warning could result in an accidental, incomplete, or improper passenger side front Supplemental Restraint System (SRS) component deployment.

WARNING: To avoid serious or fatal injury on vehicles equipped with the Occupant Classification System (OCS), any time the passenger side front seat assembly has been removed or loosened from the vehicle for service of any vehicle component or system the Occupant Classification System (OCS) Verification Test must be performed using a diagnostic scan tool and the Occupant Classification Seat Weight special tool following reinstallation. Refer to the appropriate diagnostic procedures. Failure to observe this warning could result in an accidental, incomplete, or improper passenger side front Supplemental Restraint System (SRS) component deployment.

1. Identify the illustration which best represents the replacement seat belt assembly contained in this package.
2. Remove any interior trim parts, remove or reposition seats, as necessary, to allow removal of the seat belt assembly.

For additional information, refer to the vehicle service manual.

3. Install the replacement seat belt assembly, taking care to route the belt through openings in the interior trim parts as necessary.
4. Tighten the seat belt assembly anchor bolts to the torque specified in each seat belt assembly graphic.
5. After seat belt installation, reinstall the interior trim parts and/or seats. **For additional information, refer to the vehicle service manual.**
6. Place this Installation Instruction in the vehicle glove box.

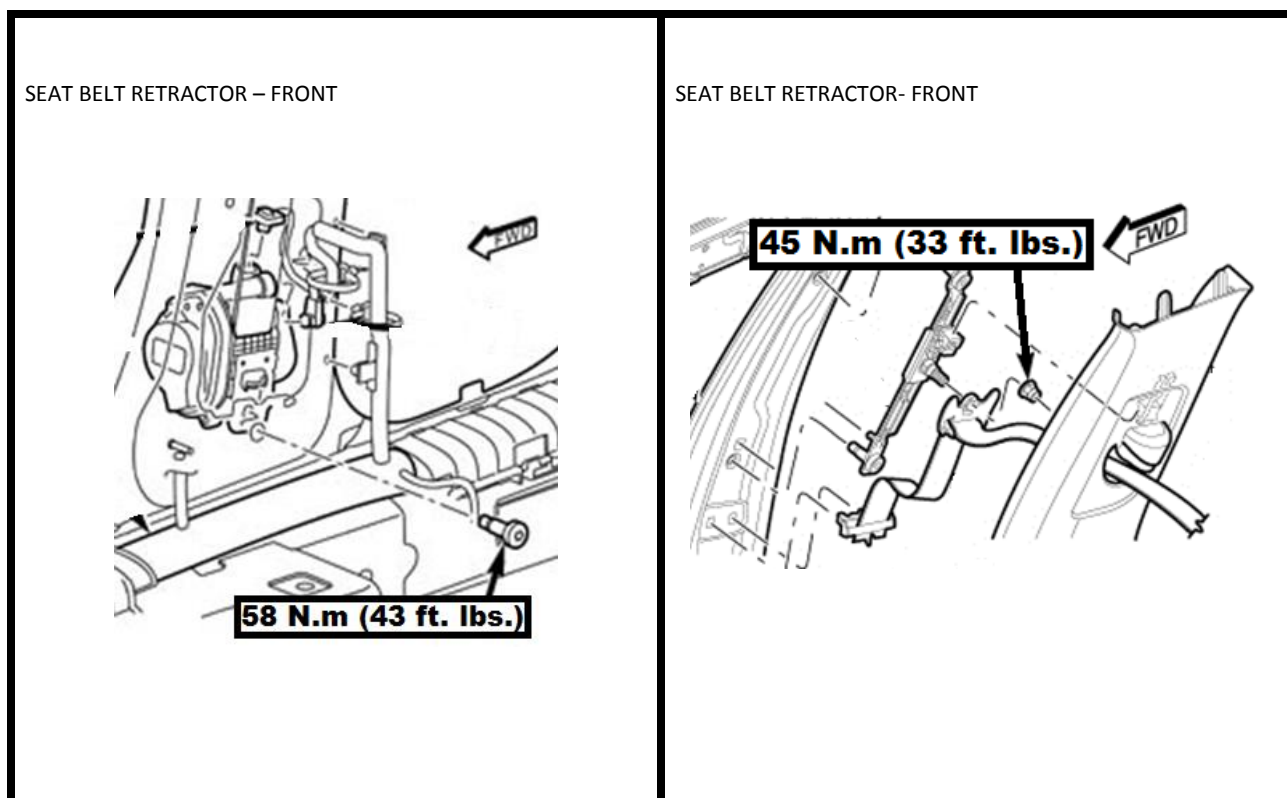

SEAT BELT RETRACTOR – REAR OUTBOARD

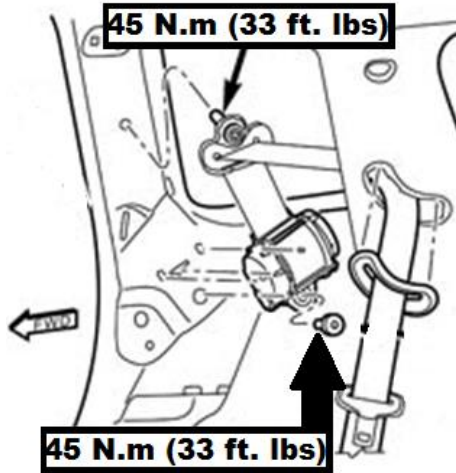

SEAT BELT RETRACTOR – REAR OUTBOARD

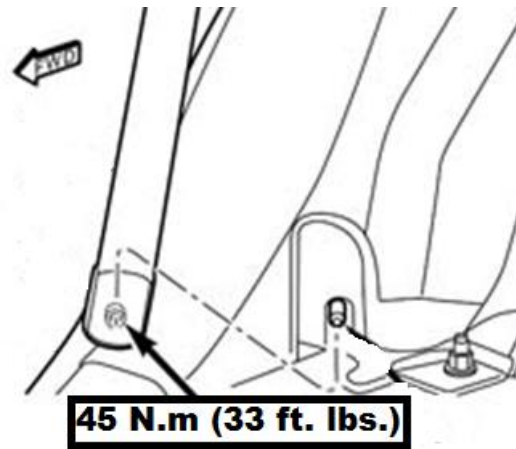

SEAT BELT RETRACTOR – REAR CENTER

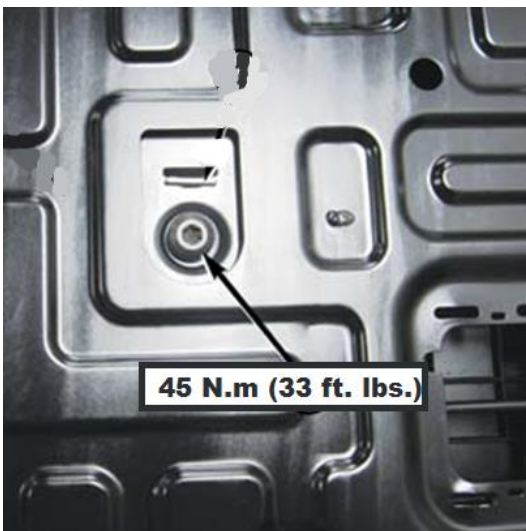

SEAT BELT RETRACTOR – REAR CENTER

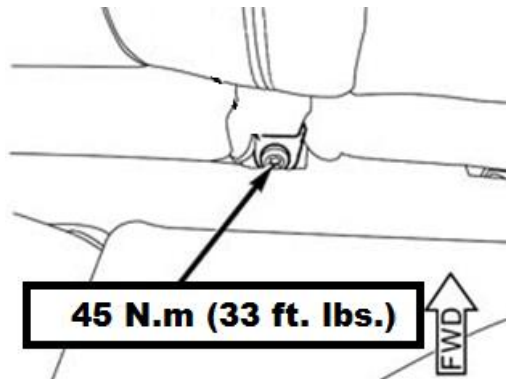

SEAT BELT TENSIONER – FRONT

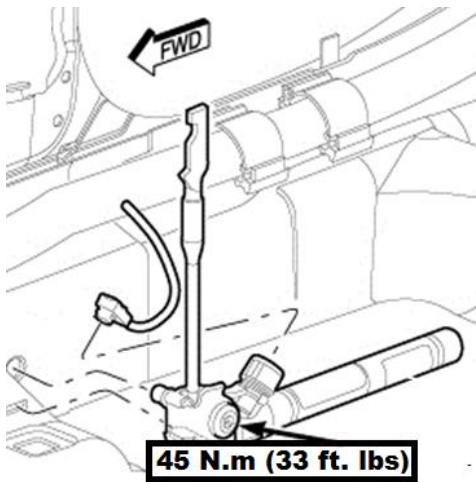

SEAT BELT BUCKLE – FRONT

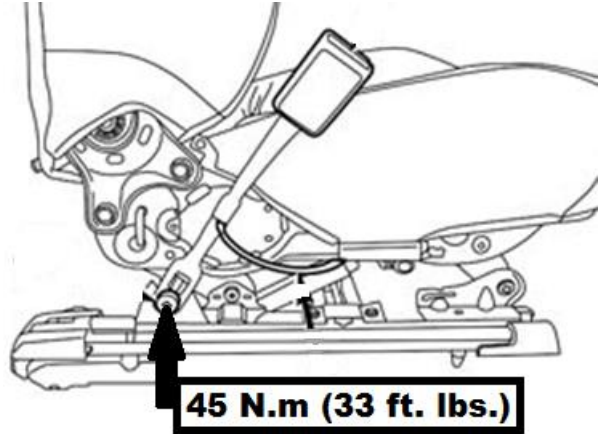

SEAT BELT BUCKLE – REAR LEFT

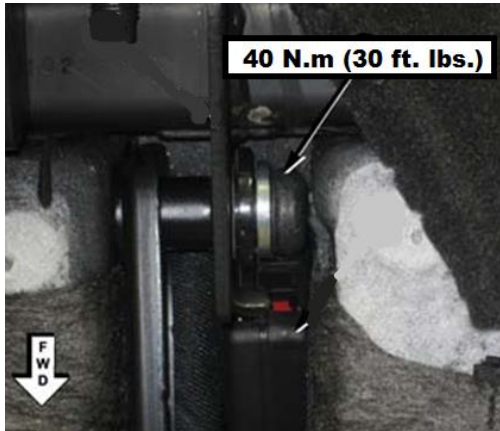

SEAT BELT BUCKLE – REAR RIGHT

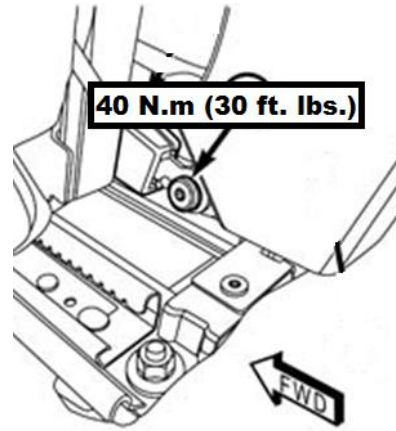

SEAT BELT BUCKLE – REAR CENTER

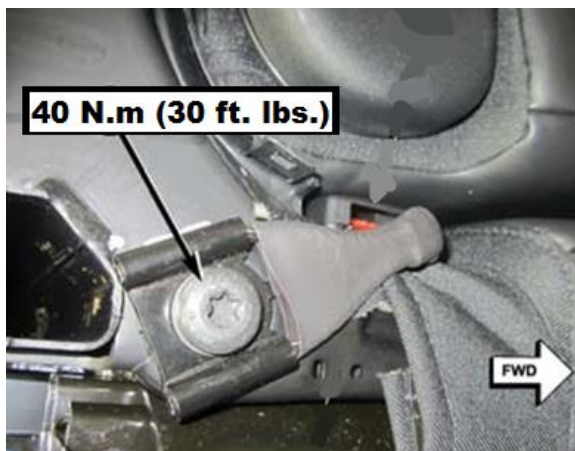

SEAT BELT INSTALLATION SHEET K6855946

FOR USE IN DODGE DART (PF) VEHICLES

WARNING: To avoid serious or fatal injury on vehicles equipped with airbags, disable the Supplemental Restraint System (SRS) before attempting any steering wheel, steering column, airbag, Occupant Classification System (OCS), seat belt tensioner, impact sensor or instrument panel component diagnosis or service. Disconnect and isolate the battery negative (ground) cable, then wait two minutes for the system capacitor to discharge before performing further diagnosis or service. This is the only sure way to disable the SRS. Failure to follow these instructions may result in accidental airbag deployment.

WARNING: To avoid serious or fatal injury during and following any seat belt or child restraint anchor service, carefully inspect all seat belts, buckles, mounting hardware, retractors, tether straps, and anchors for proper installation, operation, or damage. Replace any belt that is cut, frayed, or torn. Straighten any belt that is twisted. Tighten any loose fasteners. Replace any belt that has a damaged or ineffective buckle or retractor. Replace any belt that has a bent or damaged latch plate or anchor plate. Replace any child restraint anchor or the unit to which the anchor is integral that has been bent or damaged. Never attempt to repair a seat belt or child restraint component. Always replace damaged or ineffective seat belt and child restraint components with the correct, new and unused replacement parts listed in the Chrysler Mopar® Parts Catalog. Failure to follow these instructions may result in possible serious or fatal injury.

WARNING: To avoid serious or fatal injury on vehicles equipped with the Occupant Classification System (OCS), do not modify the front passenger seat assembly or center floor console in any way. Do not use any prior year, subsequent year, secondary or aftermarket seat trim covers. At no time should any Supplemental Restraint System (SRS) or OCS component be modified or replaced with any part except those which are specified for the particular vehicle application in the Chrysler Mopar® Parts Catalog. Failure to observe these precautions could cause an OCS miscalibration condition, which may result in the passenger airbag failing to deploy when required or deploying when not required.

WARNING: To avoid serious or fatal injury, never strike or drop a seat weight sensor or the passenger side front seat assembly to which the sensors are secured as it can damage the sensors or affect their calibration. The seat weight sensors and the passenger side front seat assembly must be handled with care to avoid damage to the sensors. Do not sit upon or place any loads upon a passenger side front seat while it is removed from its mounts in or outside of the vehicle. If an individual sensor is dropped or damaged, replace the sensor with a new and unused unit. If a seat has been dropped during removal or loaded while removed from its mounts, replace each of the seat weight sensors with new and unused units. Failure to observe this warning could result in an accidental, incomplete, or improper passenger side front Supplemental Restraint System (SRS) component deployment.

WARNING: To avoid serious or fatal injury on vehicles equipped with the Occupant Classification System (OCS), any time the passenger side front seat assembly has been removed or loosened from the vehicle for service of any vehicle component or system the Occupant Classification System (OCS) Verification Test must be performed using a diagnostic scan tool and the Occupant Classification Seat Weight special tool following reinstallation. Refer to the appropriate diagnostic procedures. Failure to observe this warning could result in an accidental, incomplete, or improper passenger side front Supplemental Restraint System (SRS) component deployment.

1. Identify the illustration which best represents the replacement seat belt assembly contained in this package.
2. Remove any interior trim parts, remove or reposition seats, as necessary, to allow removal of the seat belt assembly.
For additional information, refer to the vehicle service manual.
3. Install the replacement seat belt assembly, taking care to route the belt through openings in the interior trim parts as necessary.
4. Tighten the seat belt assembly anchor bolts to the torque specified in each seat belt assembly graphic.
5. After seat belt installation, reinstall the interior trim parts and/or seats. **For additional information, refer to the vehicle service manual.**
6. Place this Installation Instruction in the vehicle glove box.

RETRACTOR – FRONT

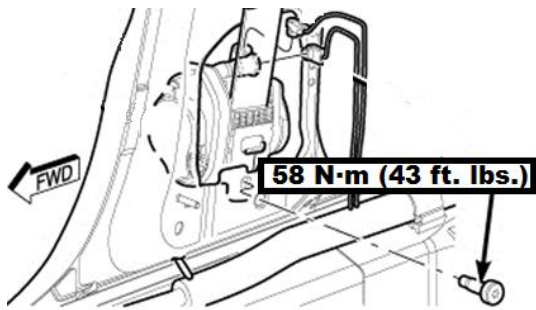

RETRACTOR – FRONT

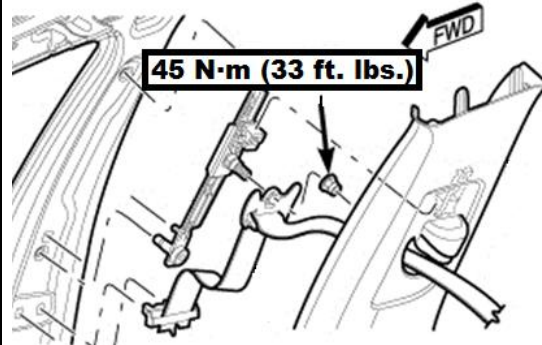

RETRACTOR – REAR CENTER

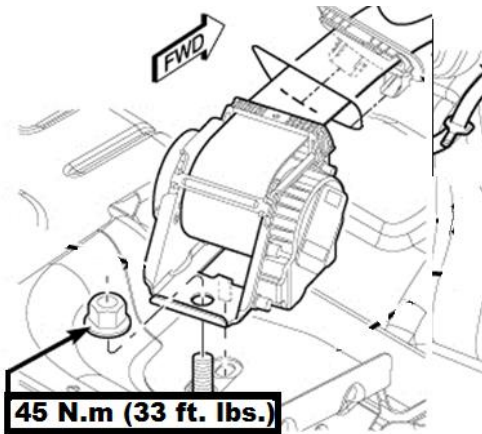

RETRACTOR – REAR CENTER

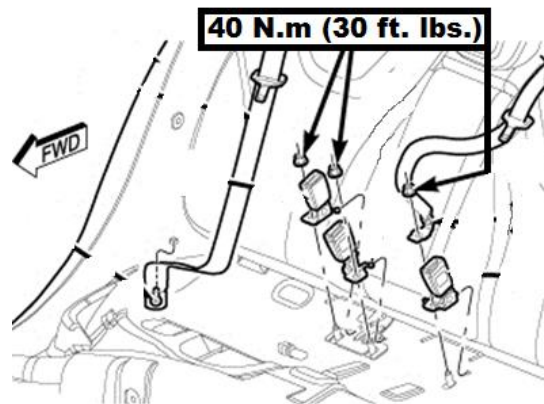

RETRACTOR – REAR OUTBOARD

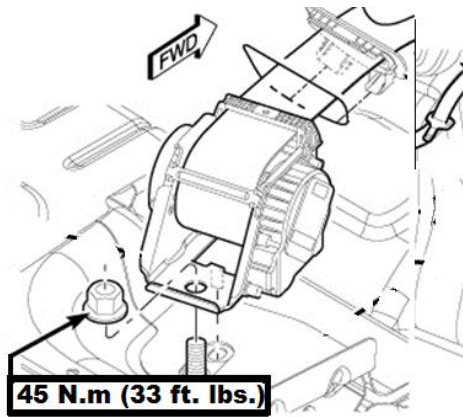

RETRACTOR – REAR OUTBOARD

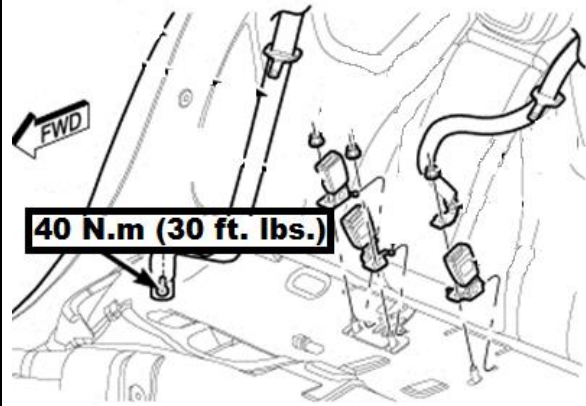

ANCHOR TENSIONER – FRONT

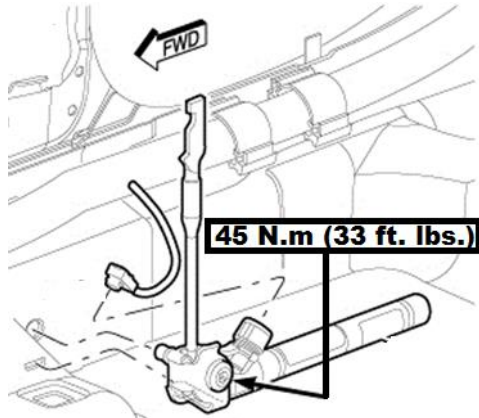

SEAT BELT BUCKLE – FRONT

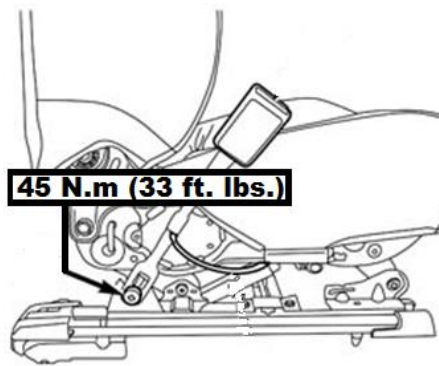

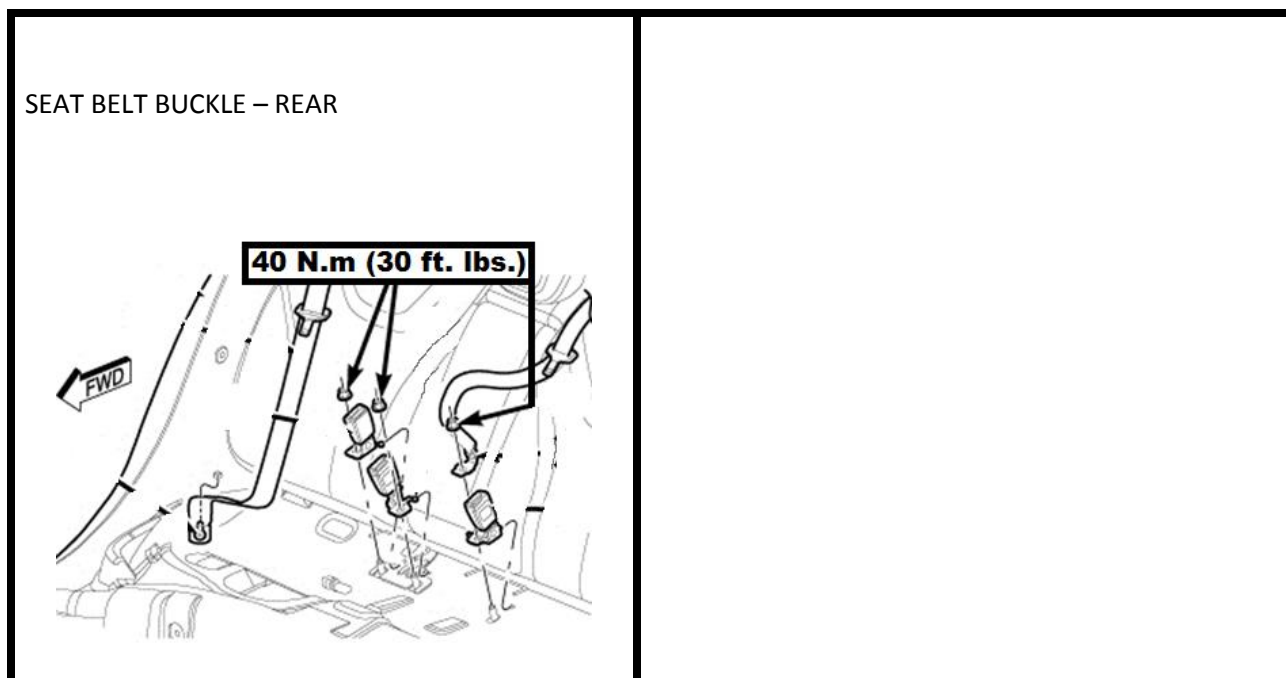

SEAT BELT INSTALLATION SHEET K6855941

FOR USE IN CHRYSLER 200 (UF) VEHICLES

WARNING: To avoid serious or fatal injury on vehicles equipped with airbags, disable the Supplemental Restraint System (SRS) before attempting any steering wheel, steering column, airbag, Occupant Classification System (OCS), seat belt tensioner, impact sensor or instrument panel component diagnosis or service. Disconnect and isolate the battery negative (ground) cable, then wait two minutes for the system capacitor to discharge before performing further diagnosis or service. This is the only sure way to disable the SRS. Failure to follow these instructions may result in accidental airbag deployment.

WARNING: To avoid serious or fatal injury during and following any seat belt or child restraint anchor service, carefully inspect all seat belts, buckles, mounting hardware, retractors, tether straps, and anchors for proper installation, operation, or damage. Replace any belt that is cut, frayed, or torn. Straighten any belt that is twisted. Tighten any loose fasteners. Replace any belt that has a damaged or ineffective buckle or retractor. Replace any belt that has a bent or damaged latch plate or anchor plate. Replace any child restraint anchor or the unit to which the anchor is integral that has been bent or damaged. Never attempt to repair a seat belt or child restraint component. Always replace damaged or ineffective seat belt and child restraint components with the correct, new and unused replacement parts listed in the Chrysler Mopar® Parts Catalog. Failure to follow these instructions may result in possible serious or fatal injury.

WARNING: To avoid serious or fatal injury on vehicles equipped with the Occupant Classification System (OCS), do not modify the front passenger seat assembly or center floor console in any way. Do not use any prior year, subsequent year, secondary or aftermarket seat trim covers. At no time should any Supplemental Restraint System (SRS) or OCS component be modified or replaced with any part except those which are specified for the particular vehicle application in the Chrysler Mopar® Parts Catalog. Failure to observe these precautions could cause an OCS miscalibration condition, which may result in the passenger airbag failing to deploy when required or deploying when not required.

WARNING: To avoid serious or fatal injury, never strike or drop a seat weight sensor or the passenger side front seat assembly to which the sensors are secured as it can damage the sensors or affect their calibration. The seat weight sensors and the passenger side front seat assembly must be handled with care to avoid damage to the sensors. Do not sit upon or place any loads upon a passenger side front seat while it is removed from its mounts in or outside of the vehicle. If an individual sensor is dropped or damaged, replace the sensor with a new and unused unit. If a seat has been dropped during removal or loaded while removed from its mounts, replace each of the seat weight sensors with new and unused units. Failure to observe this warning could result in an accidental, incomplete, or improper passenger side front Supplemental Restraint System (SRS) component deployment.

WARNING: To avoid serious or fatal injury on vehicles equipped with the Occupant Classification System (OCS), any time the passenger side front seat assembly has been removed or loosened from the vehicle for service of any vehicle component or system the Occupant Classification System (OCS) Verification Test must be performed using a diagnostic scan tool and the Occupant Classification Seat Weight special tool following reinstallation. Refer to the appropriate diagnostic procedures. Failure to observe this warning could result in an accidental, incomplete, or improper passenger side front Supplemental Restraint System (SRS) component deployment.

1. Identify the illustration which best represents the replacement seat belt assembly contained in this package.
2. Remove any interior trim parts, remove or reposition seats, as necessary, to allow removal of the seat belt assembly.
For additional information, refer to the vehicle service manual.
3. Install the replacement seat belt assembly, taking care to route the belt through openings in the interior trim parts as necessary.
4. Tighten the seat belt assembly anchor bolts to the torque specified in each seat belt assembly graphic.
5. After seat belt installation, reinstall the interior trim parts and/or seats. **For additional information, refer to the vehicle service manual.**
6. Place this Installation Instruction in the vehicle glove box.

RETRACTOR – FRONT

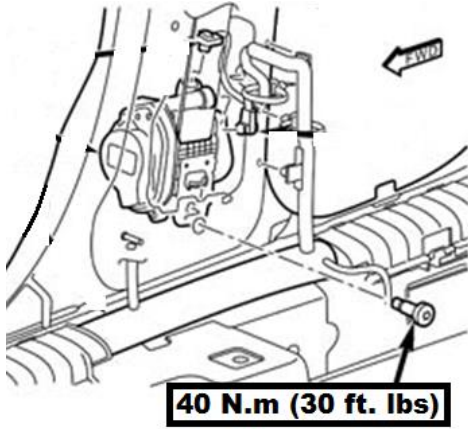

RETRACTOR – FRONT

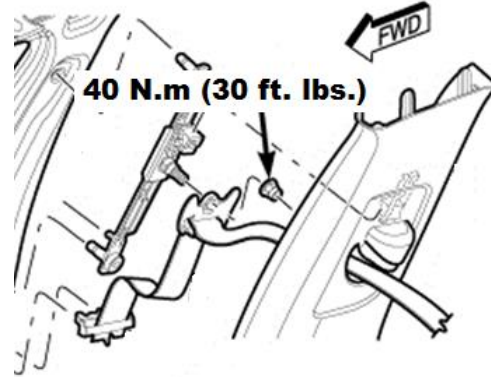

RETRACTOR – REAR CENTER

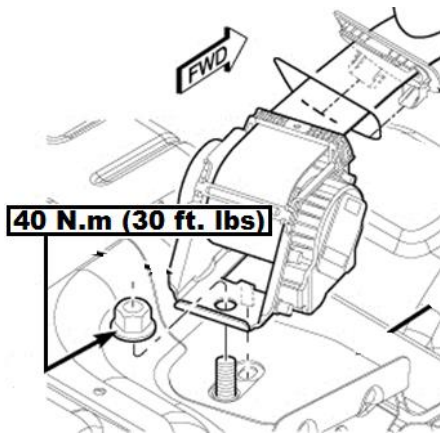

RETRACTOR – REAR CENTER

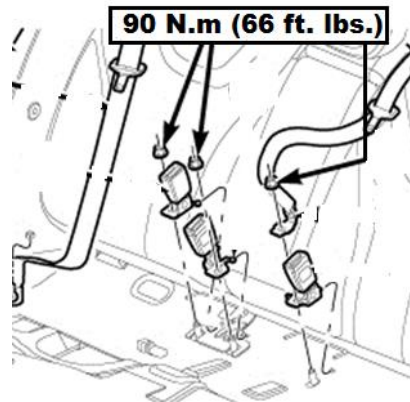

RETRACTOR – REAR OUTBOARD

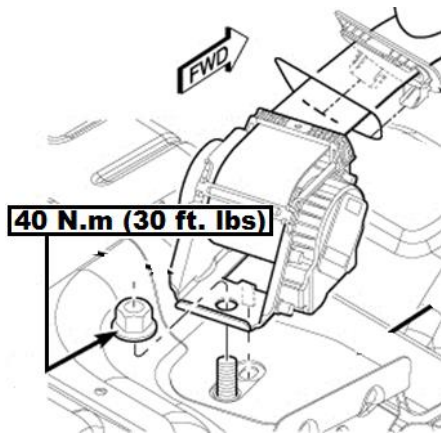

RETRACTOR – REAR OUTBOARD

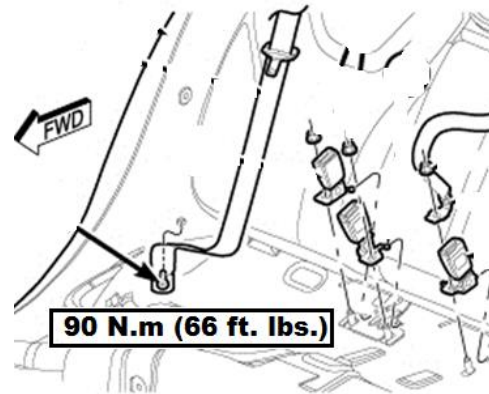

ANCHOR TENSIONER – FRONT

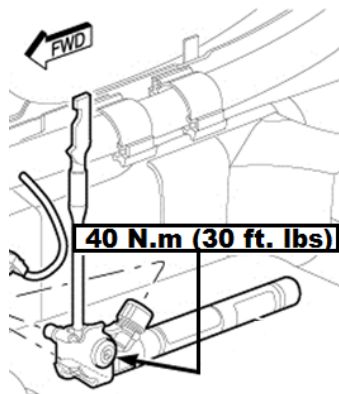

SEAT BELT BUCKLE – FRONT

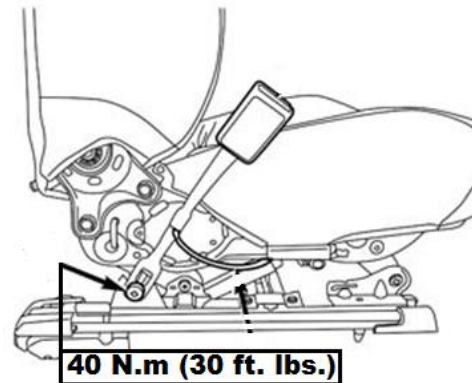

SEAT BELT BUCKLE – REAR

