

3.3L, 3.8L ENGINE

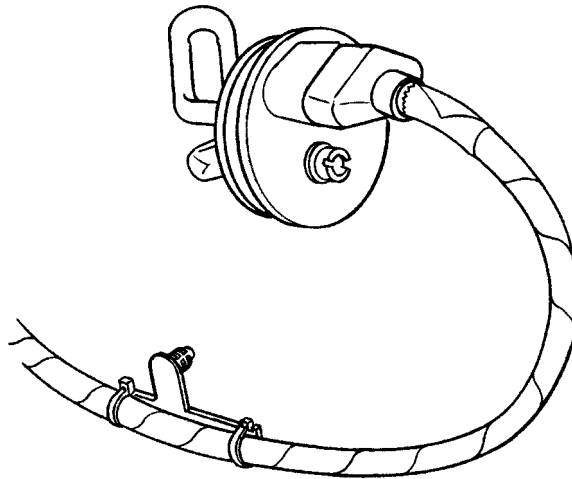

2.4L ENGINE

INSTALLATION INSTRUCTION ENGINE BLOCK HEATER

Subject to alteration without notice

09-28-00

K6858362

Expert Fitment Required

DAIMLERCHRYSLER

KIT CONTENTS FOR VEHICLES EQUIPPED WITH 3.3L OR 3.8L ENGINES. REFER TO PAGES 2-4.

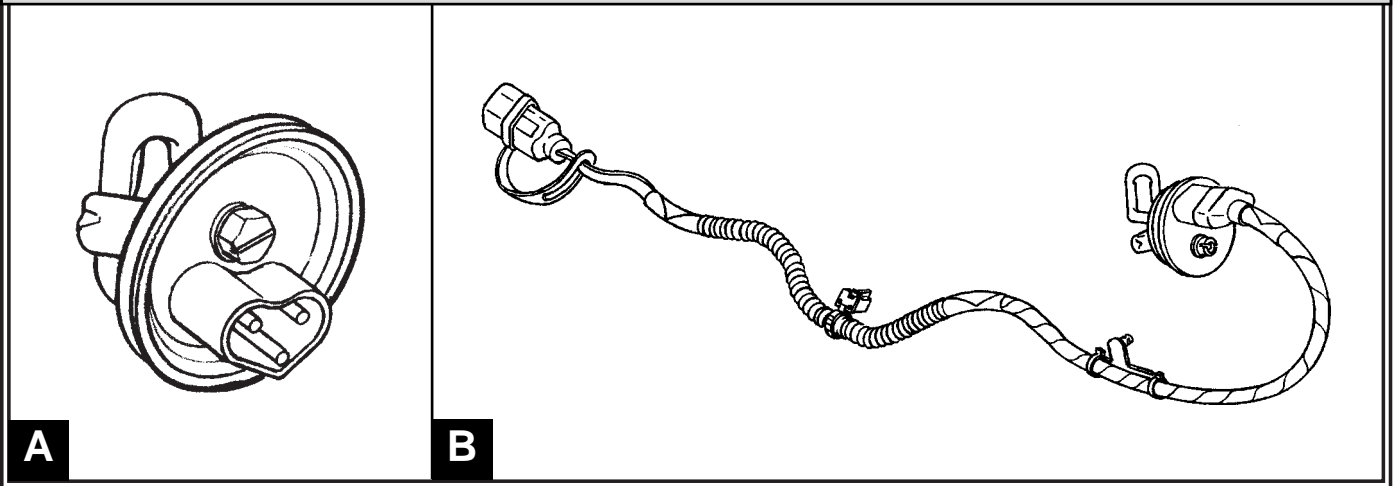

KIT CONTENTS FOR VEHICLES EQUIPPED WITH 2.4L ENGINES. REFER TO PAGES 2, 5-6.

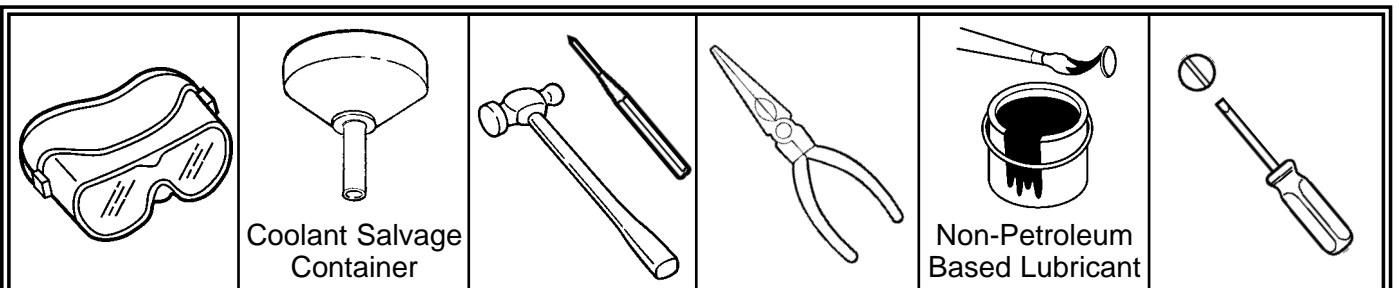
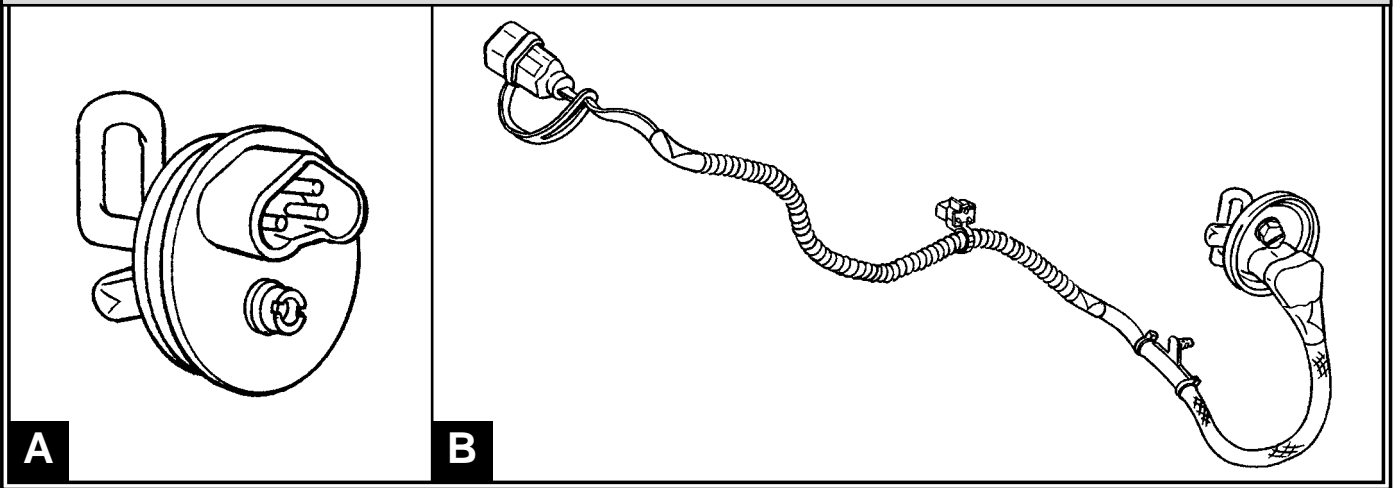

APPLICATION: MINIVAN (RS)

CAUTION! Before connecting the block heater/cordset to a power source, be sure that the element is immersed in coolant. NEVER energize heater in the open air. The element sheath could burst.

- Disconnect and isolate the negative battery cable.
- Drain coolant from the radiator and cylinder block and save for re-use. Refer to cooling system draining procedure in the service manual.

CAUTION! Make sure that vehicle has completely cooled off before starting the install.

- Raise and secure the vehicle on a lift.

3.3L OR 3.8L ENGINE BLOCK HEATER INSTALL:

- Locate engine block core plug under the exhaust manifold and on the transmission side of engine.

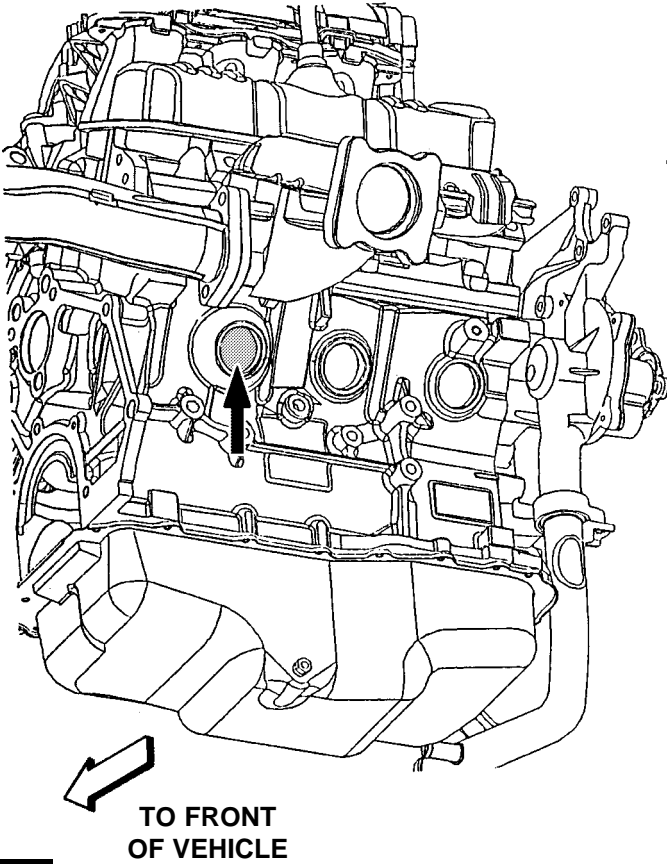

- Using a center punch and hammer, carefully strike the bottom edge of the core plug to break it loose.

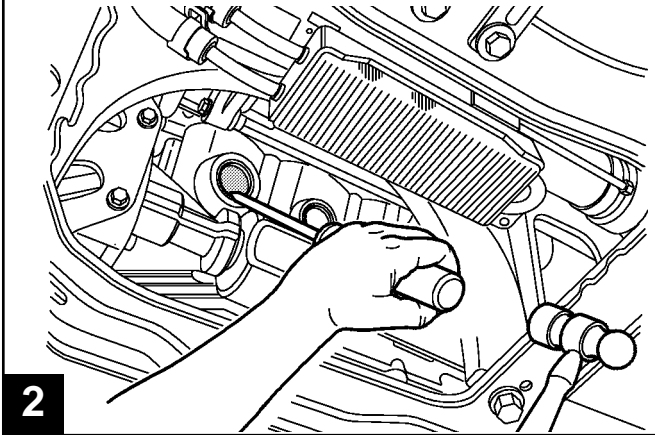

- Remove and discard the core plug.
- Clean the machined part of hole.

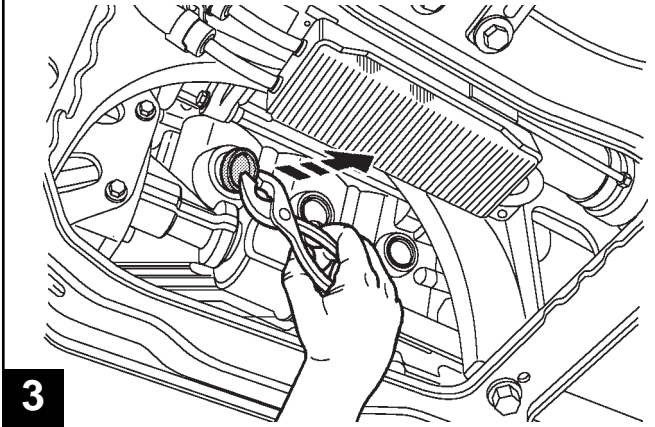

- Apply a coating of lubricant to the surface of hole and the "O" ring on the block heater.
- Insert block heater with element facing up. Push into block until fully seated.
- Using a flat blade screwdriver, tighten the center screw. (Do not overtighten.)

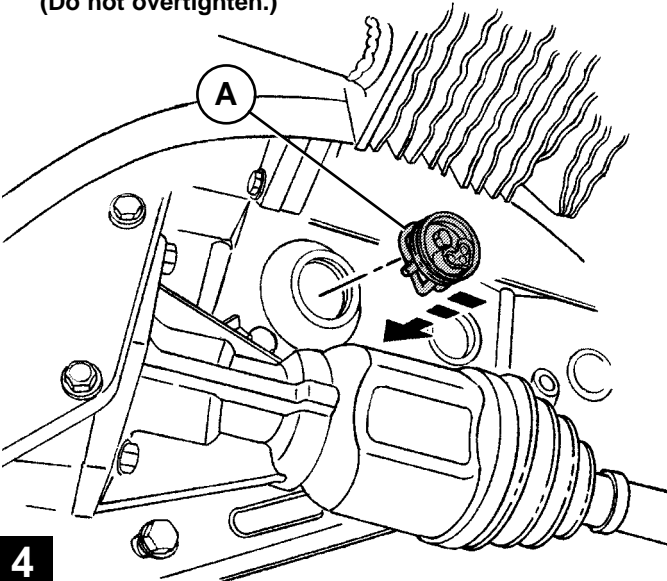

- Plug the cordset firmly into the block heater.

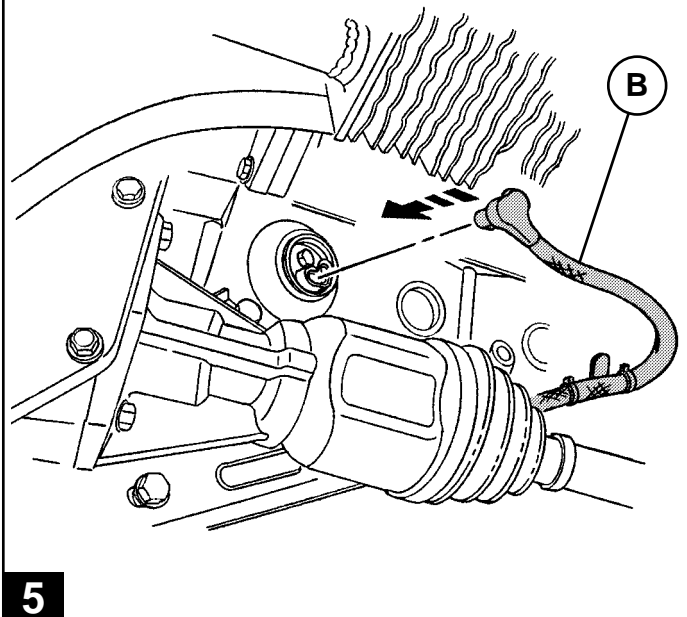

3.3L OR 3.8L ENGINE BLOCK HEATER INSTALL:

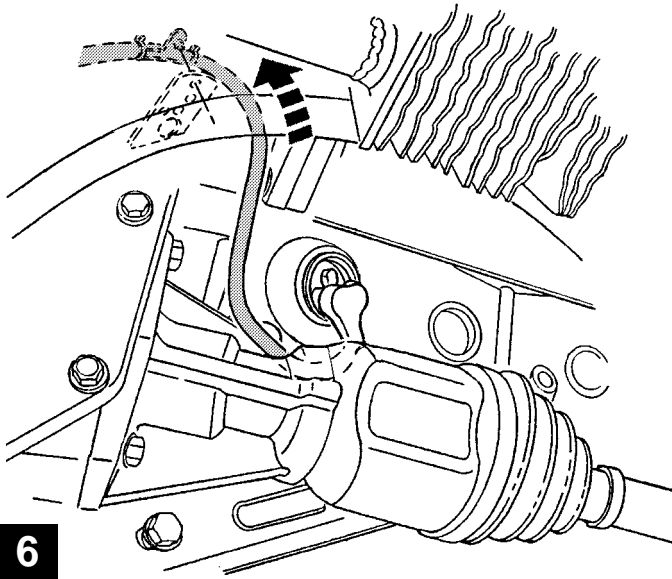

- Route cordset up over the left rear engine mount. Insert the in-line T-clip into top hole of harness mounting bracket.

CAUTION! Make sure that cordset is positioned away from the exhaust manifold.

- Continue to route cordset upwards along the left side of engine.
- Lower the vehicle and open the hood.

6

- Route cordset around the back of the battery and power distribution center.
- Attach the in-line receptacle onto existing body harness stud as shown.

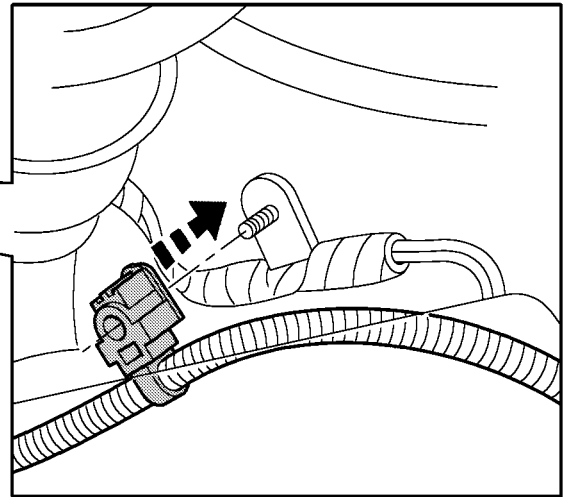
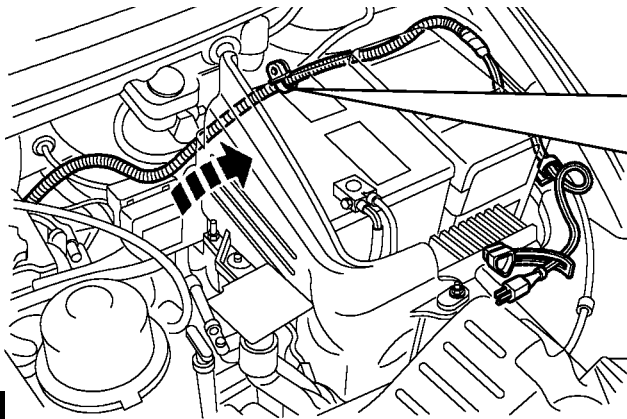

7

- Position cordset plug close to the upper radiator support.
- Refill cooling system with the retained coolant.
- Re-connect the negative battery cable.
- Start the engine and check for leaks at the block heater.

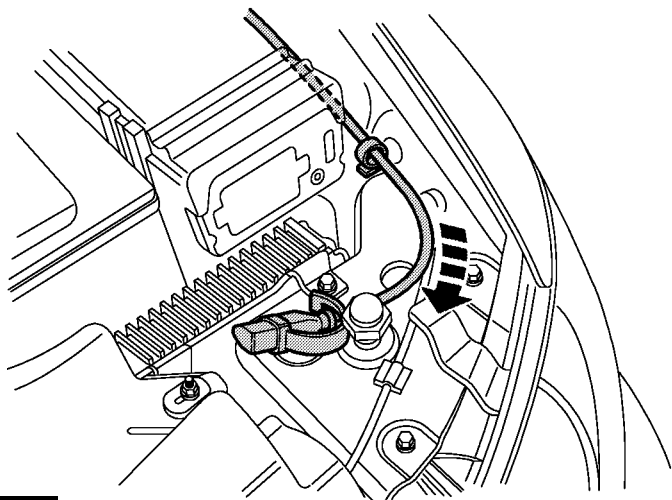

8

2.4L ENGINE BLOCK HEATER INSTALL:

- Locate engine block core plug under the exhaust manifold and on the drive belt side of engine.

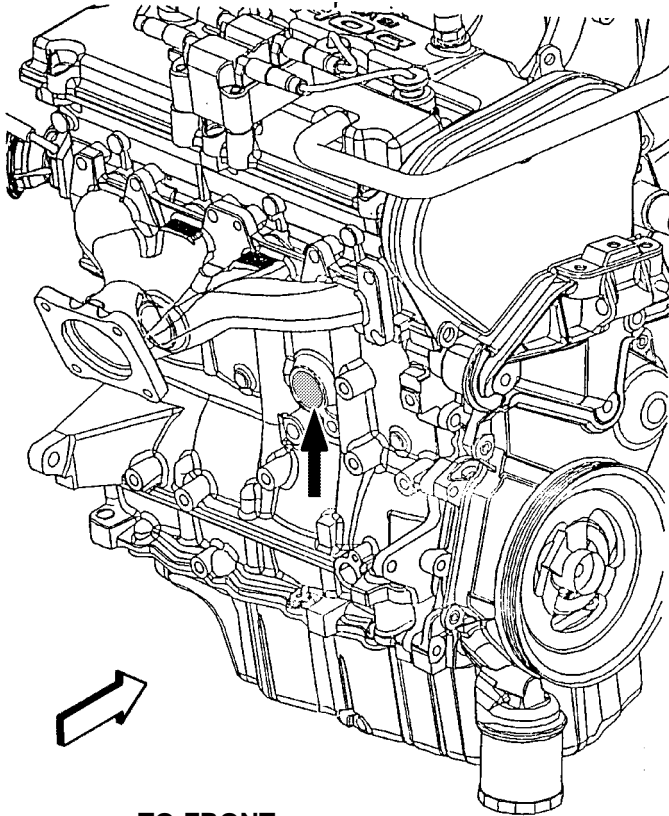

TO FRONT
OF VEHICLE

1

- Using a center punch and hammer, carefully strike the bottom edge of the core plug to break it loose.

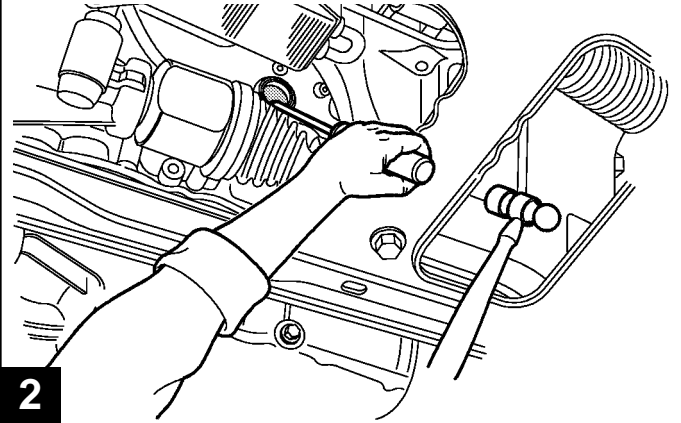

2

- Remove and discard the core plug.
- Clean the machined part of hole.

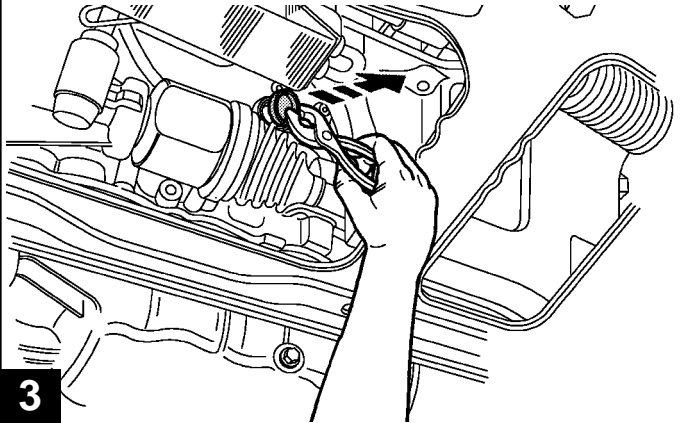

3

- Apply a coating of lubricant to the surface of hole and the "O" ring on the block heater
- Insert block heater with element facing up. Push into block until fully seated.
- Using a flat blade screwdriver, tighten the center screw. (Do not overtighten.)

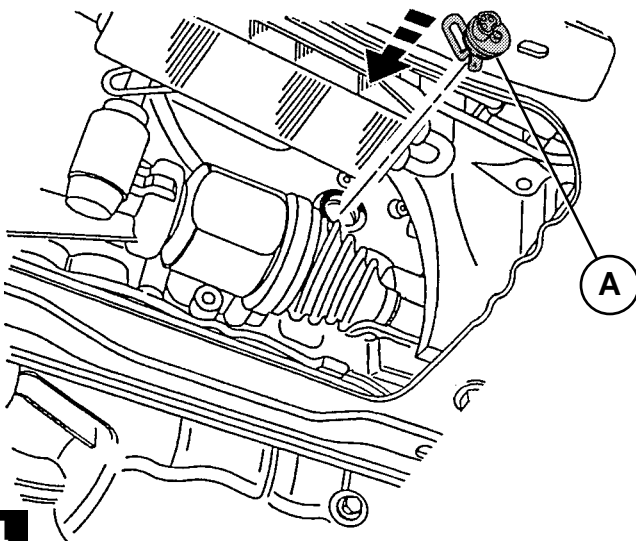

4

- Plug the cordset firmly into the block heater.

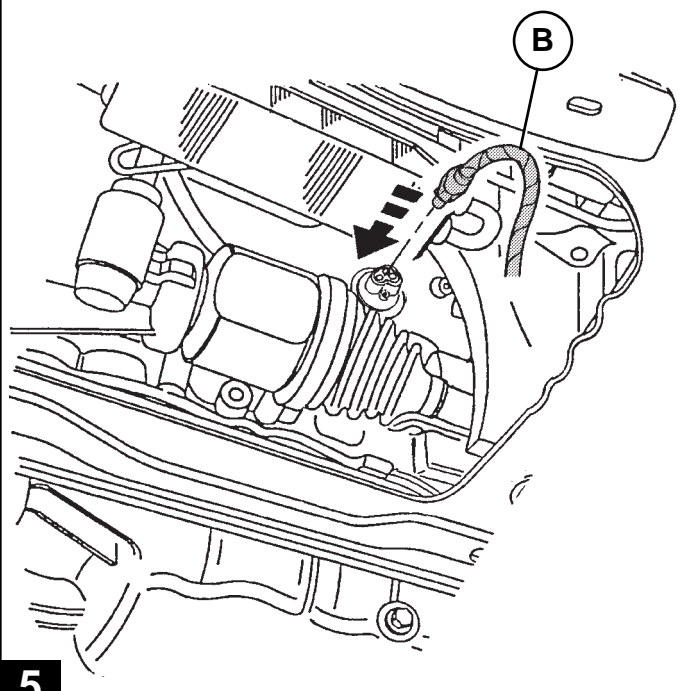

5

2.4L ENGINE BLOCK HEATER INSTALL:

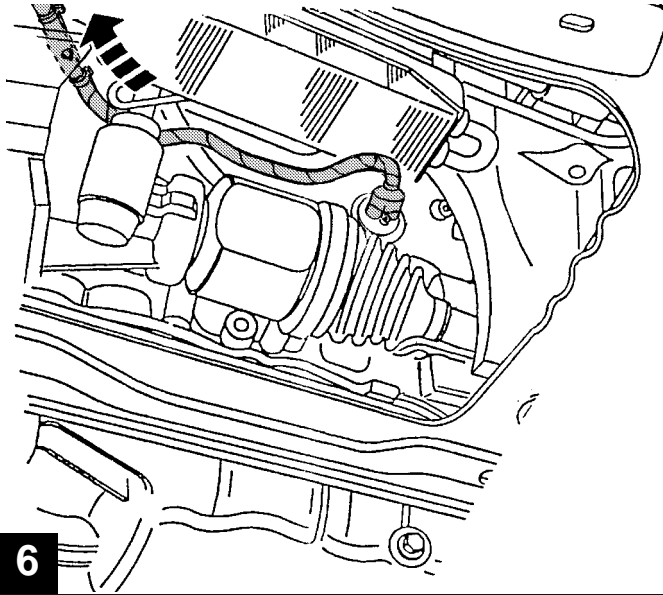

- Route cordset up over the left rear engine mount. Insert the in-line T-clip into top hole of harness mounting bracket.

CAUTION! Make sure that cordset is positioned away from the exhaust manifold.

- Continue to route cordset upwards along the left side of engine.
- Lower the vehicle and open the hood.

- Route cordset around the back of the battery and power distribution center.
- Attach the in-line receptacle onto existing body harness stud as shown.

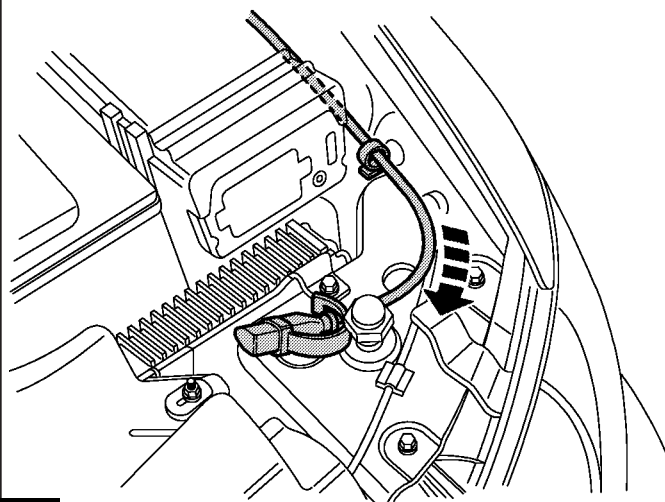
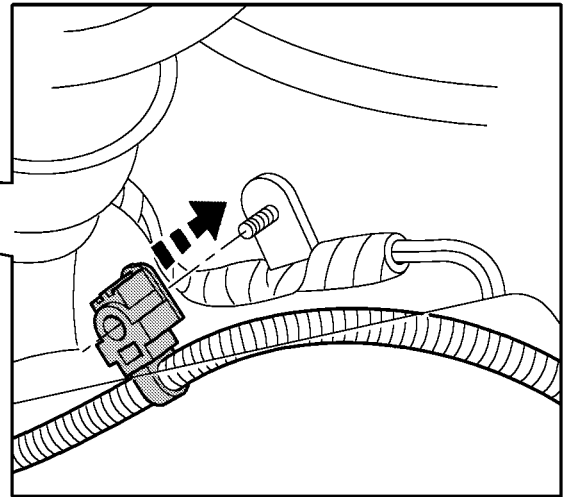
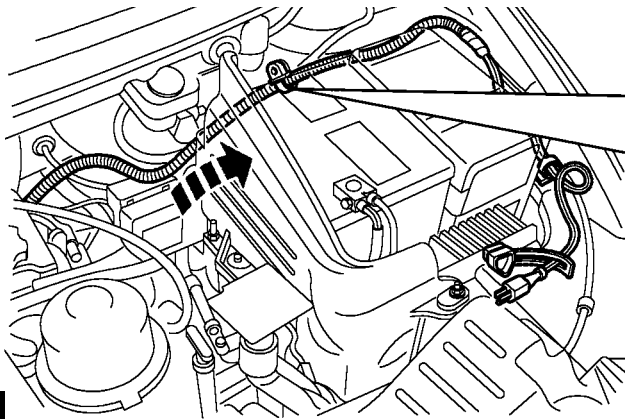

- Position cordset plug close to the upper radiator support.
- Refill cooling system with the retained coolant.
- Re-connect the negative battery cable.
- Start the engine and check for leaks at the block heater.