



# DVD REAR SEAT VIDEO SYSTEM

## CHRYSLER PACIFICA

MOPAR®

### INSTALLATION INSTRUCTIONS

*Read entire instructions thoroughly before starting.*

#### TOOLS REQUIRED:

- Non-metal trim stick
- Phillips screwdriver
- T20 Screwdriver
- Scissors
- Sharp utility knife
- New roll of masking tape
- Metal fish wire
- 8mm Deep well socket
- Socket wrench with long extension
- Foam Tape

#### CONTENTS:

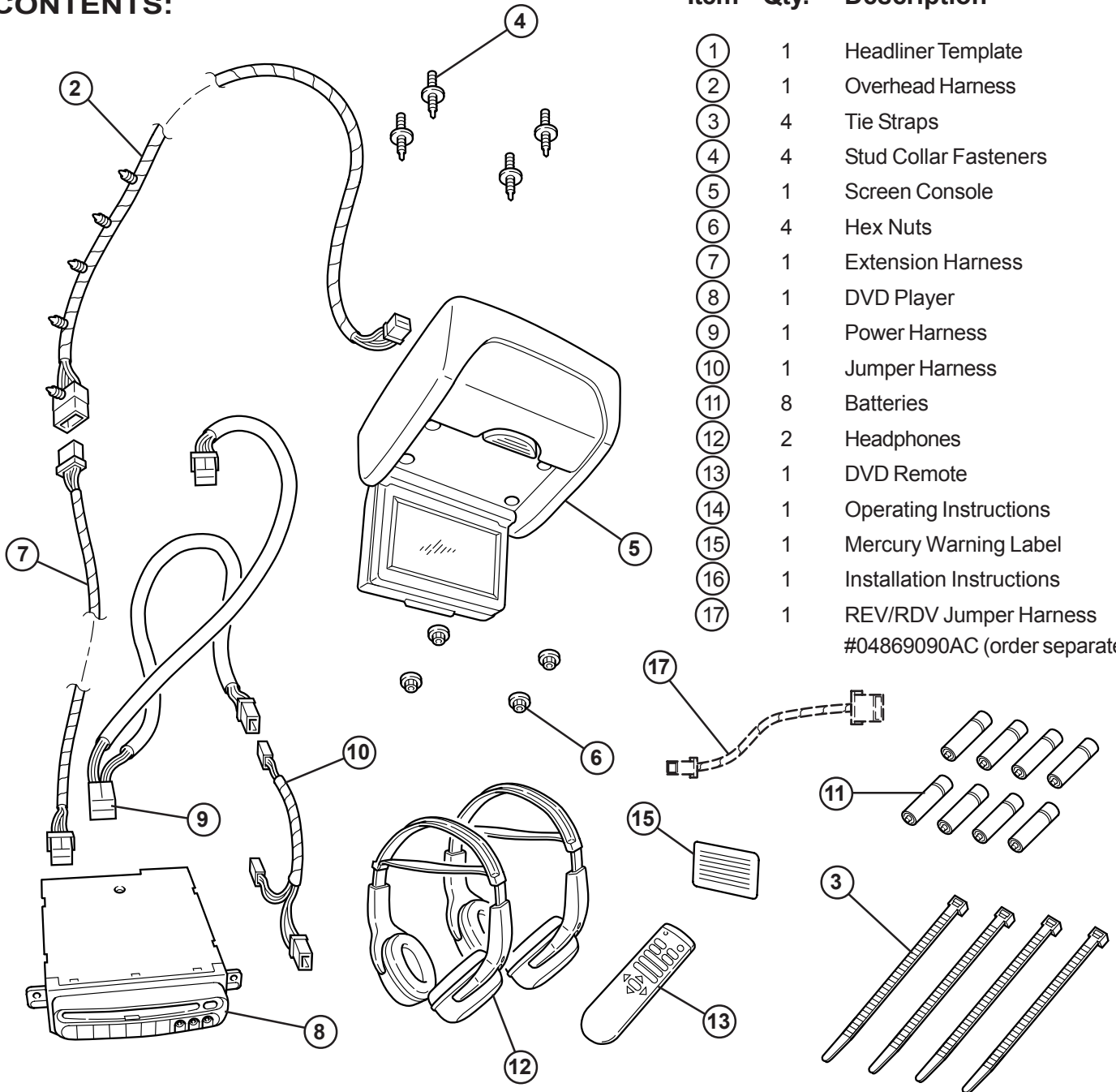

Item	Qty.	Description
①	1	Headliner Template
②	1	Overhead Harness
③	4	Tie Straps
④	4	Stud Collar Fasteners
⑤	1	Screen Console
⑥	4	Hex Nuts
⑦	1	Extension Harness
⑧	1	DVD Player
⑨	1	Power Harness
⑩	1	Jumper Harness
⑪	8	Batteries
⑫	2	Headphones
⑬	1	DVD Remote
⑭	1	Operating Instructions
⑮	1	Mercury Warning Label
⑯	1	Installation Instructions
⑰	1	REV/RDV Jumper Harness #04869090AC (order separately)

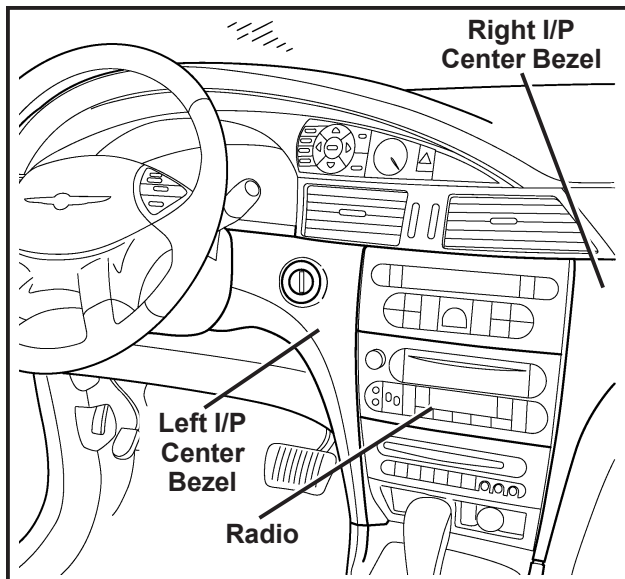

- 1) Disconnect and isolate negative battery cable.

### **A – Interior Trim Panel and Component Removal:**

- 2) Detach the center console shift bezel.
- 3) Remove ignition key bezel.
- 4) Remove left and right I/P center bezels using a non-metal trim stick.
- 5) Disconnect and remove the CD/DVD player or cubby bin (four phillips screws).
- 6) Disconnect and remove the radio (four phillips

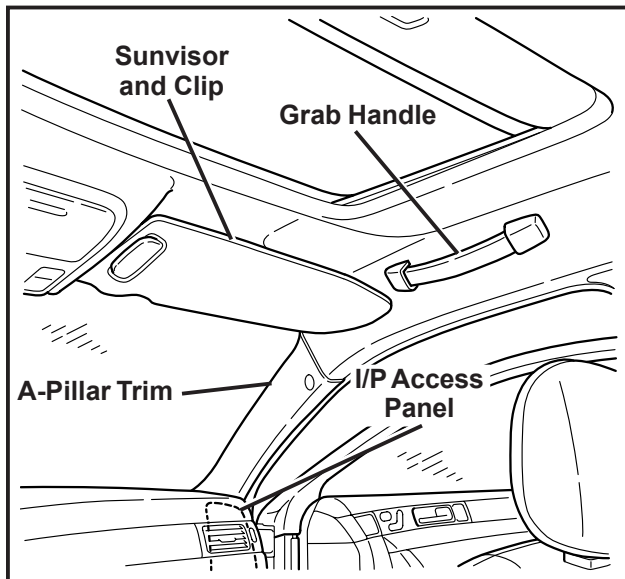

screws).

- 7) Remove right (passenger's side) A-pillar trim panel (one phillips screw).
- 8) Remove right side I/P access panel.
- 9) Disconnect and remove right sunvisor (two T20 screws).
- 10) Remove right sunvisor clip (one T20 screw).

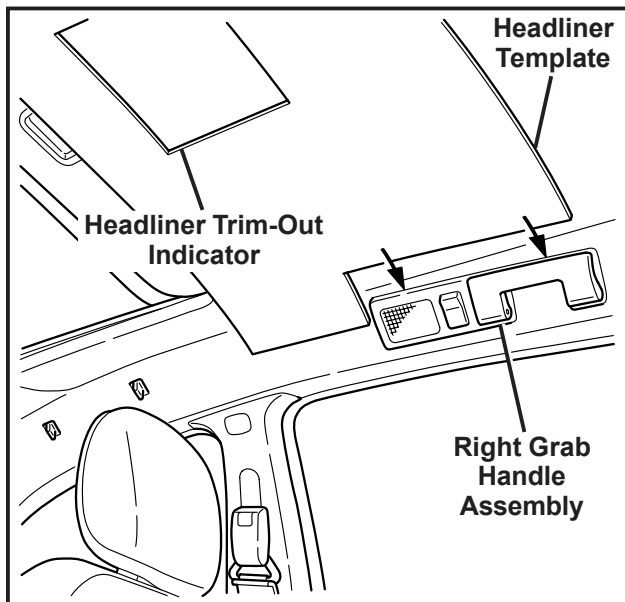

- 11) Remove right front headliner grab handle (two phillips screws).

### **B – Trim Out the Headliner:**

- 1) Trim out supplied template (Item 1) along the dotted lines.
- 2) Position template to the headliner, making sure that it aligns to the left and right grab handle assemblies.
- 3) Secure template to headliner where indicated using new masking tape.

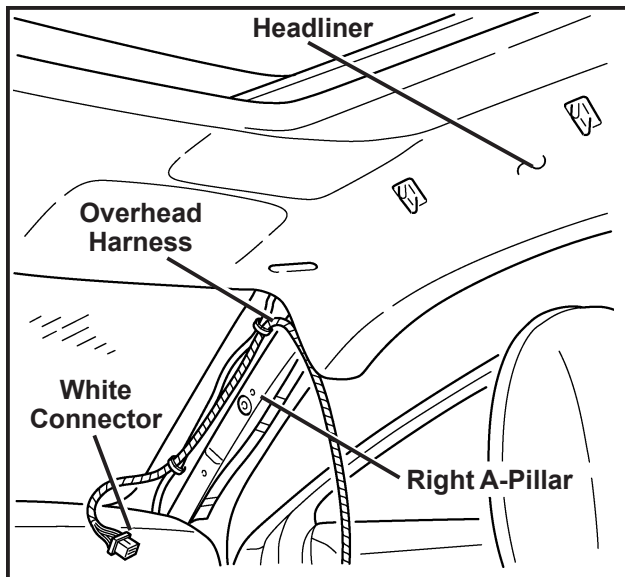

- 4) Trim out the headliner per template instructions using a sharp utility knife.

**C – Install Overhead Harness:**

- 1) Position overhead harness (Item 2) to the right A-pillar as shown. Secure it to the existing harness using two tie straps (Item 3).
- 2) Carefully pull headliner down just enough to allow the overhead harness to route rearward.

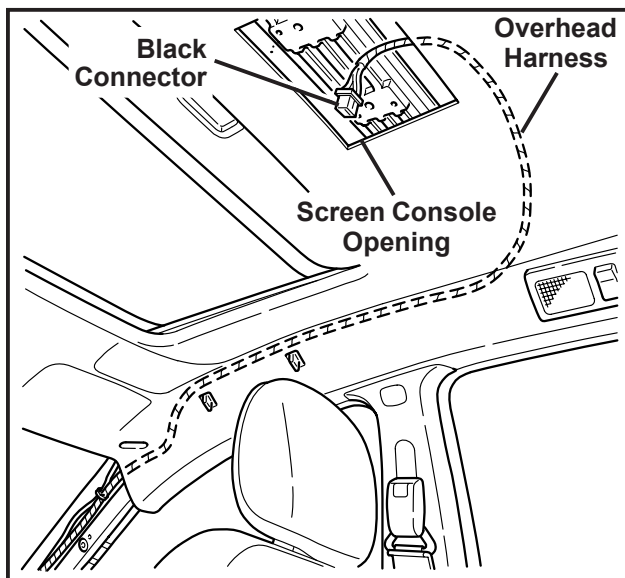

**CAUTION! Headliner is held in place with velcro strips. Take care that headliner does not crease.**

- 3) Route harness in-between the headliner and inner roof panel, keeping clear of the sunvisor and grab handle openings.

**CAUTION! Stay clear of airbag tether in the A-pillar and side curtain airbag in the headliner.**

- 4) Continue to route harness rearward then across to the screen console opening as shown.

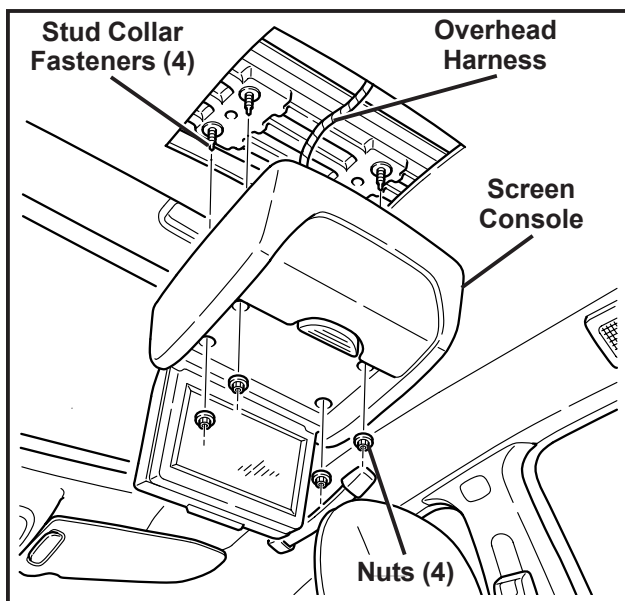

**NOTE: the use of a metal fish wire may be needed.**

- 5) Re-install sunvisor, clip, and grab handle.

**D – Install Screen Console:**

- 1) Using a #4 inverted torx driver, install four supplied stud collar fasteners (Item 4) to the inner roof crossmember.
- 2) Plug and lock overhead harness connector into the screen console (Item 5).

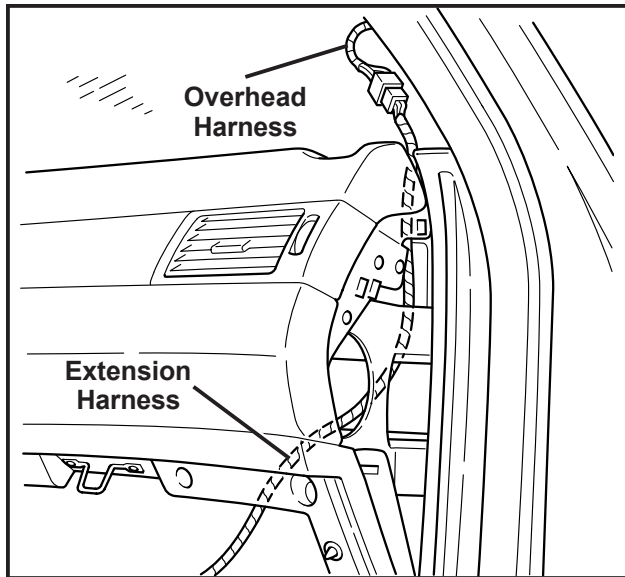

- 3) Install screen console with four supplied nuts (Item 6) using an 8mm deep well socket.

### ***E – Install Extension Harness:***

- 1) Hand feed black connector on extension harness (Item 7) down inside the I/P, keeping between the A-pillar and I/P top cover.

**NOTE:** Keep harness away from any sharp edges, heat sources, or moving parts.

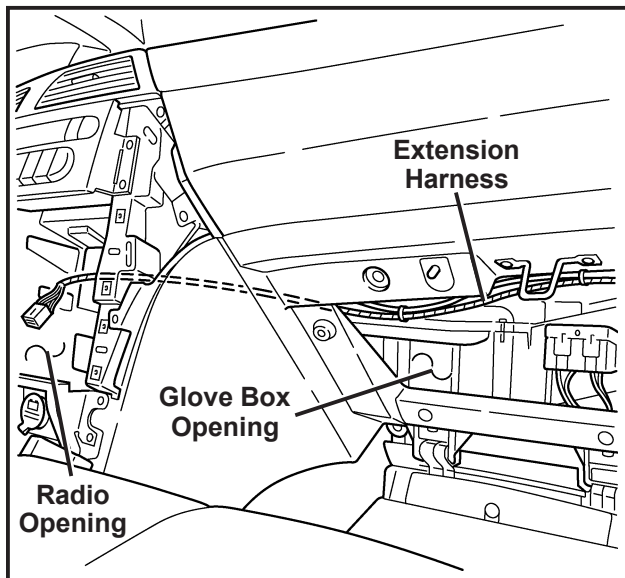

- 2) Plug white connector on extension harness into the overhead harness. Wrap this connection with foam tape to prevent rattles.
- 3) Route harness across the back of glove box opening and into the radio opening.
- 4) Secure harness to existing vehicle harness at the back of glove box using two tie straps.

**NOTE:** Installation of existing DVD—proceed to F1. Installation of new DVD—proceed to F2. Installation of new DVD/CD player with DVD/CD radio—proceed to F3

### ***F1 – Install DVD Player:***

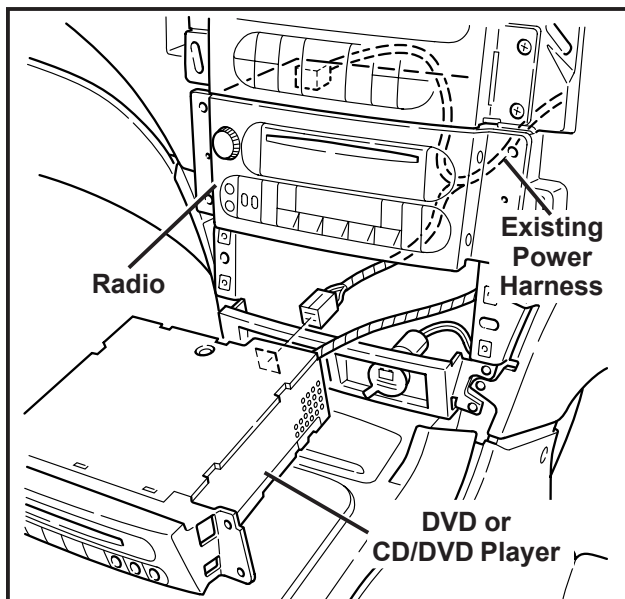

- 1) Plug 12-way extension harness connector into the existing DVD player.
- 2) Plug 16-way power harness connector into the existing DVD player.
- 3) Install DVD player using four previously removed phillips screws.
- 4) Plug 10-way power harness connector into the radio.
- 5) Re-connect and re-install the radio.
- 6) Proceed to Section G for operation test.

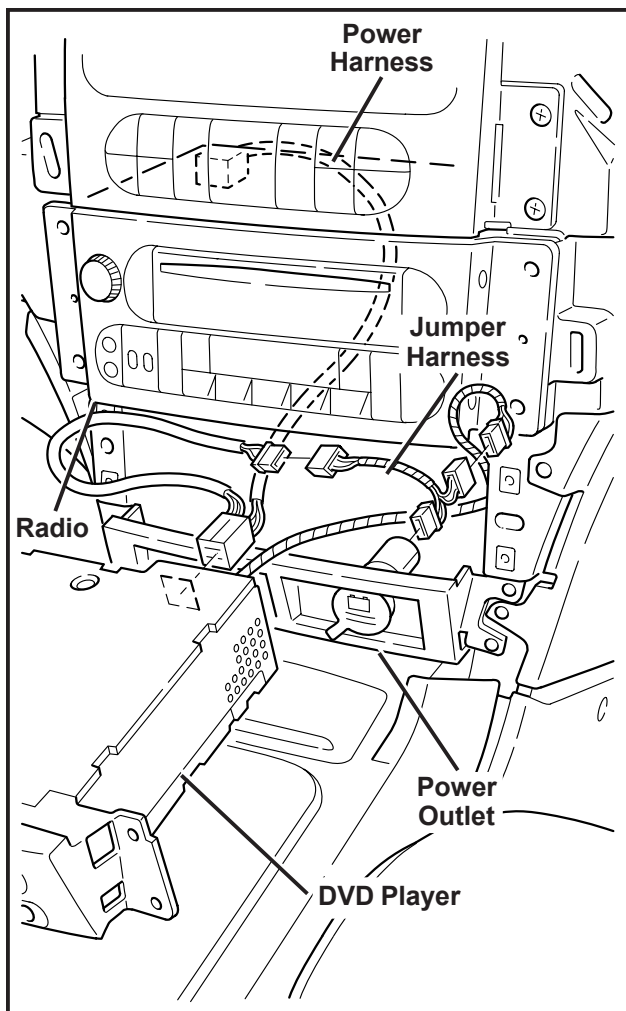

**NOTE:** Some vehicles may be equipped with an existing power harness. The supplied power harness (Item 9) and jumper harness (Item 10) will not be needed.

**F2 – Install New DVD Player:**

- 1) Plug 12-way extension harness connector into the existing DVD player (Item 8).
- 2) Plug in existing 10-way behind radio or use (Item 9).
- 3) Re-connect and re-install the radio.
- 4) Plug in existing 16-way behind DVD player or use (Item 9).

**NOTE:** If using existing power harness—skip to Step 7.

- 5) Plug 2-way power harness connector into supplied jumper harness (Item 10).
- 6) Disconnect right (passenger's side) power outlet. Plug 2-way jumper harness connectors in-between.
- 7) Install DVD player using four previously removed phillips screws.

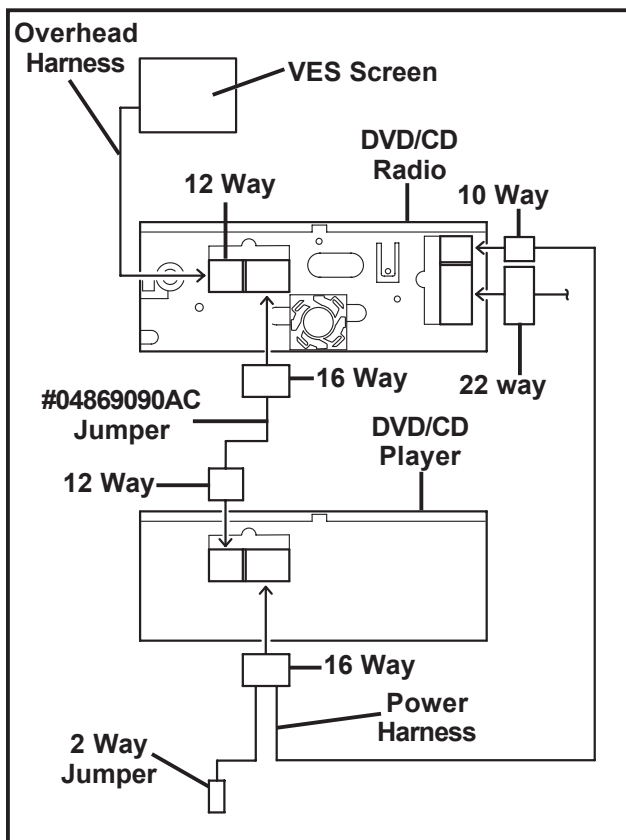

**F3 – Install New DVD/CD Player With DVD/CD Radio:**

- 1) Plug 12-way extension harness connector into the DVD/CD Radio.
- 2) Plug in existing 10-way behind DVD/CD Radio or use (Item 9).
- 3) Plug in 16-way (Item 9) behind DVD/CD Player.
- 4) Plug in existing 22-way behind DVD/CD Radio.
- 5) Plug in 16-way (Item 17, 04869090AC) behind DVD/CD Radio.
- 6) Plug in 12-way (Item 17, 04869090AC, order separately) behind DVD/CD Player.
- 7) connect and install the DVD/CD Radio and Player.
- 8) Proceed to Section G for operation test.

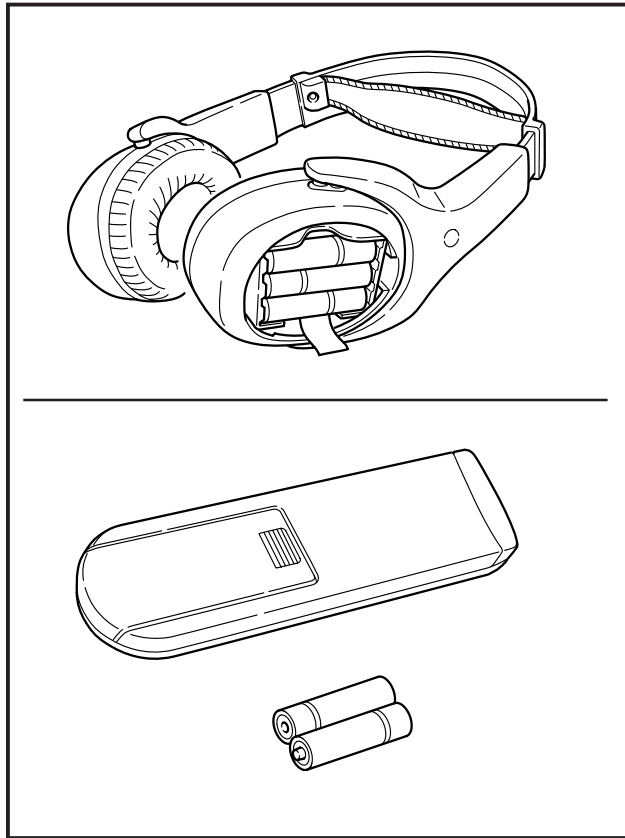

### **G– Operation Test:**

- 1) Re-connect the vehicle's battery.
- 2) Place supplied batteries (Item 11) into both headphones (Item 12) and DVD remote (Item 13).
- 3) Slowly remove plastic cover from the display screen.
- 4) Turn on ignition, unit will power up. Insert a known good DVD.
- 5) Verify function of headphones and DVD remote using supplied Operating Instructions (Item 14).
- 6) Place Operating Instructions in the vehicle's glove box.
- 7) Refer to vehicle Owner's Manual for headphone and video instructions.

**NOTE: Peel and stick mercury warning label (Item 15) to lower portion of forward facing surface on the left (driver's side) B-pillar.**