

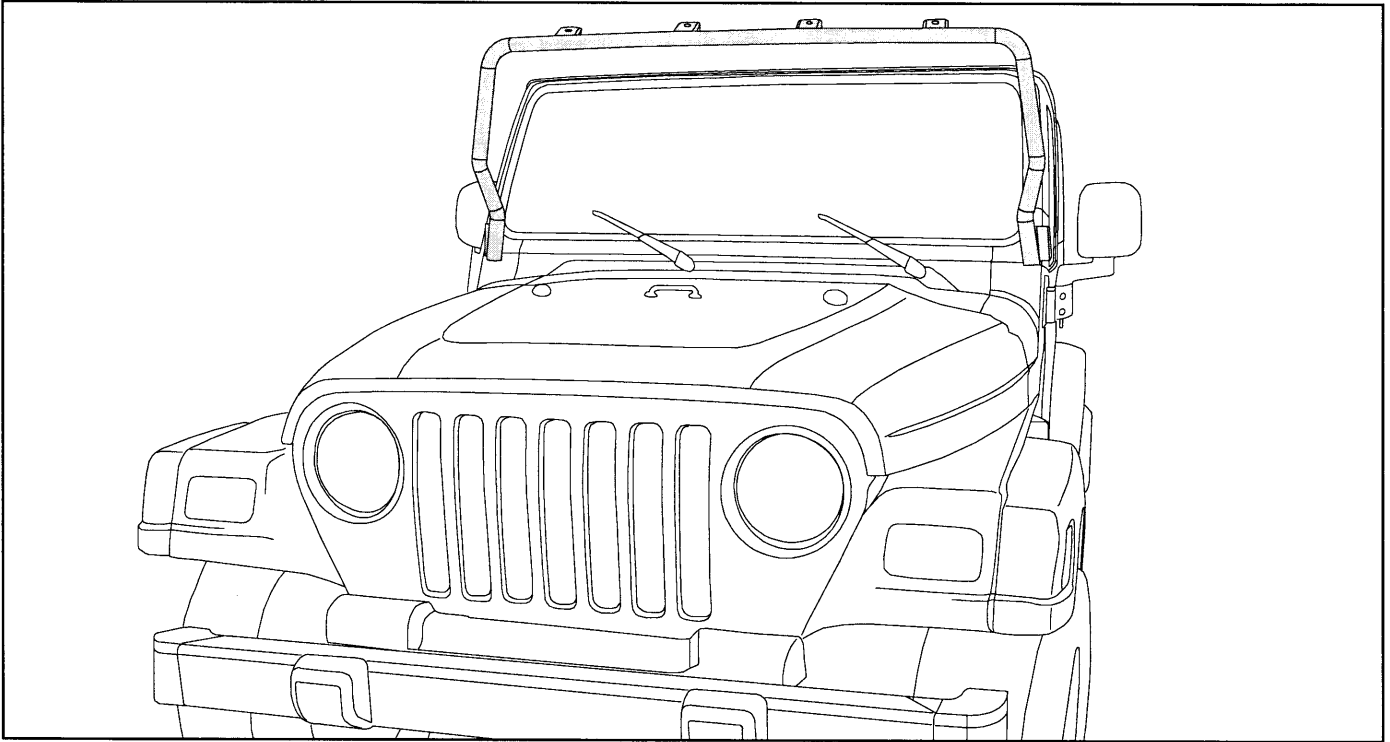

**NOTE: DO NOT INSTALL THIS PRODUCT  
ON LONG WHEEL BASE SOFT TOP  
WRANGLERS.**



**GB** *INSTALLATION INSTRUCTIONS LIGHT BAR*

**E** *INSTRUCCIONES DE MONTAJE BARRA DE LUMIERE*

**F** *NOTICE DE MONTAGE BARRA DE LUZ*

Subject to alteration without notice.

Reservadas modificaciones técnicas.

Sous reserve de modifications techniques.

20-09-2004  
K6859469  
©DAILERCHRYSLER



**NOTE: DO NOT INSTALL THIS PRODUCT ON LONG WHEEL BASE SOFT TOP WRANGLERS.**

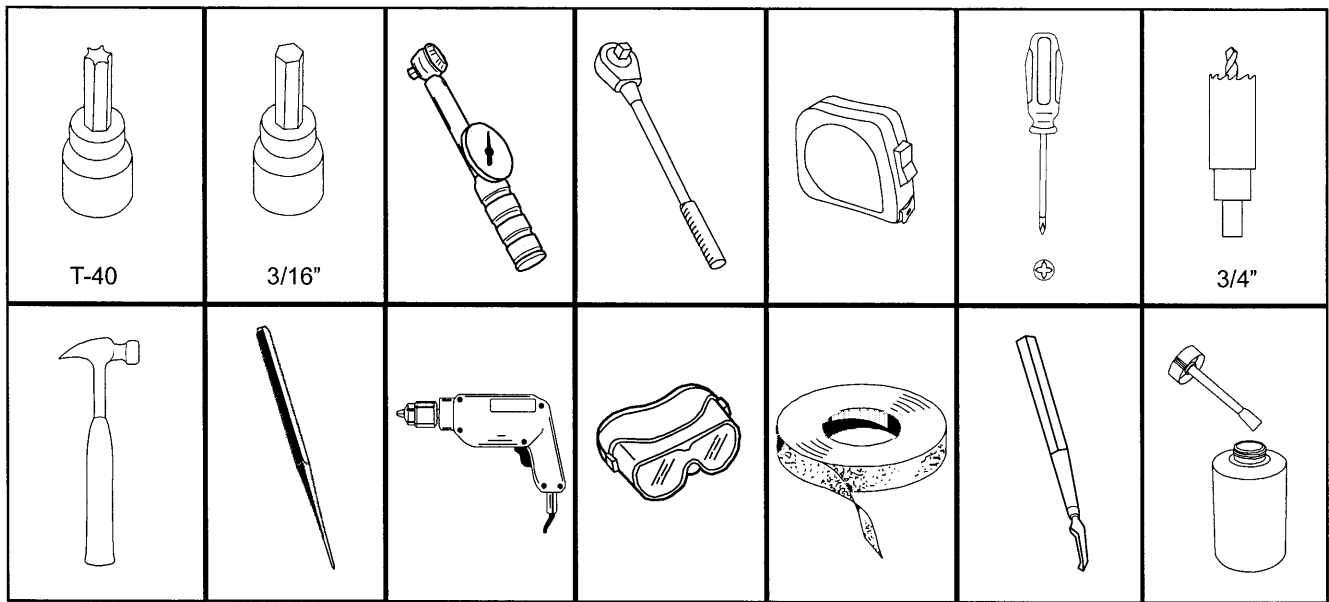
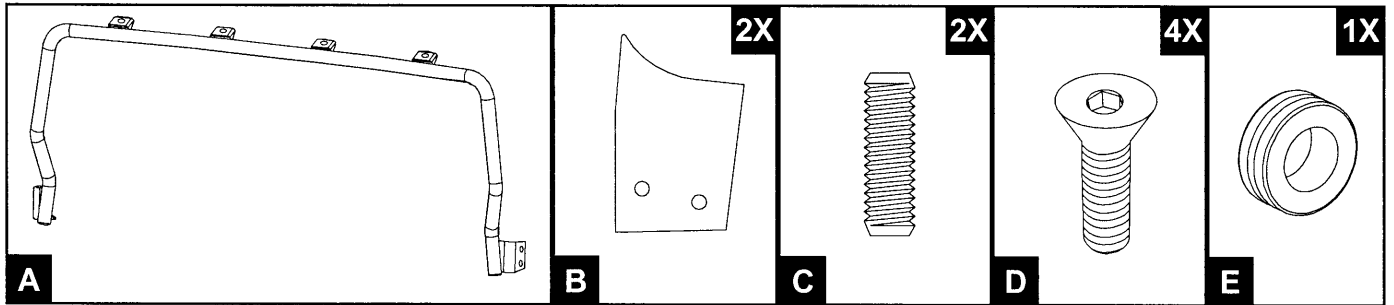

**NOTE:**  
All drilled holes should be de burred and treated with Mopar Corrosion Inhibitor # 82300508.

Maintain this product by cleaning with a mild detergent and protect with Mopar cleaner polish # 4796237

**NOTE:**  
One of the following kits will be required to complete the electrical installation.

\* Verify part number required for your model year application.

- 82202526 - (Installation kit off road lighting)
- 82208465 - (Installation kit off road lighting)



1

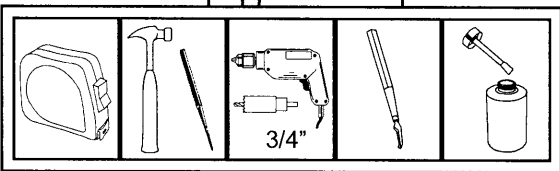

1/2" (13mm)

1-1/2" (38.5mm)

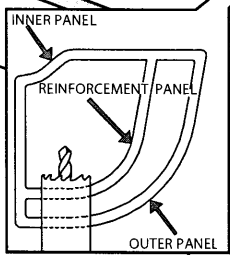
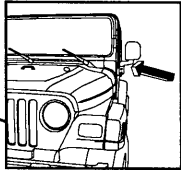

NOTE: HOLES NEED TO BE DRILLED THROUGH OUTER AND RE-INFORCEMENT PANELS, BUT NOT THROUGH INNER PANEL.

2

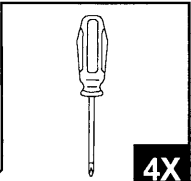
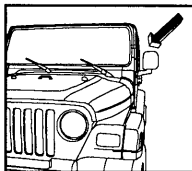

4X

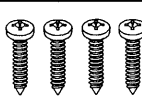

16

3

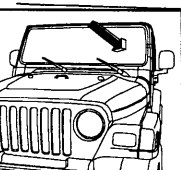

NOTE: A-PILLAR FOR 2003, 2004 AND 2005 MODEL YEARS ONLY.

4

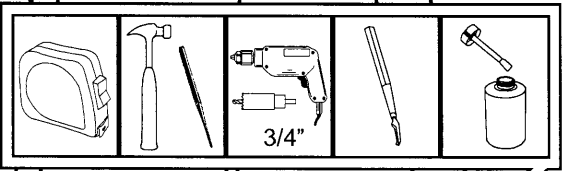

1" (25mm)

2-3/4" (70mm)

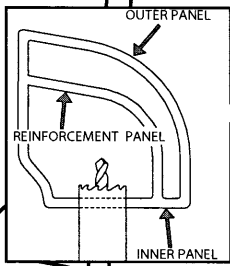

NOTE: DRILL THROUGH INNER PANEL ONLY.



5

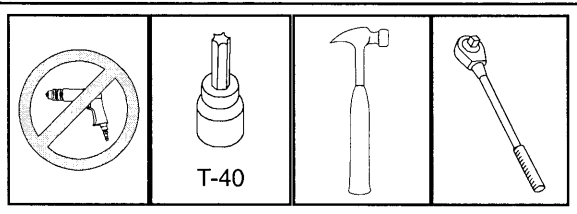

T-40

REMOVE TOP SCREWS ONLY.  
DO NOT USE POWERTOOLS.

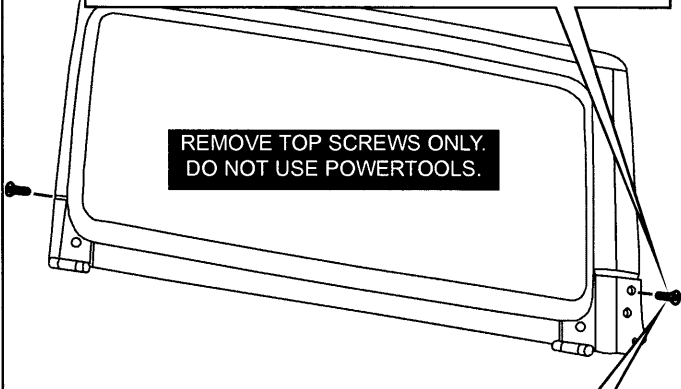

HINT: LIGHTLY TAP ALL (4)  
SCREWS (2 PER SIDE) WITH  
T-40 BIT AND HAMMER TO  
LOOSEN THREADS.

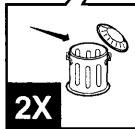

6

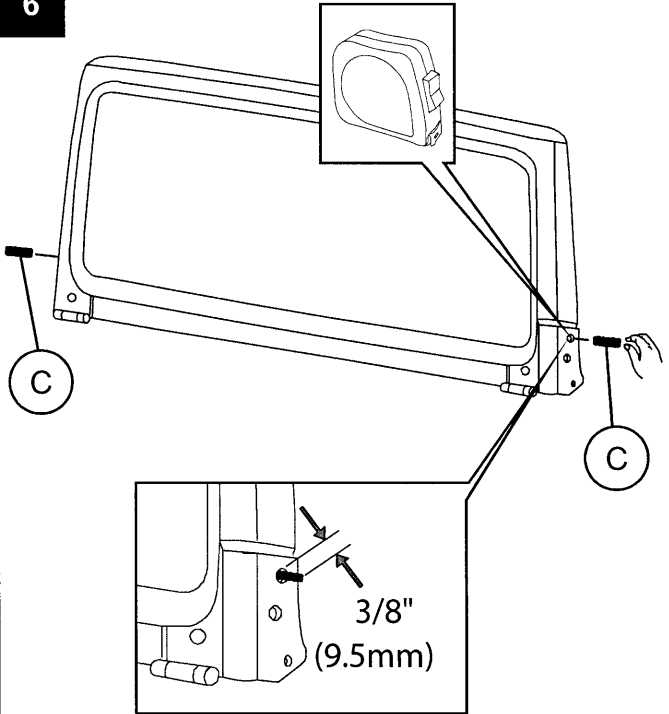

3/8"  
(9.5mm)

7

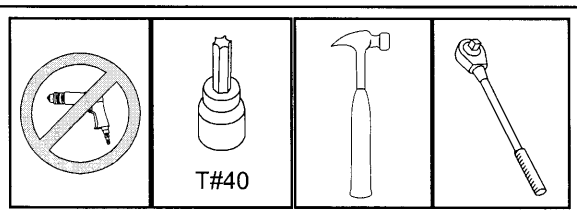

T#40

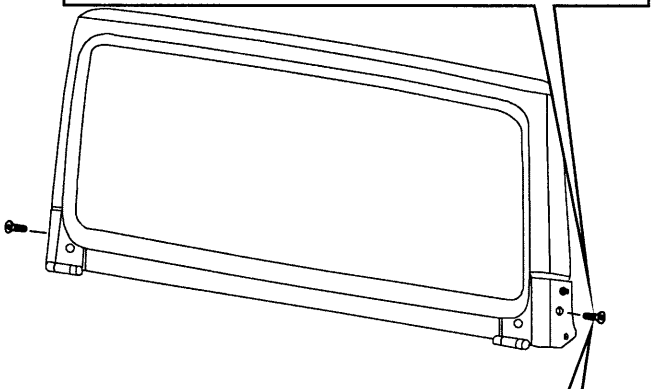

NOW REMOVE LOWER SCREWS.

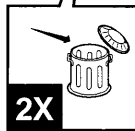

8

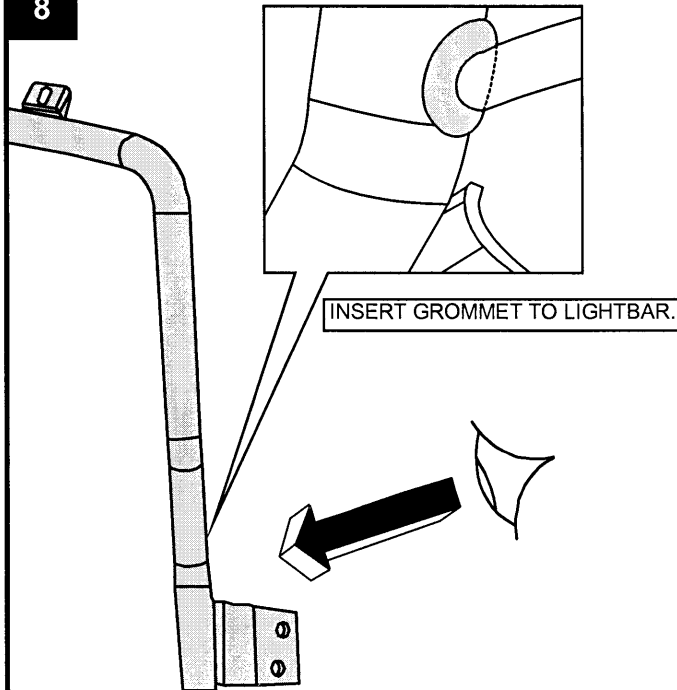

INSERT GROMMET TO LIGHTBAR.

9

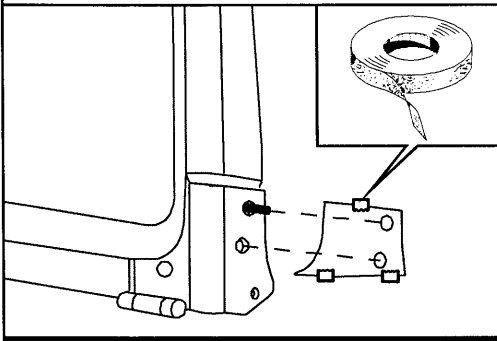
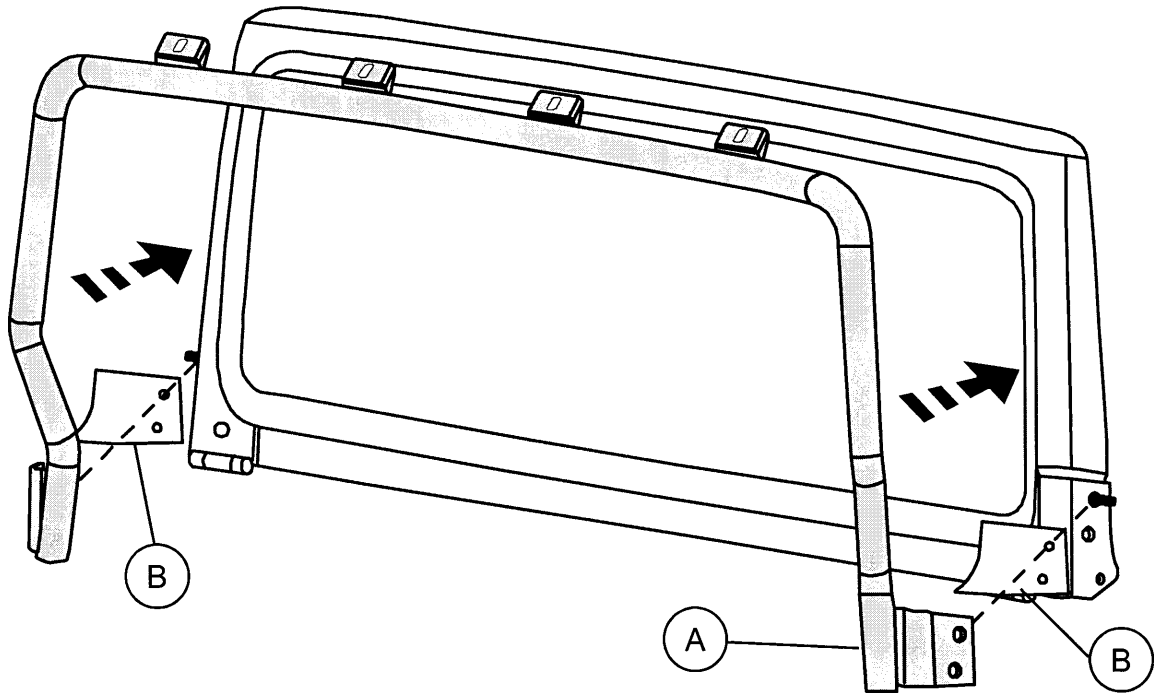

**HINT#1**  
TAPE THE GASKET (B) TO THE BODY AFTER ALIGNING TO THE HOLES AND BRACKET. REMOVE TAPE AFTER LIGHT BAR IS MOUNTED.

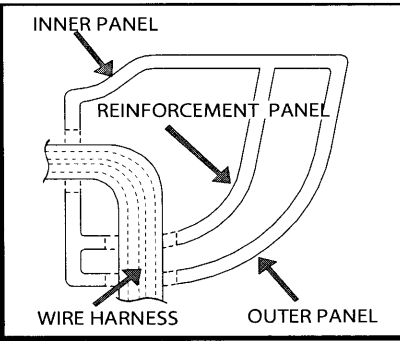

**HINT#2**  
FEED WIRE HARNESS INTO DRILLED HOLES, THROUGH ALL 3 PANELS.

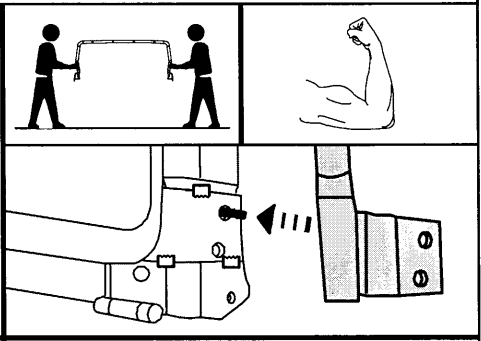

**HINT#3**  
WITH THE USE OF 2 PEOPLE, FIRST POSITION THE LIGHT BAR (A) BODY BRACKET OVER THE 5/16 STUD (C) ON THE DRIVER-SIDE. THEN DO THE SAME FOR THE PASSENGER SIDE.



10

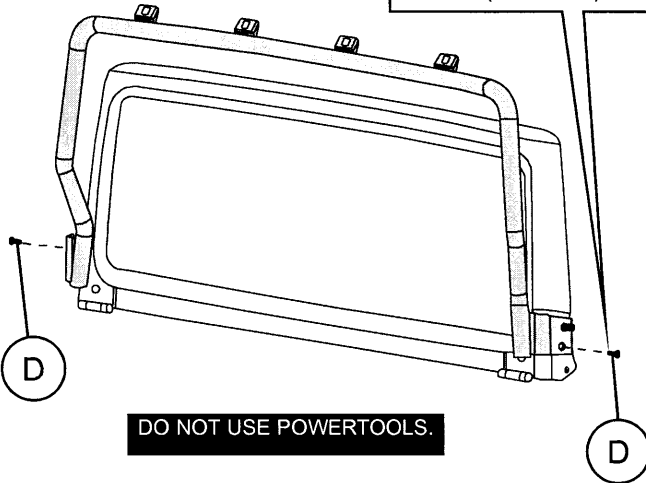
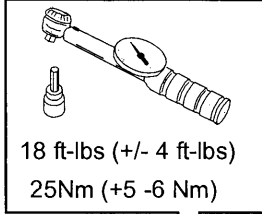
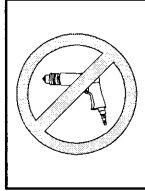

DO NOT USE POWERTOOLS.

11

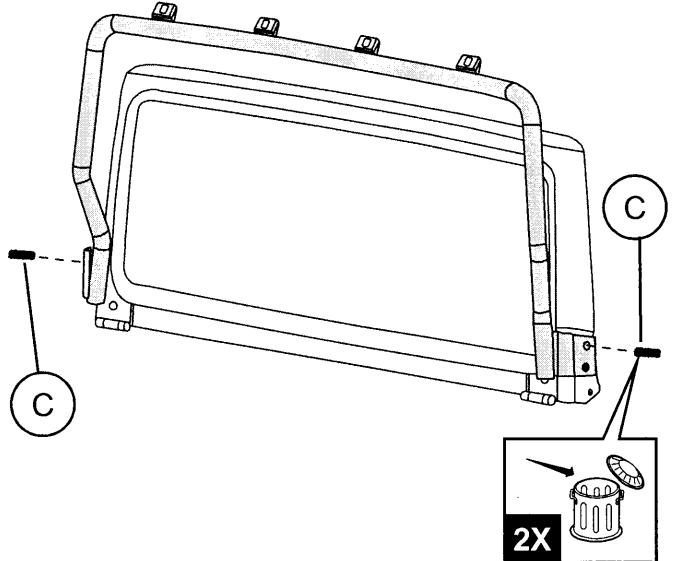

2X

12

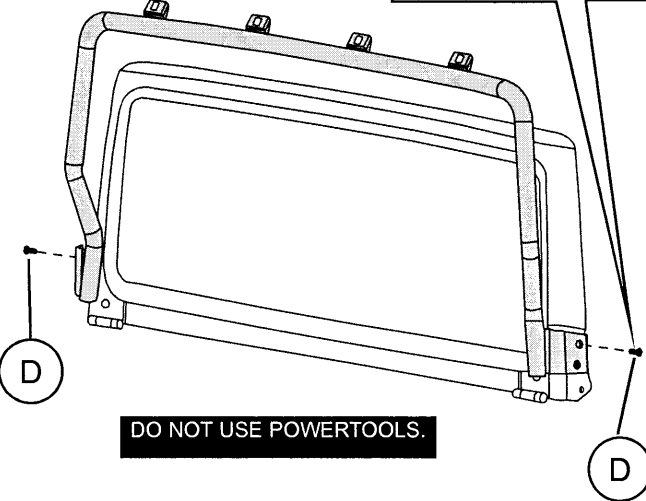
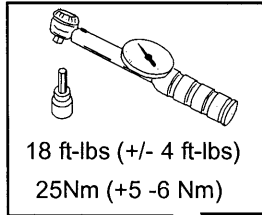
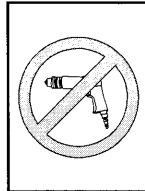

DO NOT USE POWERTOOLS.

13

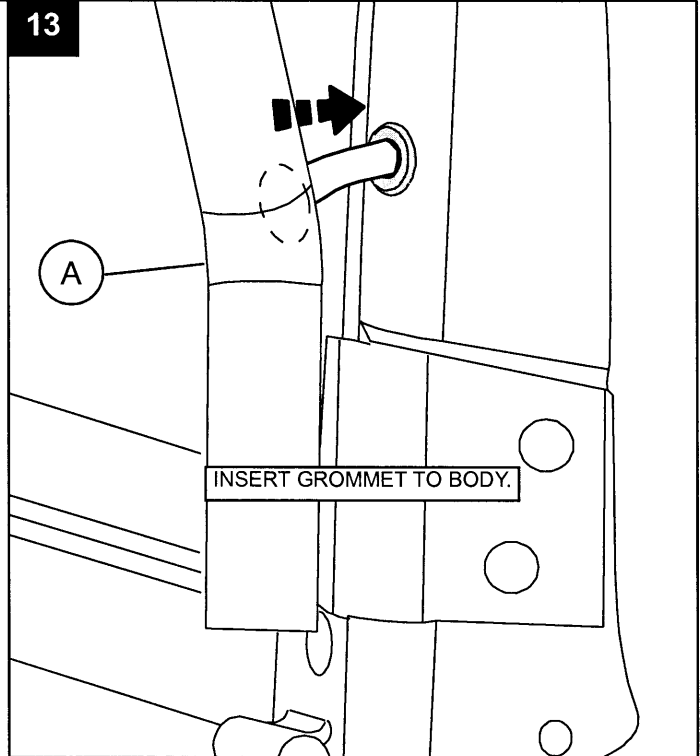

INSERT GROMMET TO BODY.

