

- Read installation procedure on pages 3/4/5 and harness alteration procedures on pages 6/7 before starting.
- Lea el procedimiento de instalación en las páginas 3/4/5 y los procedimientos de alteración del mazo de cables en las páginas 6/7 antes de comenzar.
- Lire les instructions d'installation des pages 3, 4 et 5, ainsi que les procédures de modification du faisceau des pages 6 et 7 avant de commencer.

NEWER "CAN-B" VEHICLES
 VEHÍCULOS NUEVOS CON "CAN-B"
 VÉHICULES « CAN B » RÉCENTS

CHRYSLER

2006 ⇒ PT CRUISER	8
300C	9

DODGE

2004 ⇒ DURANGO	10
2005 ⇒ DAKOTA	11
2006 ⇒ RAM	12
CALIBER	13
CHARGER	9
MAGNUM	9

JEEP

2005 ⇒ GRAND CHEROKEE	14
COMMANDER	15
COMPASS	16

OLDER "J1850" VEHICLES
 VEHÍCULOS ANTERIORES CON "J1850"
 VÉHICULES « J1850 » ANCIENS

CHRYSLER

2002-05 PT CRUISER	17
300M	18
CONCORDE	18
PACIFICA	19
SEBRING SEDAN	20
TOWN & COUNTRY	21

DODGE

2002-03 DURANGO	22
2002-04 DAKOTA	22
2000-05 RAM	23
CARAVAN	21
INTREPID	18
NEON	24
STRATUS	20

JEEP

2002-04 GRAND CHEROKEE	25
LIBERTY	26

1990-2001 VEHICLES ONLY

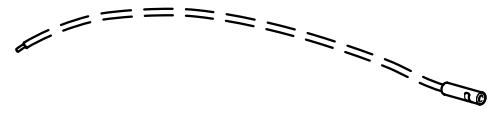

A1 04720928—See page 7 of 27

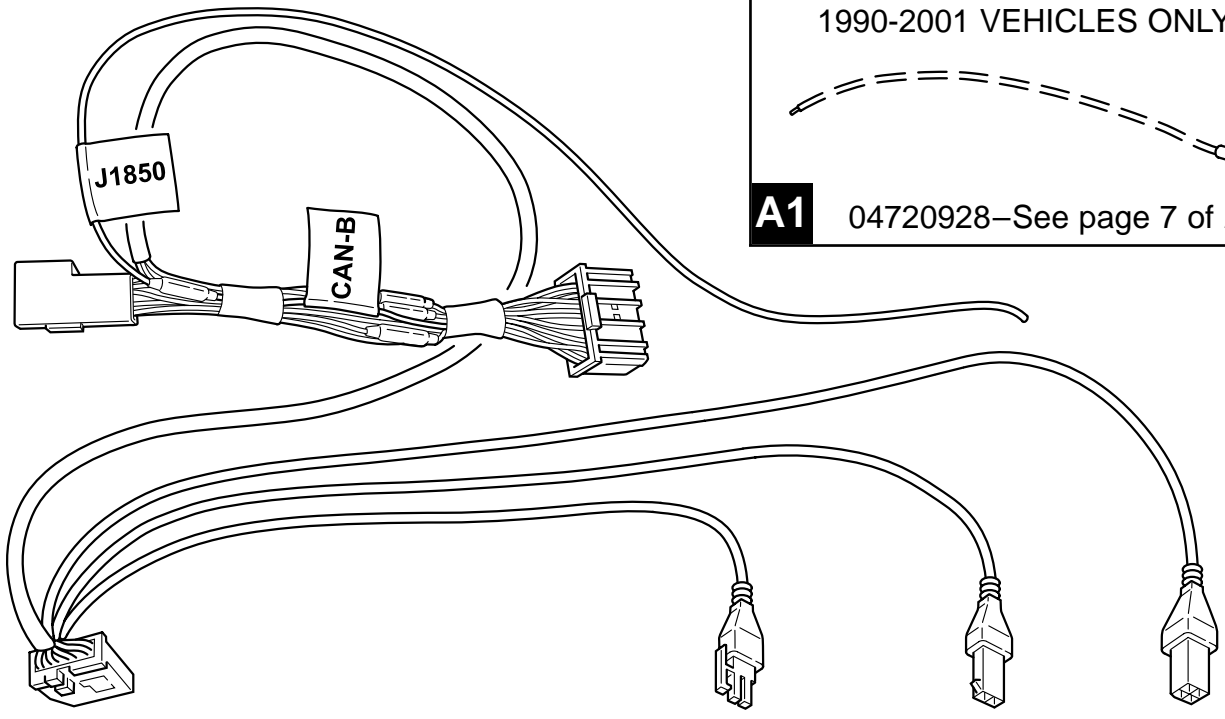

A

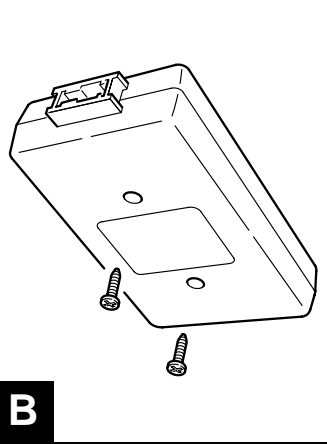

B

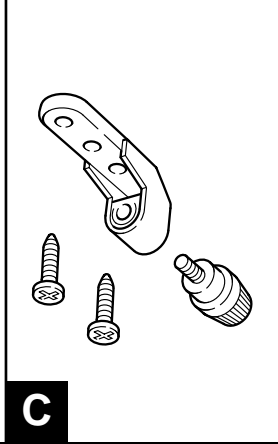

C

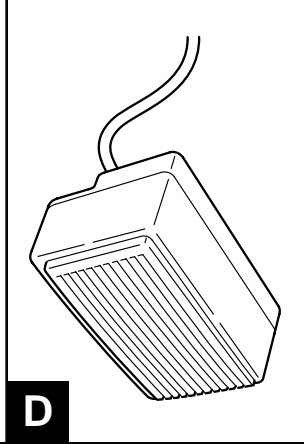

D

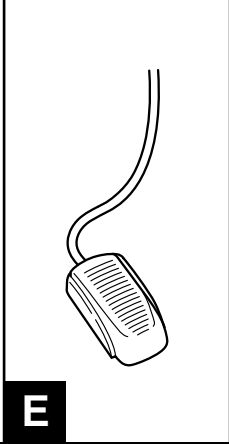

E

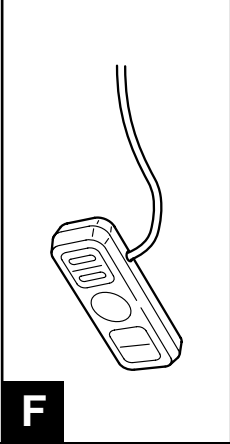

F

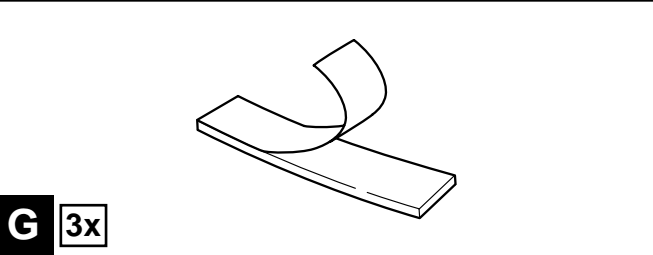

G 3x

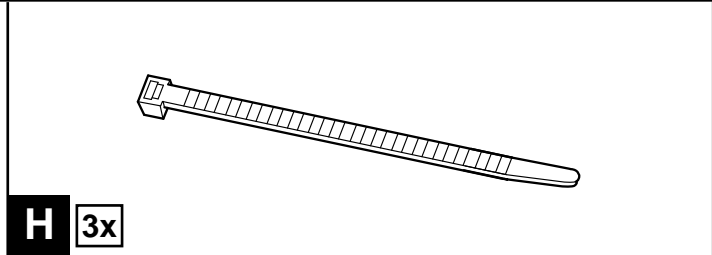

H 3x

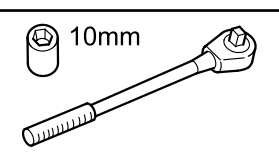

10mm

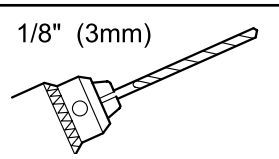
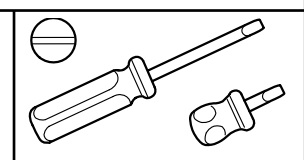
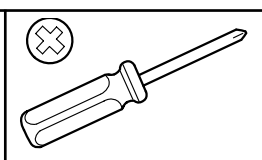
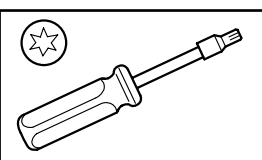
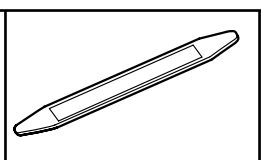

1/8" (3mm)

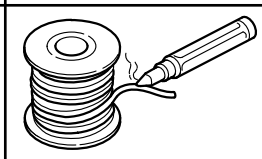
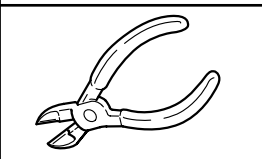
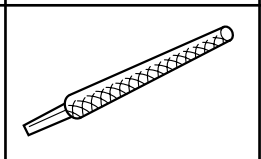

INSTALLATION PROCEDURE

GB

- **Disconnect and isolate negative battery cable.**
- Disconnect and remove overhead console or front dome lamp.
- Remove left (driver's side) A-pillar trim panel and left instrument panel side cover.
- Remove instrument panel center cluster bezel. Disconnect and remove radio.
- Remove knee blocker panel(s) on older vehicles only.
- Route 22-way harness connectors (Item A) and control pad cable connector (Item F) up into the instrument panel at the knee blocker opening, and out of the radio opening. Keep away from sharp edges, heat sources, or moving parts.
- Install kit components as described in notes and as shown in illustrations. Ensure that all vehicle mounting surfaces are clean.

ITEM B:

Place supplied 2-way tape to underside of module. Ensure tape contacts to vehicle mounting surfaces. Install tie straps and mounting screws if needed.

ITEM C:

Measure for bracket mounting holes as shown in illustrations. Using the bracket as a template, drill two 1/8" holes. Install bracket with supplied screws.

ITEM D:

Install speaker to mounting bracket. Position speaker as shown in illustrations. Tighten thumb screw with flat blade screwdriver (do not overtighten).

ITEM E:

Remove backing from 2-way tape at underside of microphone. Install mic to overhead console or front dome lamp. Using a small circular file, make a notch in the console/dome lamp bezel edge closest to the mic. Route mic cable under headliner towards left A-pillar.

ITEM F:

Secure control pad cable inside trough at the back of the unit. Remove backing from 2-way tape at underside of control pad. Install control pad to I/P center console bezel. Using a small circular file, make a notch in the inner edge of the radio or HVAC opening closest to the control pad.

2002-2006 Vehicles: Refer to page 6 for vehicle specific harness instructions. Plug 22-way harness connectors into radio and radio connector.

1990-2001 Vehicles: Follow procedure shown on page 7. Securely crimp a ground eyelet or a blade terminal to the black wire.

- Make electrical connections to items B, D, E, and F. When connecting to module (Item B) make sure connector lever is engaged in the locked position.
- Loop-up slack in harness and cables. Apply tie straps and stow away neatly. Do not kink or tightly coil the cables.
- Re-install vehicle components and trim panels, ensuring that cables are not pinched under them.
- Re-connect negative battery cable.
- Perform a functional check of the system by following the steps shown on page 27 of this document.

PROCEDIMIENTO DE INSTALACIÓN

E

- **Desconecte el cable negativo de la batería y aísolelo.**
- Desconecte la consola de techo o la luz de domo del frente y retírela.
- Retire el panel de guarnición del pilar A izquierdo (lado del conductor) y la cubierta del costado izquierdo del tablero de instrumentos.
- Retire el reborde del grupo de instrumentos del centro del tablero de instrumentos. Desconecte el radio y retírelo.
- Retire el o los paneles para rodillas sólo de los vehículos de modelos anteriores.
- Pase los conectores del mazo de cables de 22 vías (Elemento A) y el conector de cables del cojín de control (Elemento F) hacia arriba y adentro del tablero de instrumentos en la abertura del panel para rodillas y sáquelo por la abertura del radio. Mantenga alejado de bordes filosos, fuentes de calor o piezas móviles.
- Instale los componentes del juego según se describe en las notas y como se muestra en las ilustraciones. Asegúrese de que todas las superficies de montaje del vehículo estén limpias.

ELEMENTO B:

Coloque la cinta de dos caras en la parte inferior del módulo. Asegúrese de que la cinta hace contacto con las superficies de montaje del vehículo. Instale correas de sujeción y tornillos de montaje si es necesario.

ELEMENTO C:

Mida los orificios del soporte de montaje según se muestra en las ilustraciones. Utilizando el soporte como plantilla, haga agujeros de 3.2 mm (1/8"). Instale el soporte con los tornillos suministrados.

ELEMENTO D:

Instale la bocina al soporte de montaje. Coloque la bocina según se muestra en las ilustraciones. Ajuste el tornillo con orejas con un destornillador de hoja plana (no ajuste de más).

ELEMENTO E:

Remueva la película protectora de la cinta de 2 caras en la parte inferior del micrófono. Instale el micrófono a la consola de techo o a la luz de domo central (si cuenta con una). Utilizando una lima circular pequeña, realice un calado en el reborde de la consola o de la lámpara de domo que esté más cercano al micrófono. Pase el cable del micrófono por debajo del forro del techo hacia el pilar A izquierdo.

ELEMENTO F:

Asegure el cable del cojín de control dentro de la canaleta por detrás de la unidad. Remueva la película protectora de la cinta de 2 caras en la parte inferior del cojín de control. Instale el cojín de control al reborde de la consola central del tablero de instrumentos utilizando una lima circular pequeña, realice un calado en el borde interno de la abertura del radio o del HVAC más cercana al cojín de control.

Vehículos 2002-2006: Consulte la página 6 para obtener instrucciones acerca del mazo de cables específico para su vehículo. Enchufe los conectores de 22 vías del al radio y al conector del radio.

Vehículos 1990-2001: Siga el procedimiento que se muestra en la página 7. Embayete firmemente un ojal para conexión a tierra o un terminal tipo espada al cable negro.

- Realice las conexiones eléctricas a los elementos B, D, E y F. Cuando lo conecte al módulo (Elemento B) asegúrese de que la palanca del conector se encuentre bloqueada.
- Forme un lazo con la holgura del mazo y los cables. Coloque correas de sujeción y acomode bien. No retuerza ni enrolle los cables en forma ajustada.
- Vuelva a instalar los componentes del vehículo y los paneles de guarnición, asegurándose de que no queden cables apretados bajo los mismos.
- Vuelva a conectar el cable negativo de la batería.
- Realice una verificación funcional del sistema siguiendo los pasos que aparecen en la página 27 de este documento.

F

- **Débrancher et isoler le câble négatif de la batterie.**
- Déconnecter et retirer la console au plafond ou le plafonnier avant.
- Retirer l'habillage du montant de portière A côté gauche (conducteur), et le couvercle de tableau de bord gauche.
- Retirer l'encadrement central du tableau de bord. Débrancher et retirer la radio.
- Sur les véhicules anciens seulement, retirer le(s) rembourrage(s) de genoux.
- Acheminer les connecteurs à 22 voies (article A) et le connecteur du câble du boîtier de commande (article F) vers le haut, jusqu'au tableau de bord, au niveau de l'ouverture du rembourrage de genoux et les faire sortir par l'ouverture de la radio. Garder les fils à l'écart des bords tranchants, sources de chaleur et pièces mobiles.
- Installer les pièces du nécessaire selon les directives et illustrations fournies. S'assurer de la propreté de toutes les surfaces de montage sur le véhicule.

ARTICLE B:

Appliquer le ruban adhésif double-face fourni sur la partie inférieure du module. S'assurer que l'adhésif est bien en contact avec les surfaces de montage du véhicule. Si nécessaire, utiliser des courroies d'attache et des vis de montage.

ARTICLE C:

Prendre les mesures pour les trous de montage du support tel qu'illustré. Percer deux trous de 1/8 po en utilisant le support comme gabarit. Fixer le support à l'aide des vis fournies.

ARTICLE D:

Fixer le haut-parleur au support de montage. Positionner le haut-parleur tel qu'illustré. Serrer modérément la vis à oreilles à l'aide d'un tournevis à lame plate.

ARTICLE E:

Retirer la pellicule protectrice du ruban double-face appliqué sous le microphone. Monter le microphone sur la console au pavillon ou sur le plafonnier, selon l'équipement. À l'aide d'une petite lime ronde, pratiquer une encoche dans le rebord de l'enjoliveur de la console/plafonnier situé le plus près du microphone. Acheminer le fil du microphone sous la garniture de pavillon, en direction du pied avant.

ARTICLE F:

Loger le câble du bloc de commande dans le chemin de câble situé à l'arrière de celui-ci. Retirer la pellicule protectrice du ruban double-face appliqué sous le bloc de commande. Monter le bloc de commande sur l'encadrement de la console centrale de tableau de bord. À l'aide d'une petite lime ronde, pratiquer une encoche dans le rebord intérieur de l'ouverture de la radio ou du système de chauffage/climatisation situé le plus près du bloc de commande.

Modèles 2002 à 2006: Voir la page 6 pour les instructions propres au faisceau de fils du véhicule. Brancher les connecteurs à 22 voies à la radio et au connecteur de radio.

Modèles 1990 à 2001: observer les directives de la page 7. Sertir un œillet de masse ou une cosse plate sur le fil noir.

- Procéder aux raccordements électriques des articles B, D, E, et F. Lors de la connexion du module (article B), s'assurer que le levier du connecteur est en position de verrouillage.
- S'assurer que le faisceau de câblage et les fils sont suffisamment tendus. Utiliser des courroies d'attache au besoin. Éviter de plier les fils ou de les enrouler de façon trop serrée.
- Réinstaller les composants et panneaux de garniture du véhicule en s'assurant de ne pincer aucun câble.
- Rebrancher le câble négatif de la batterie.
- Suivre les instructions de la page 27 de ce document pour effectuer une vérification du fonctionnement.

NEWER "CAN-B" VEHICLES

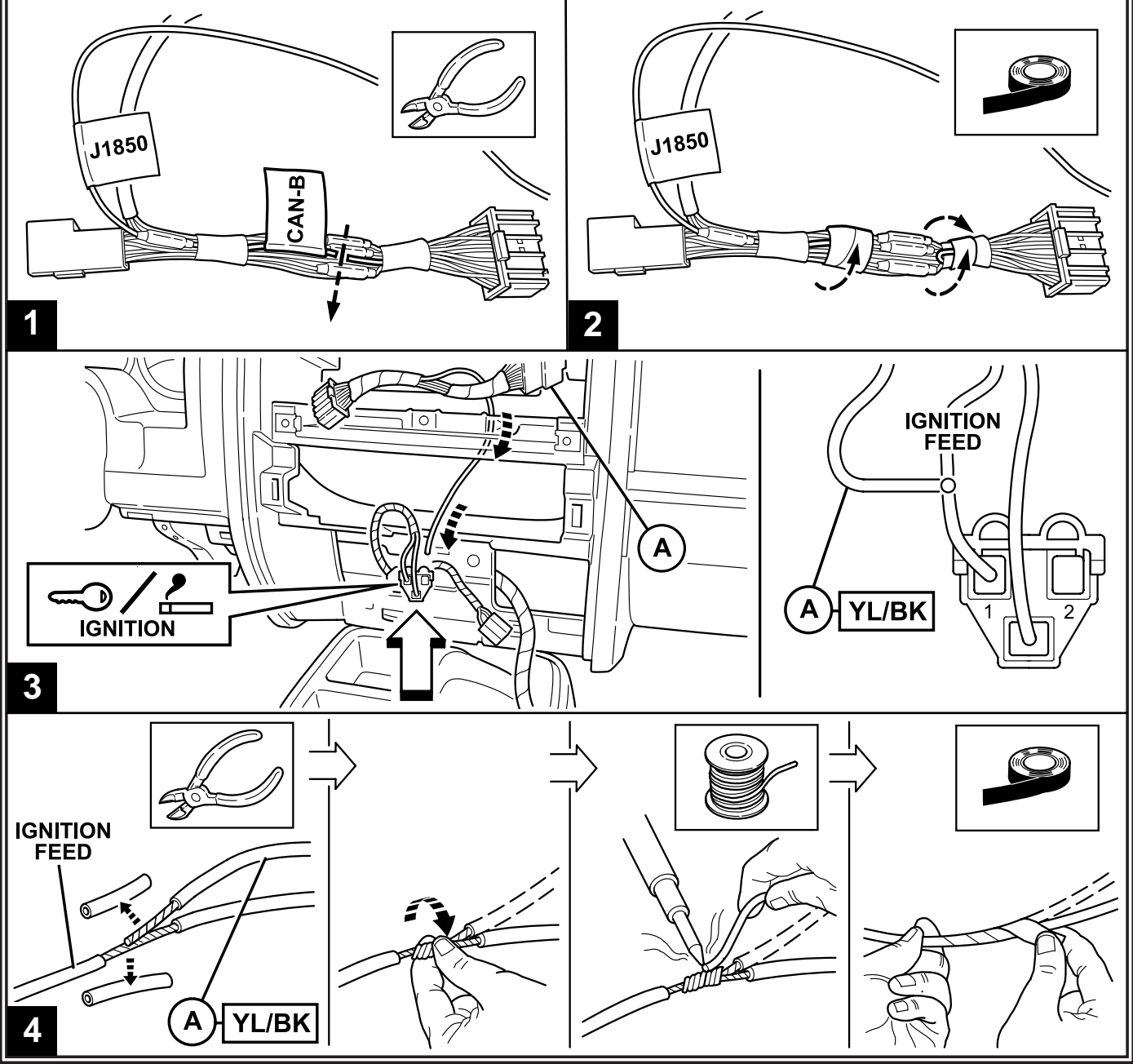

OLDER "J1850" VEHICLES

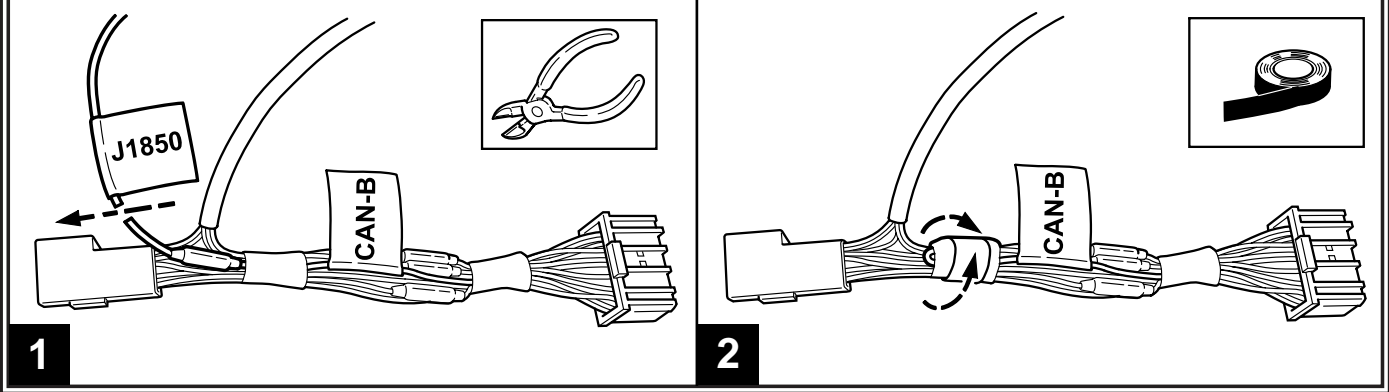

1990-2001 VEHICLES

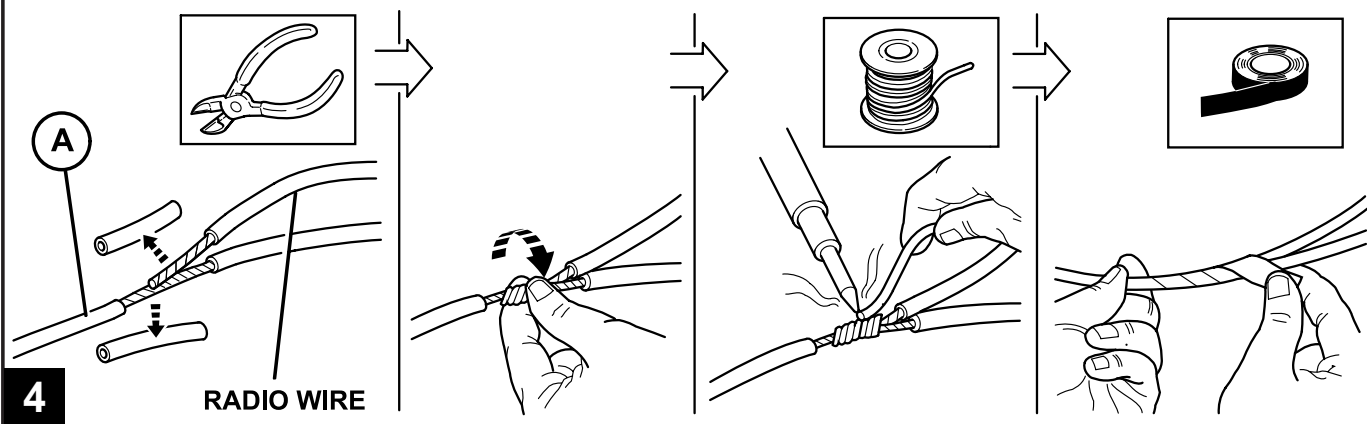
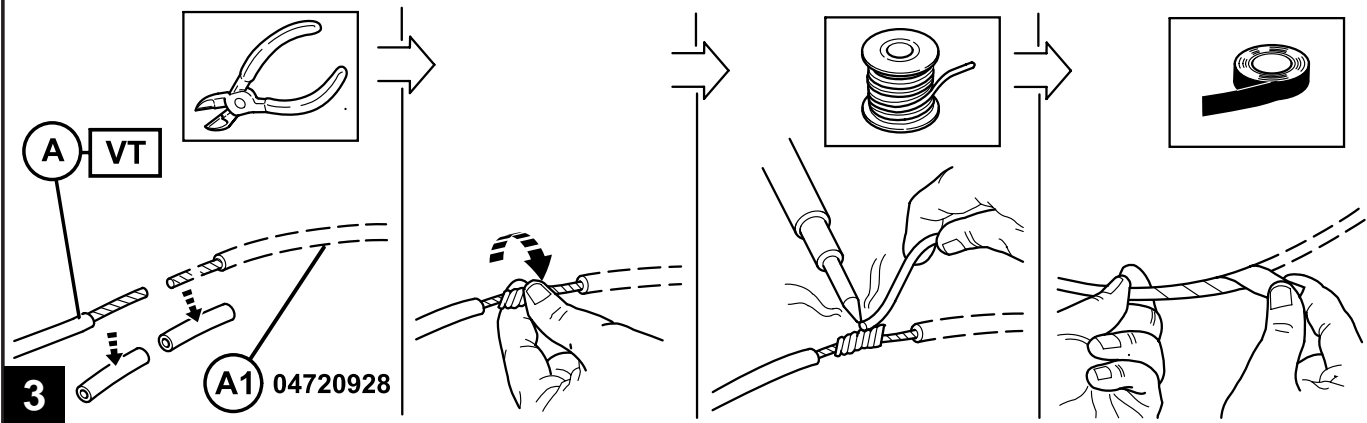
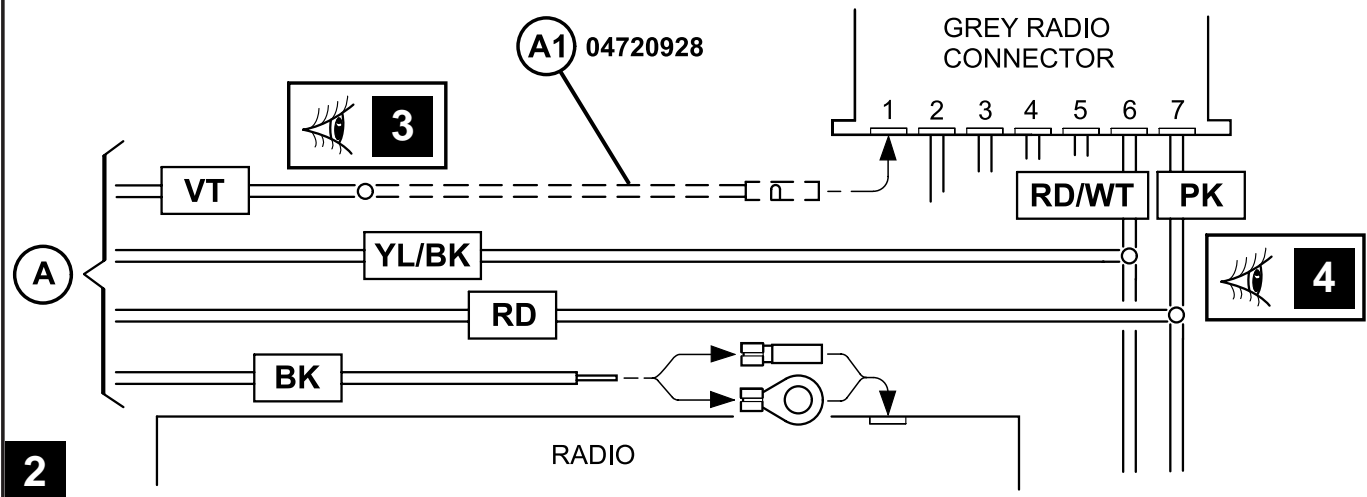
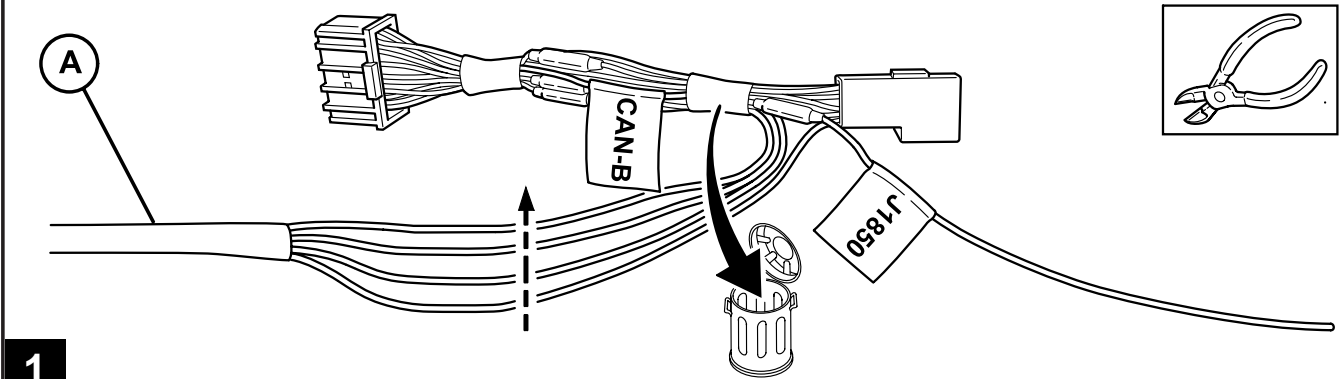

2006 ⇒ CHRYSLER PT CRUISER

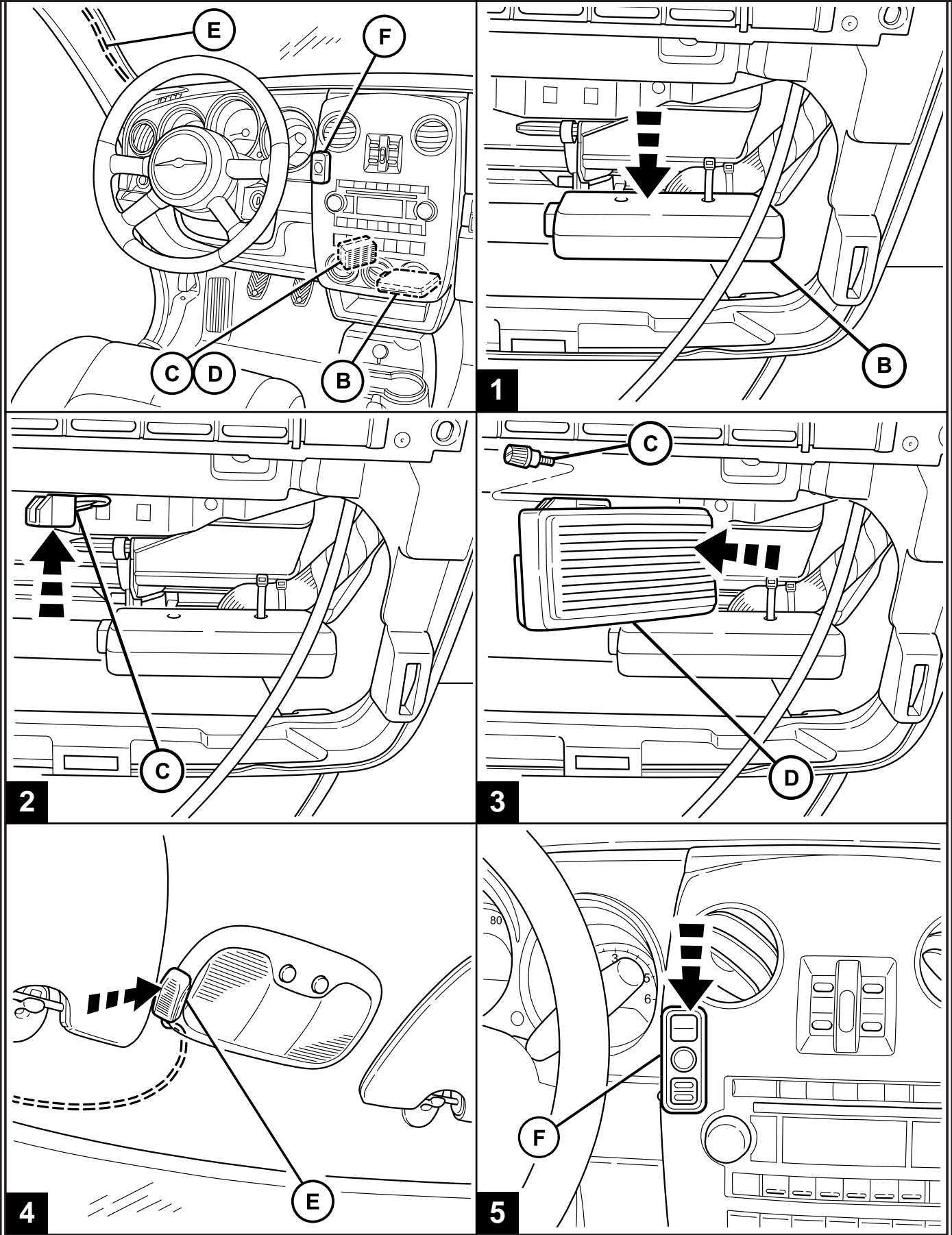

CHRYSLER 300C/DODGE MAGNUM, CHARGER

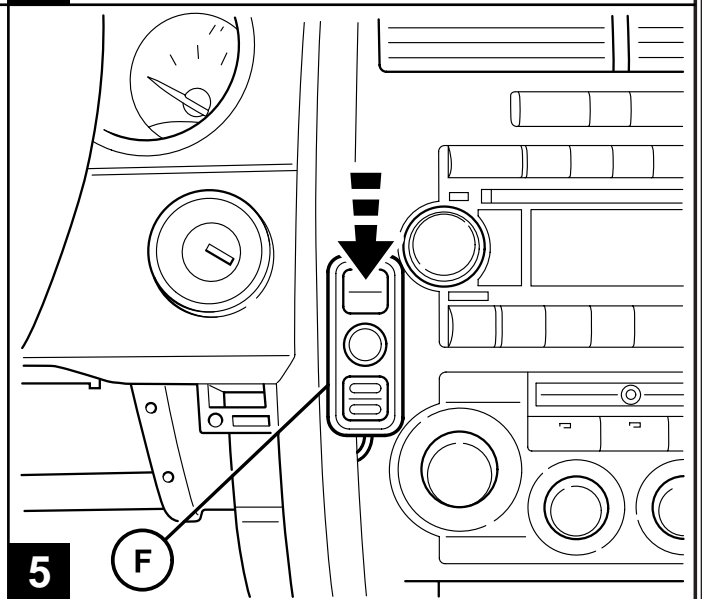
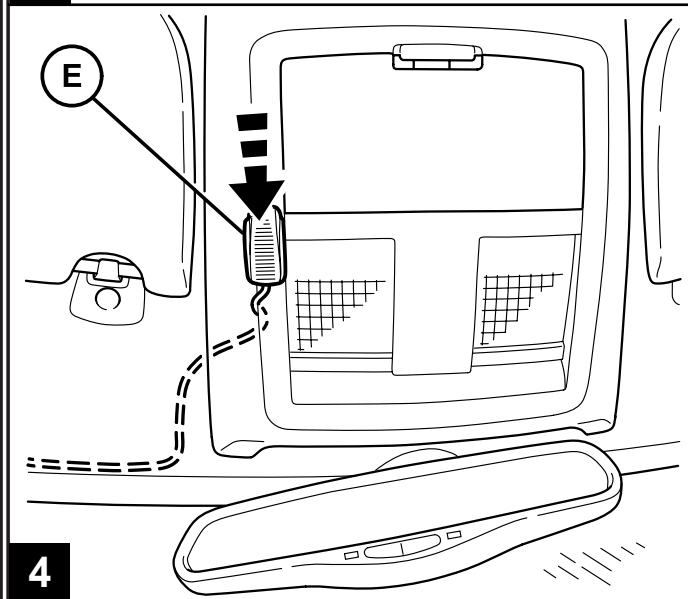
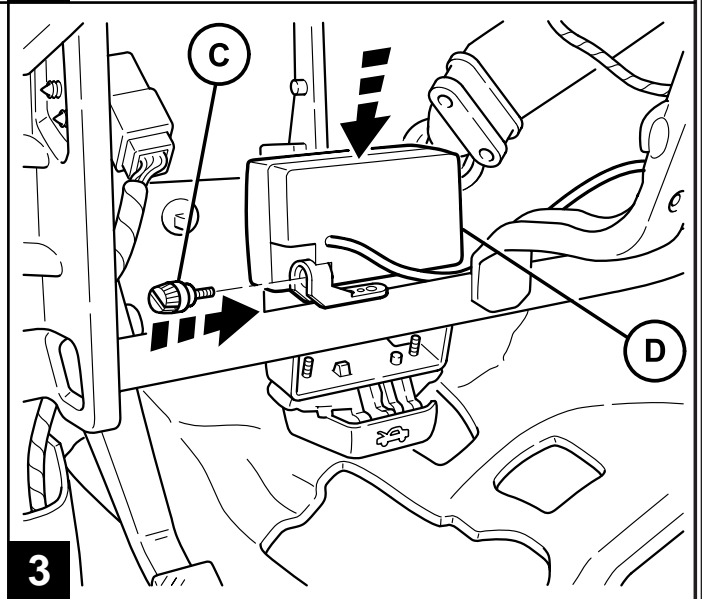
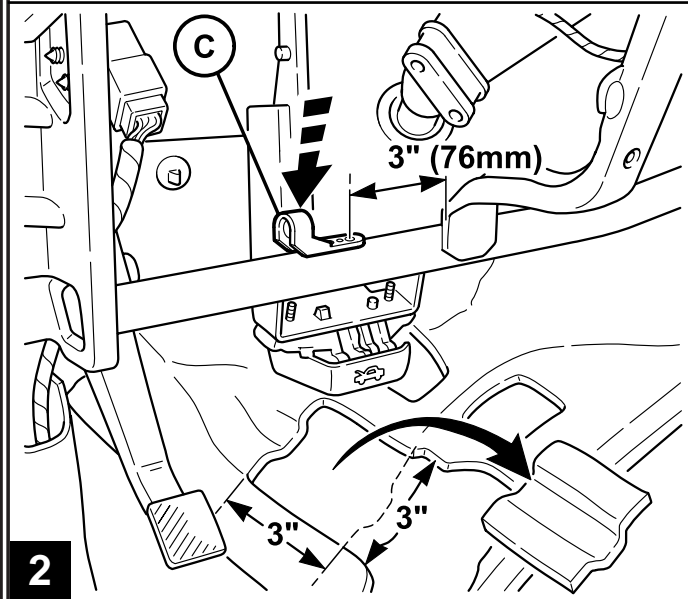
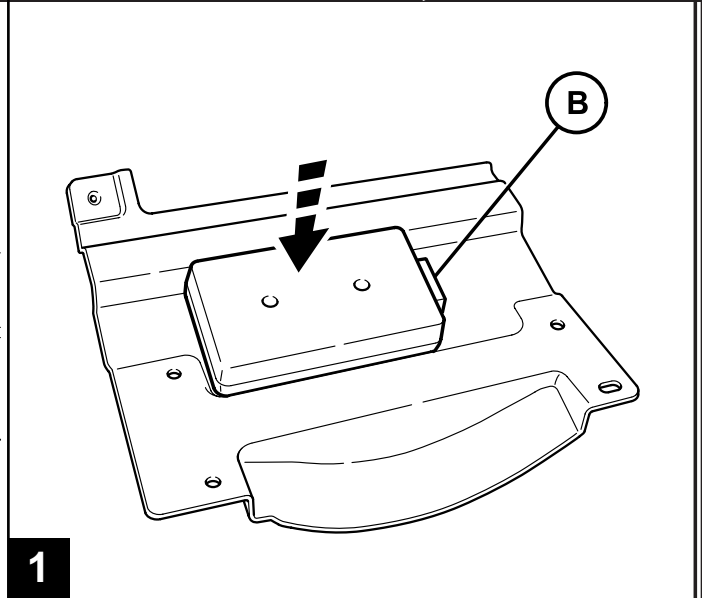
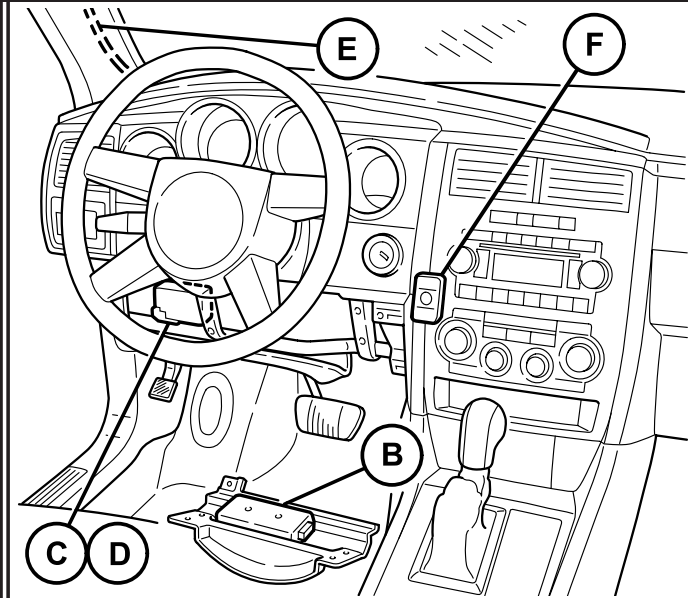

2004 ⇒ DODGE DURANGO

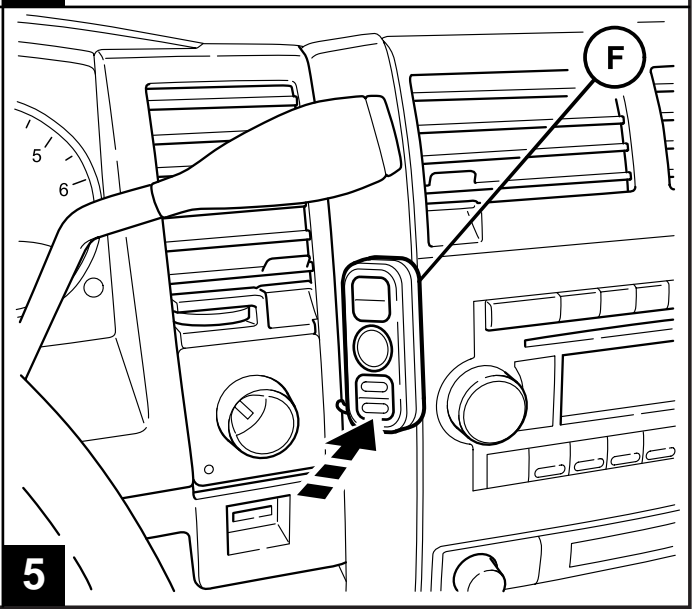
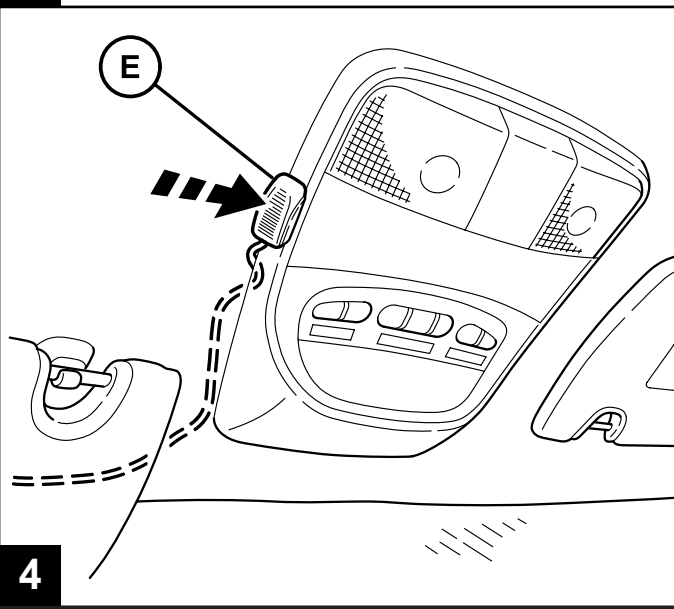
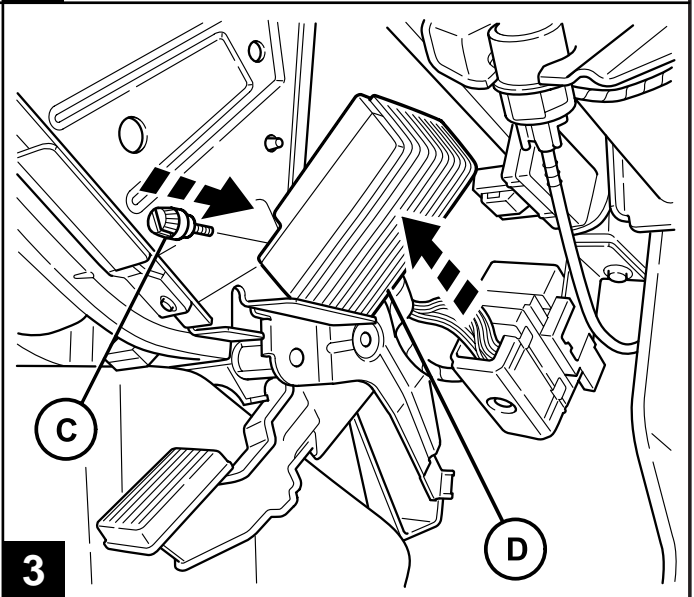
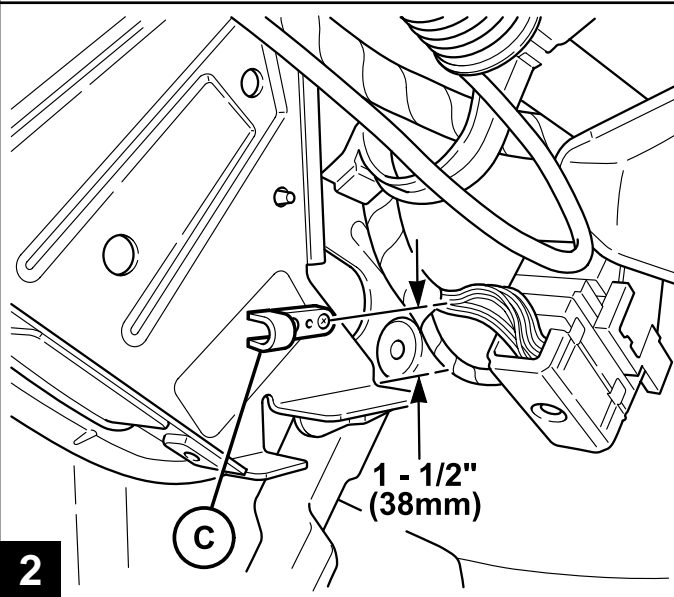
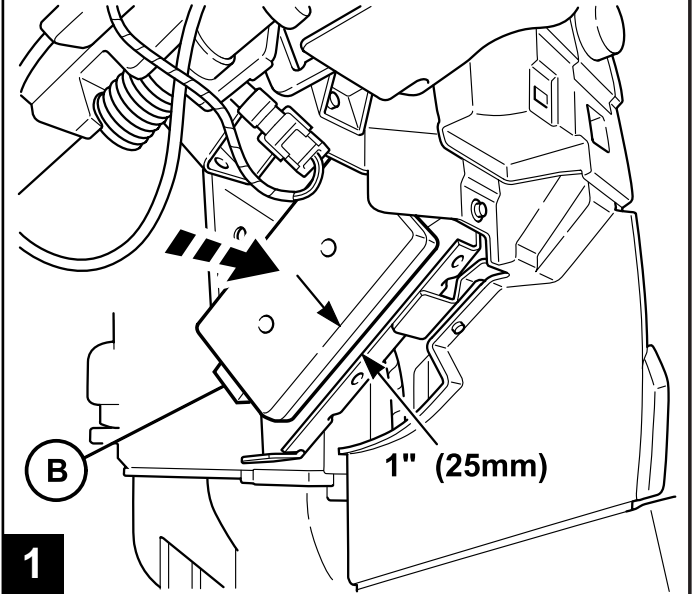
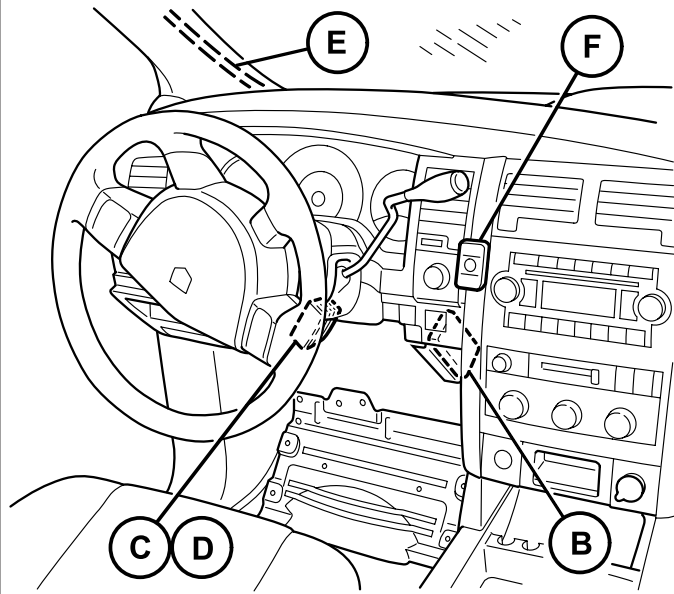

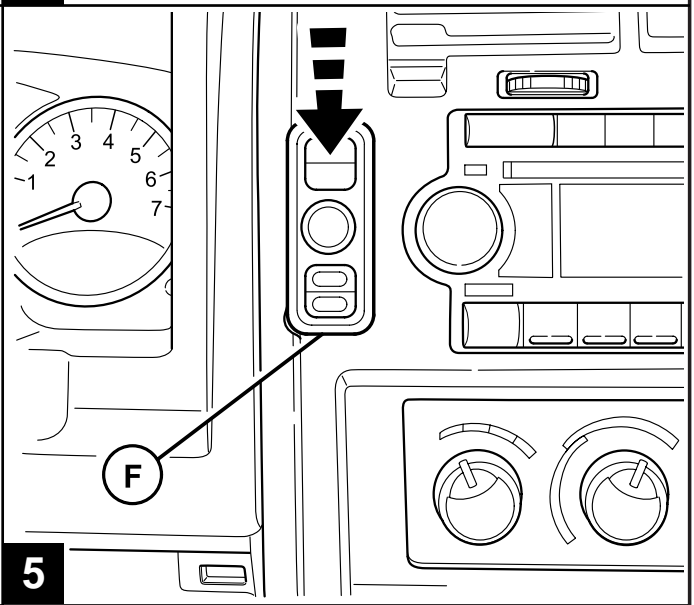
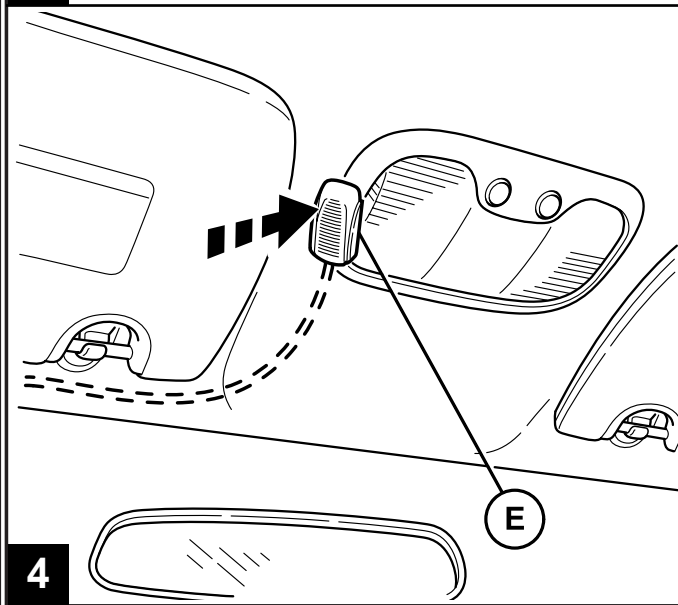
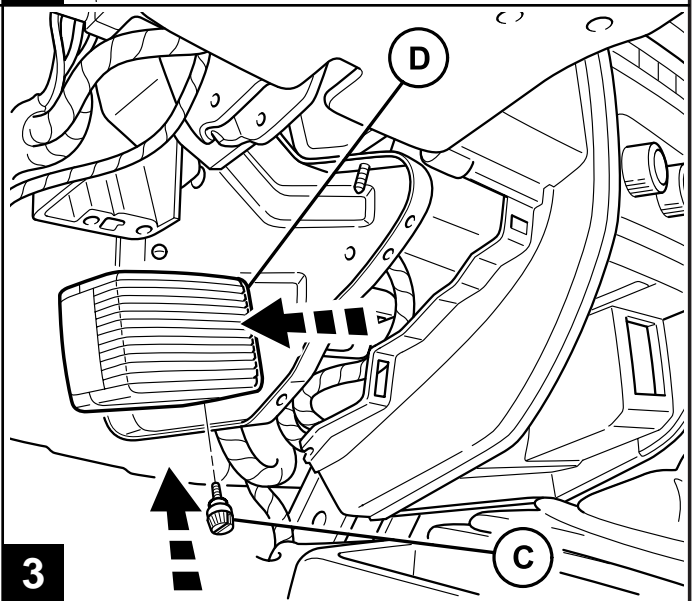
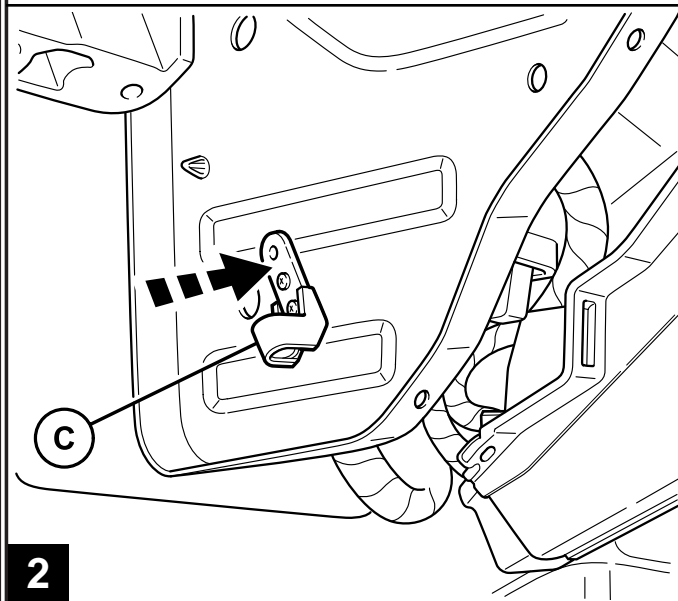
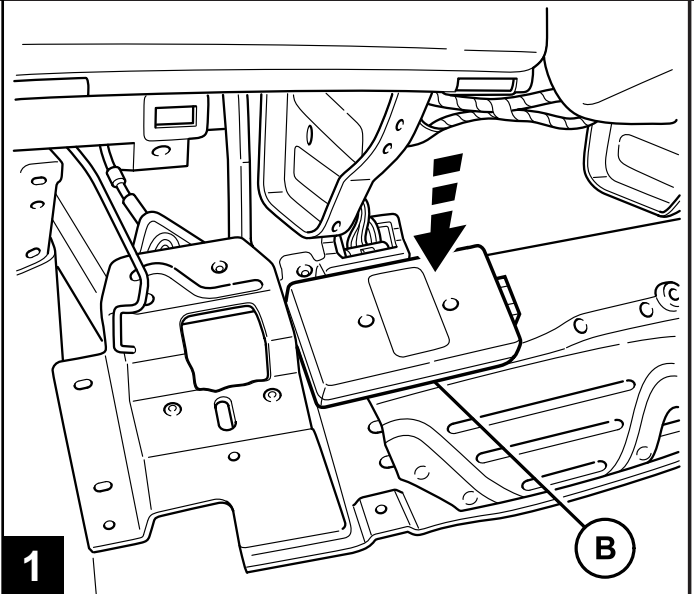
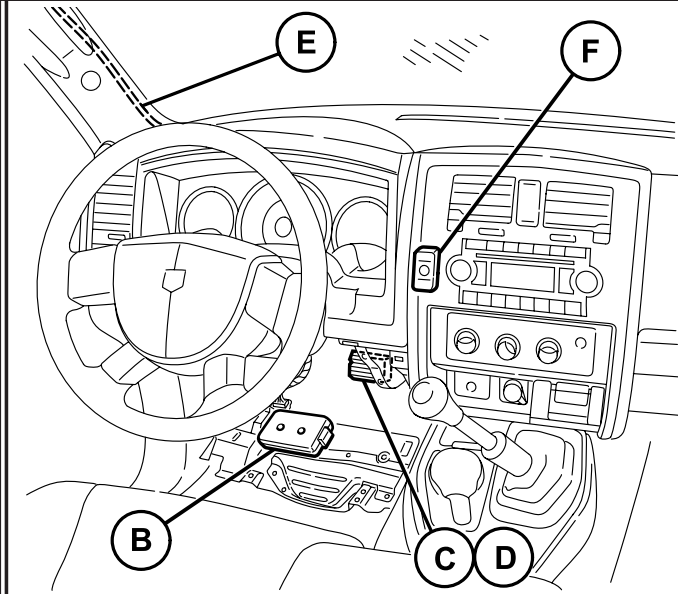

2006 ⇒ DODGE RAM

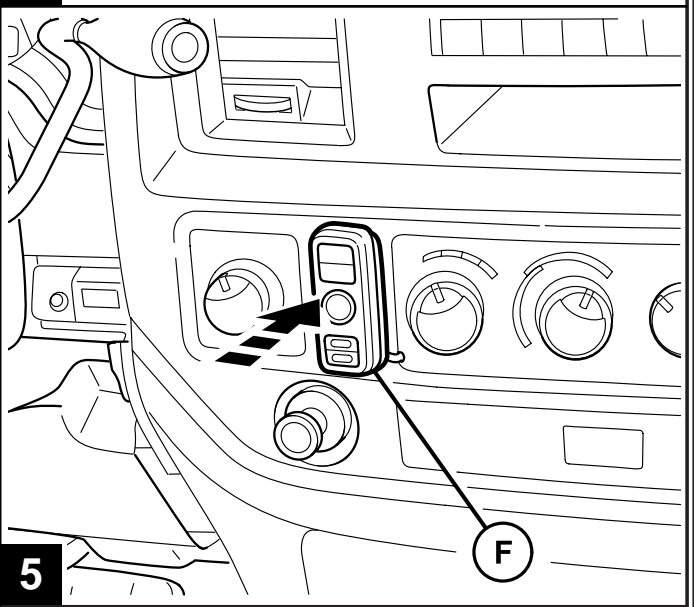
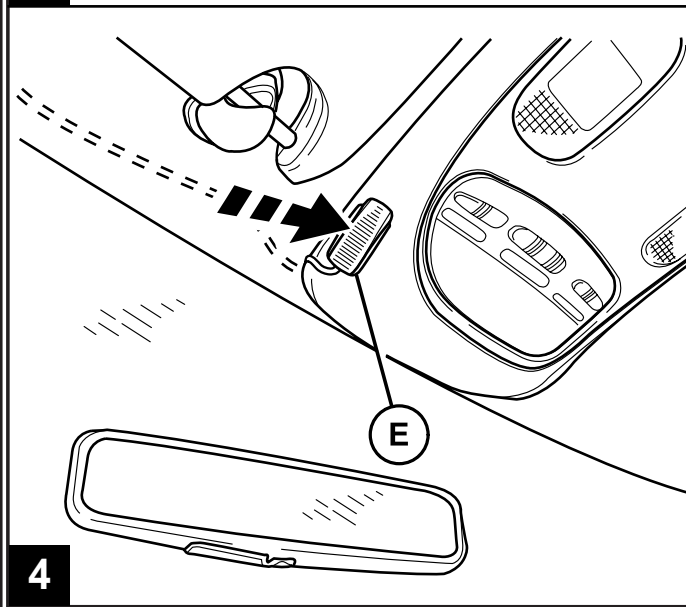
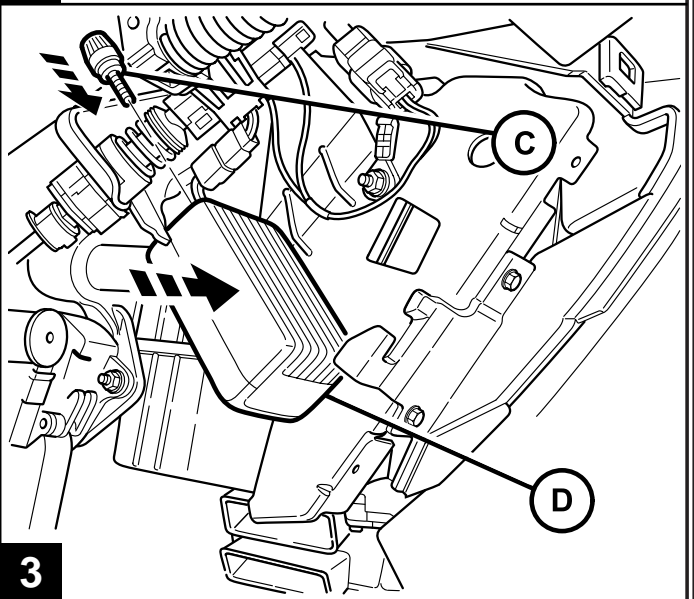
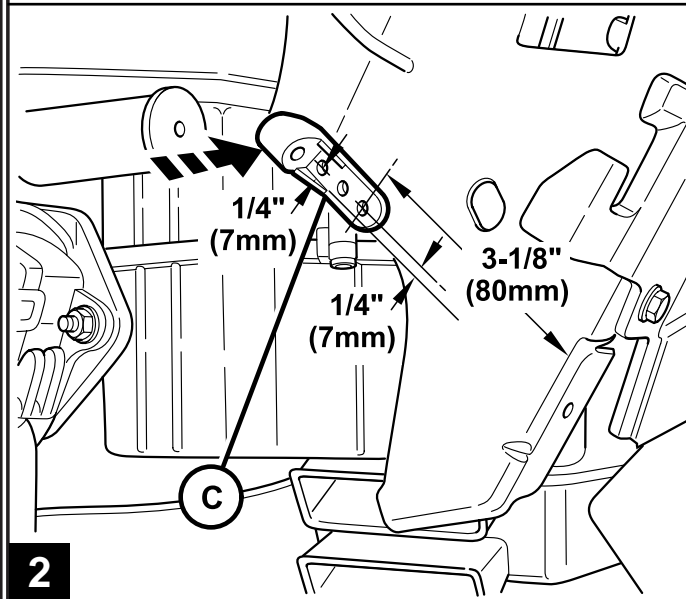
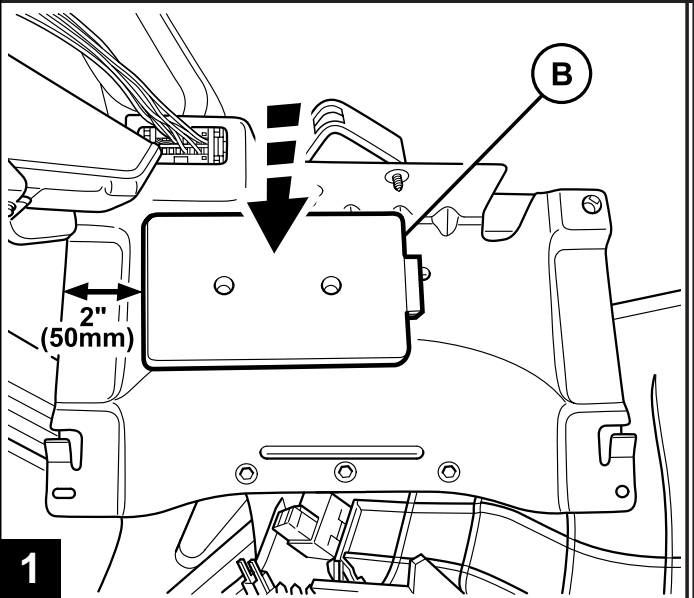
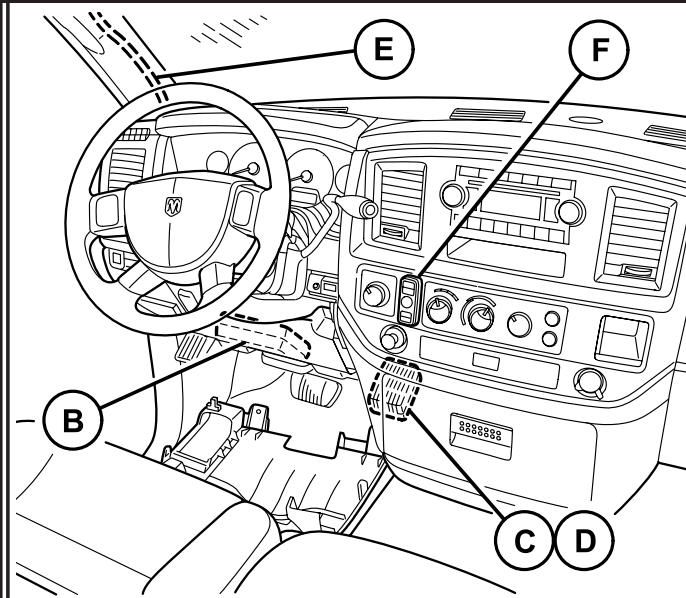

DODGE CALIBER

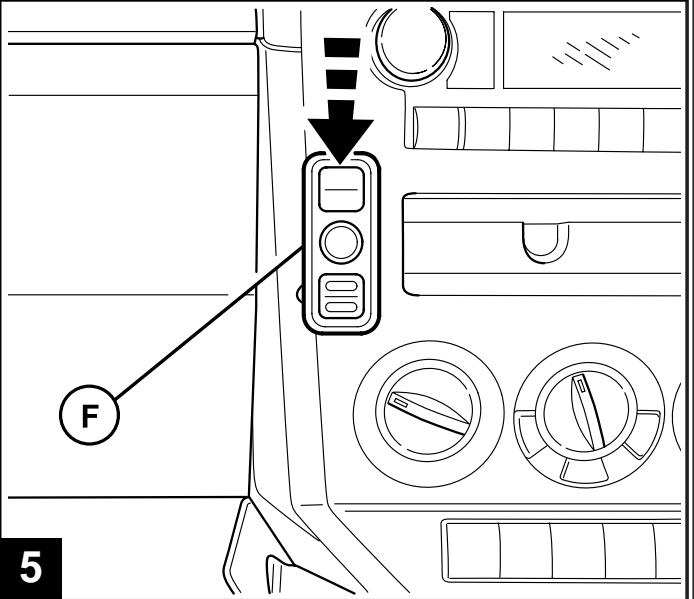
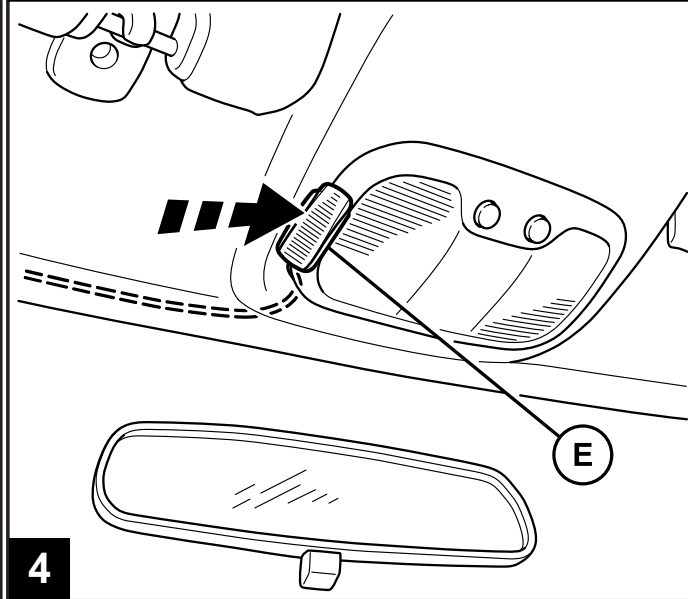
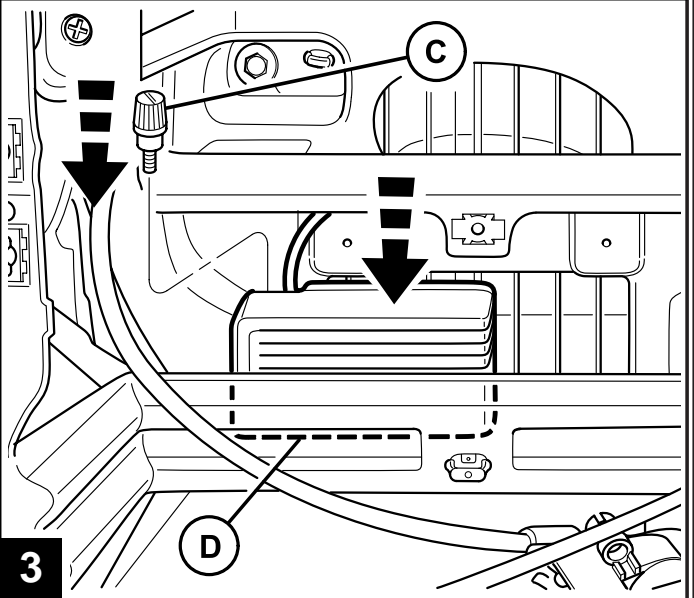
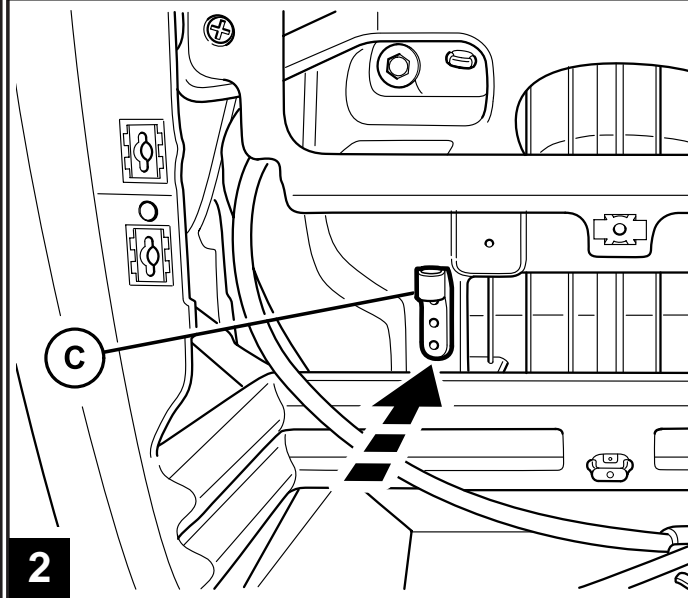
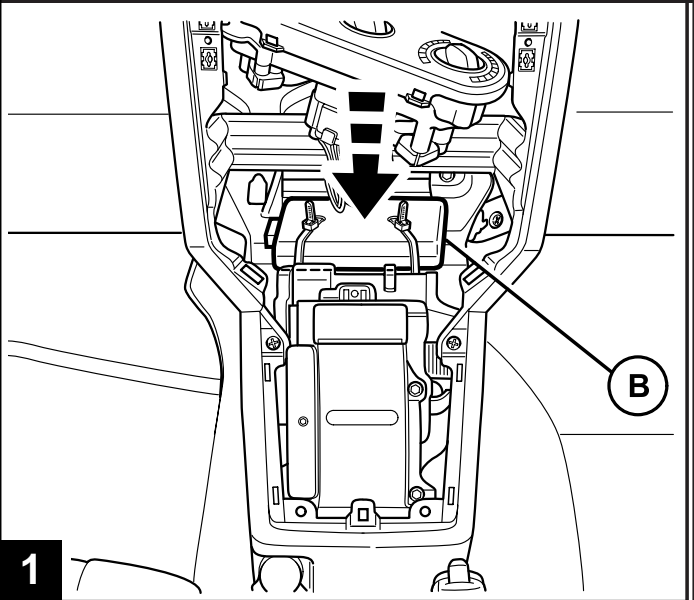
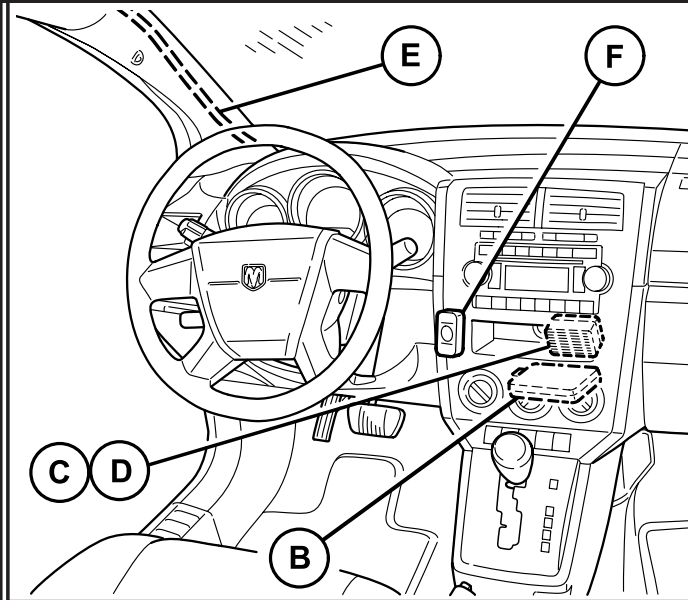

2005 ⇒ JEEP GRAND CHEROKEE

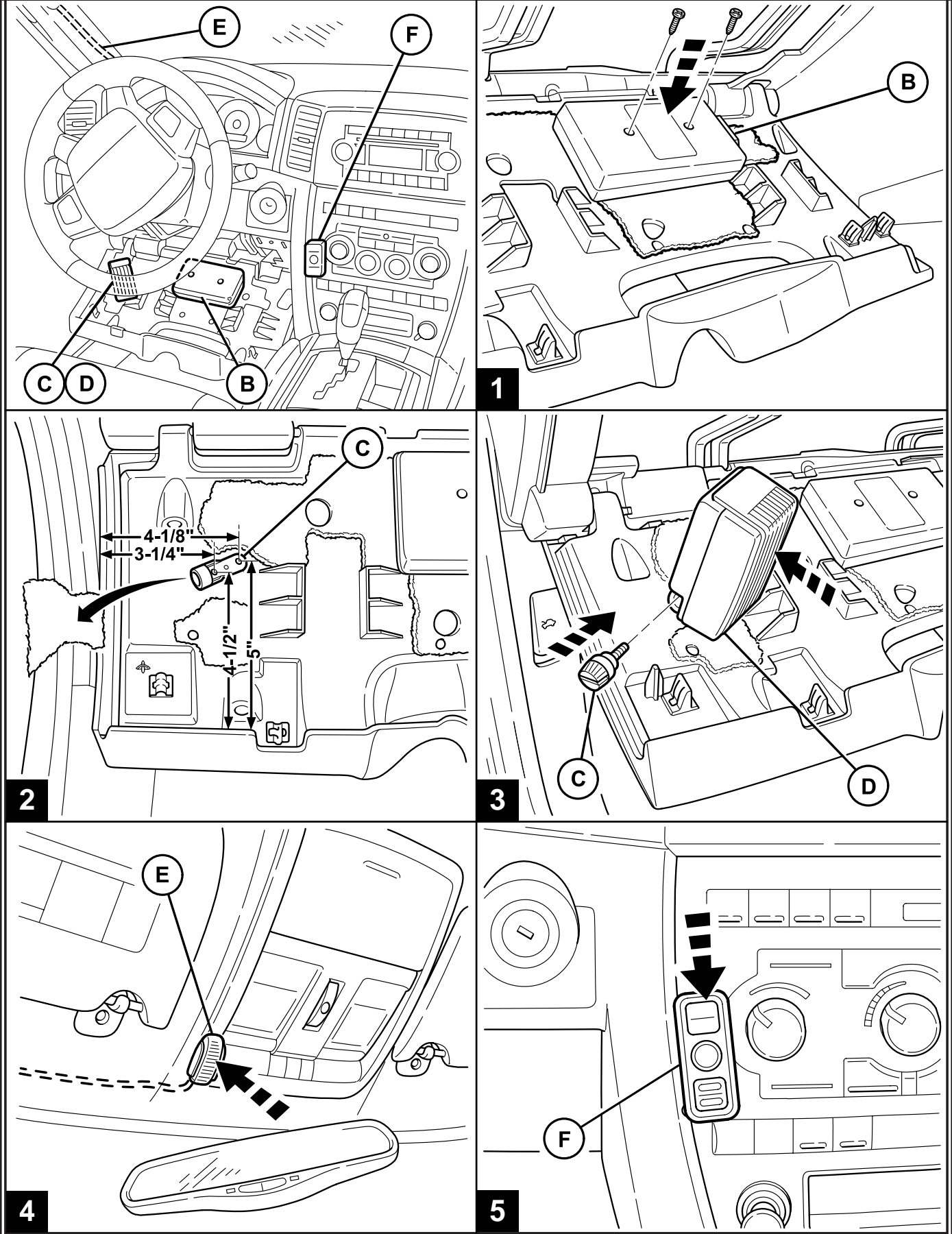

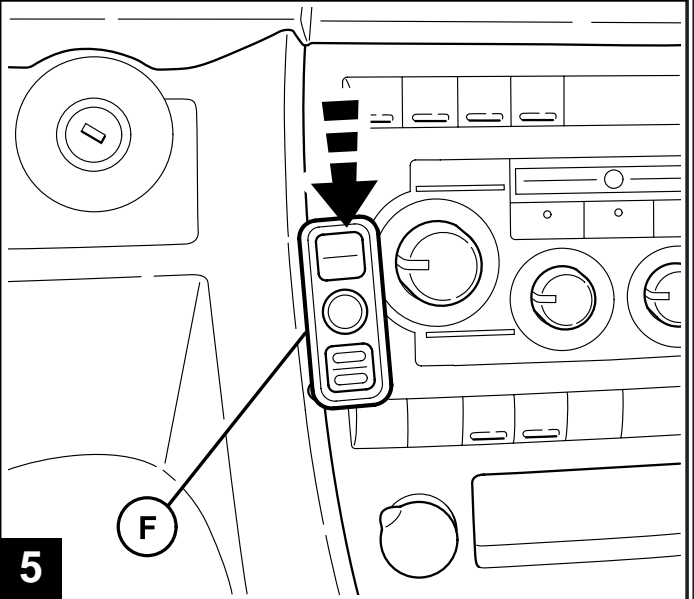
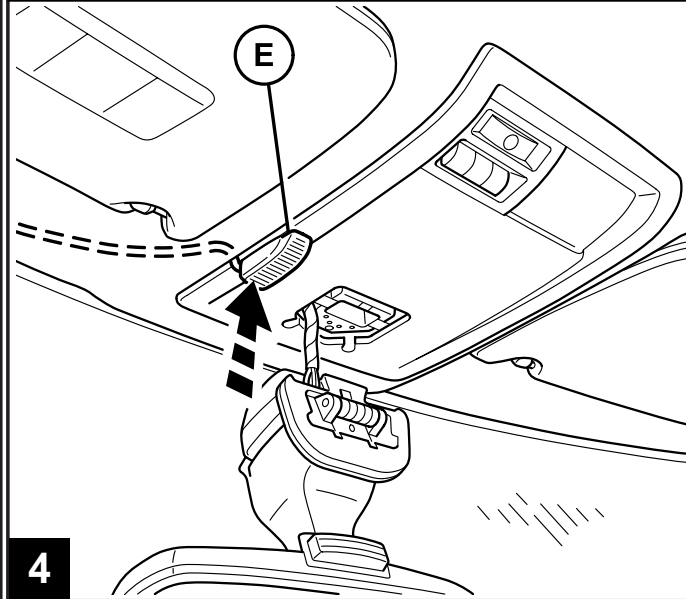
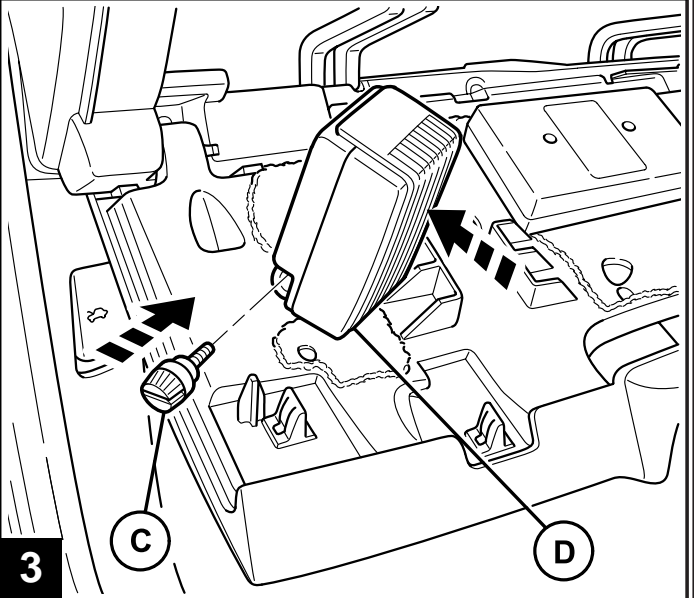
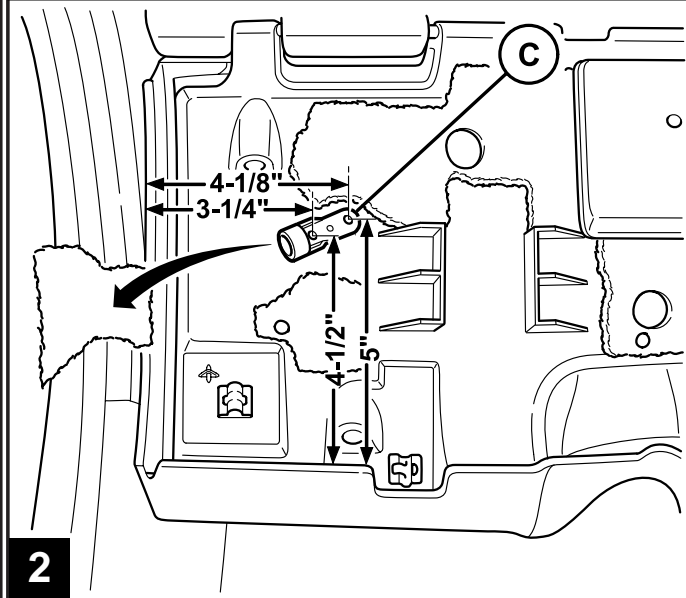
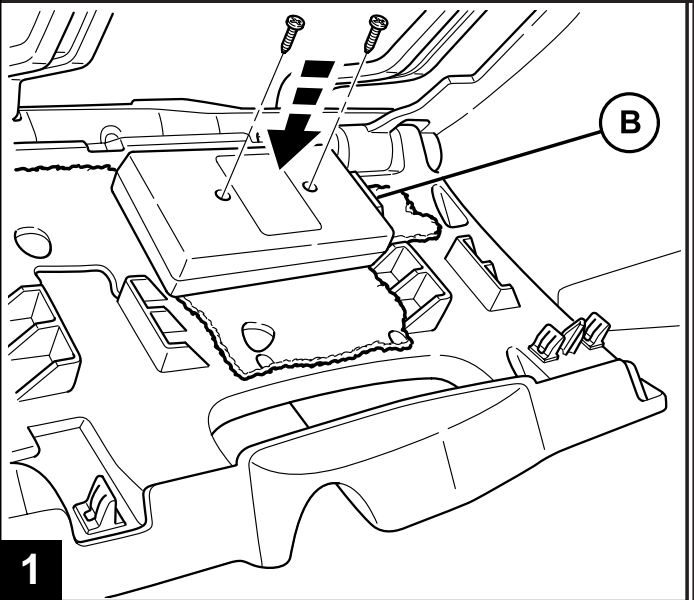
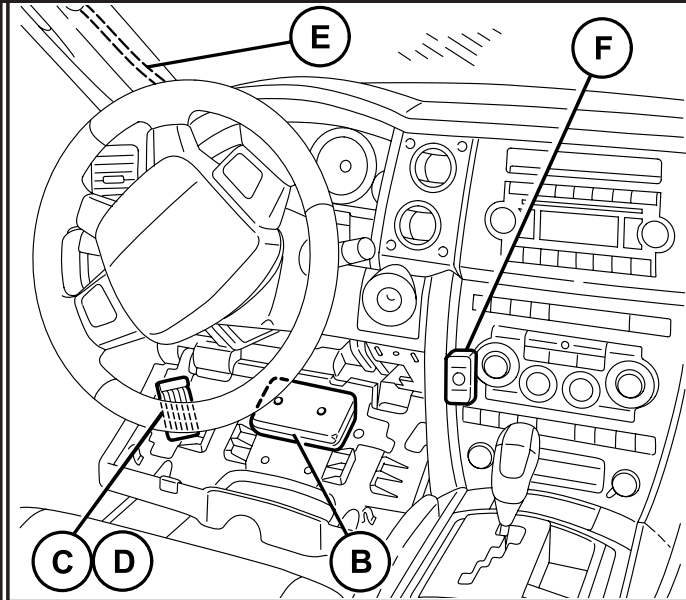

JEEP COMPASS

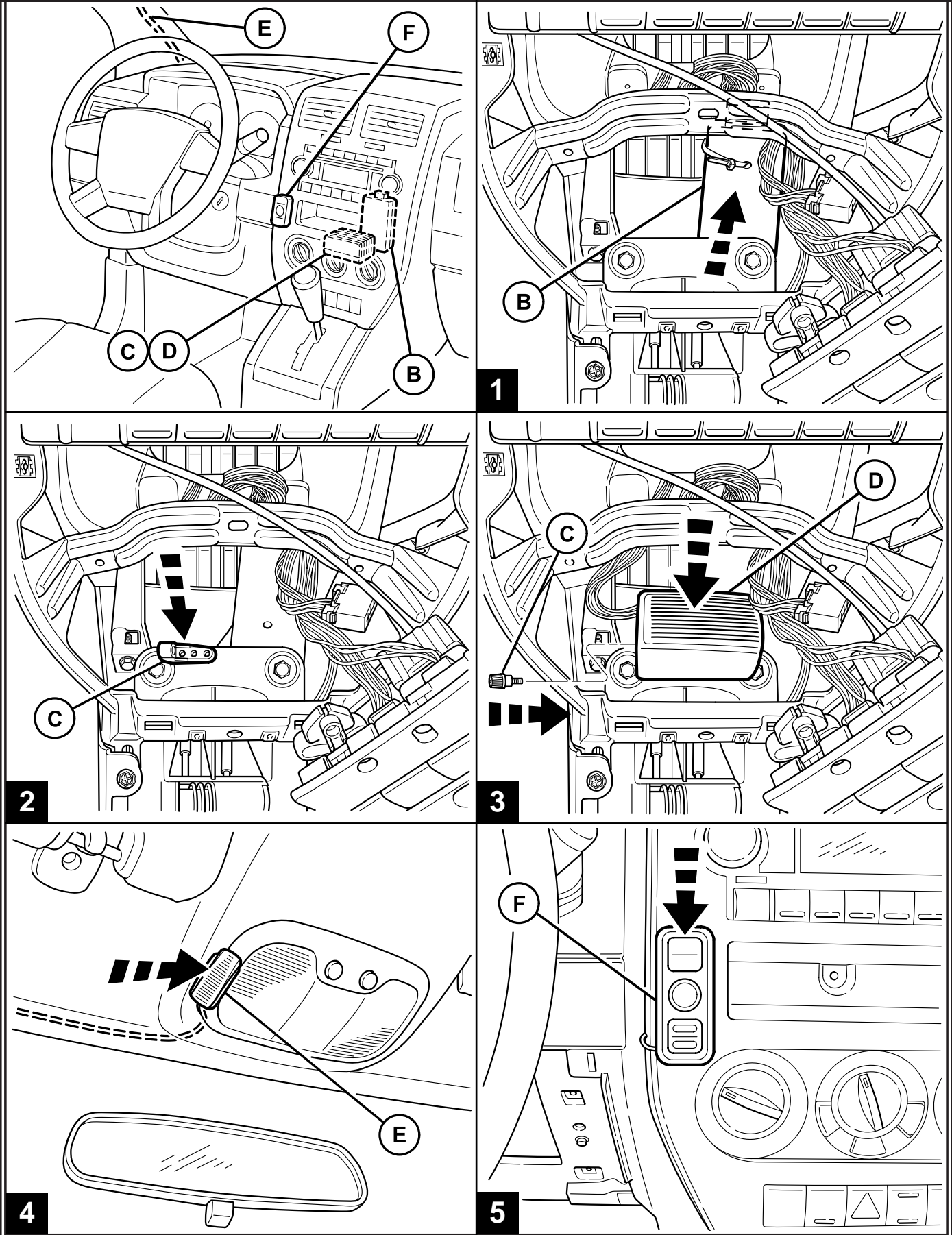

2002-05 CHRYSLER PT CRUISER

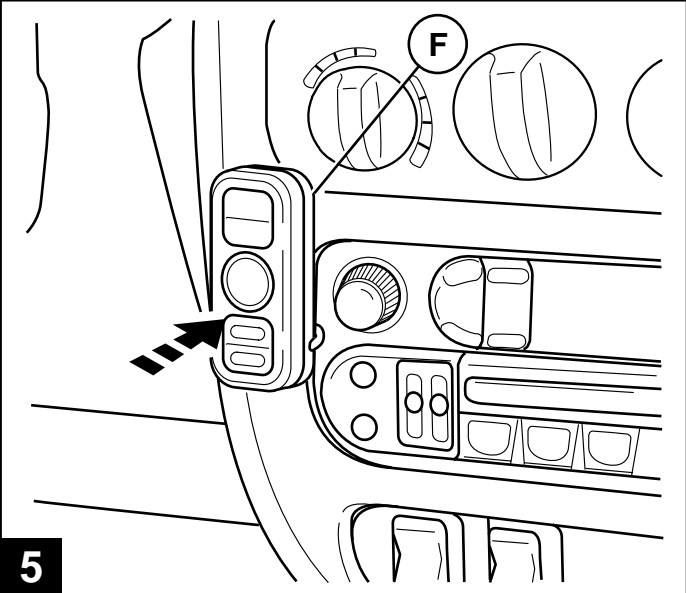
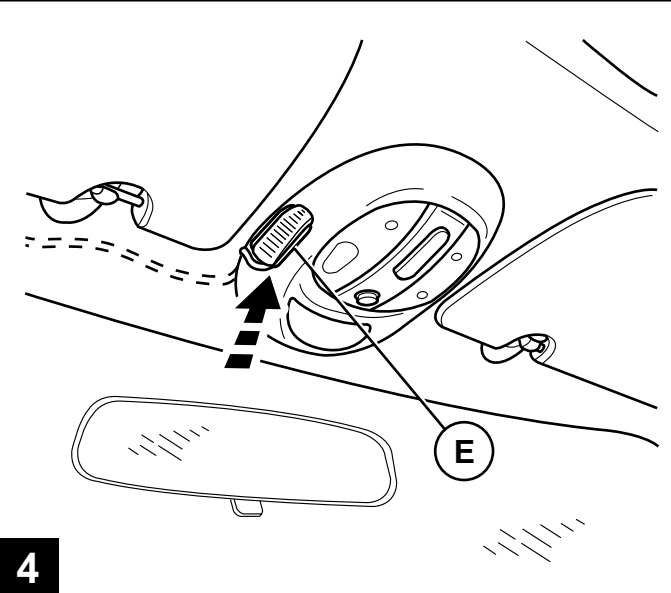
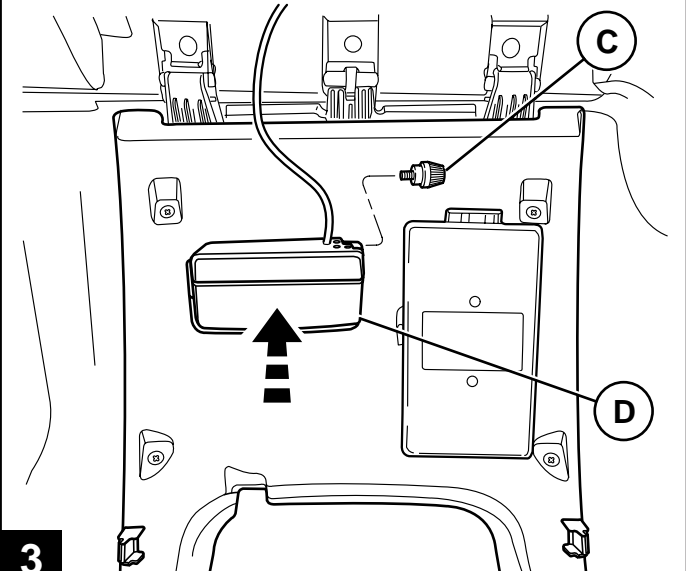
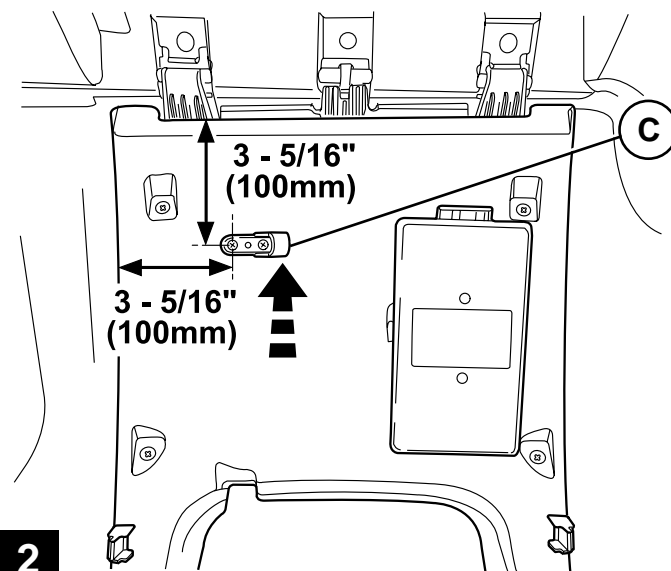
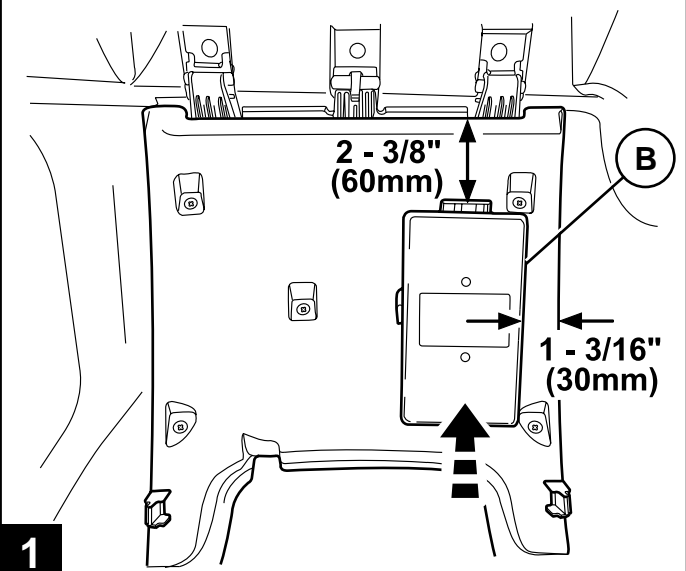
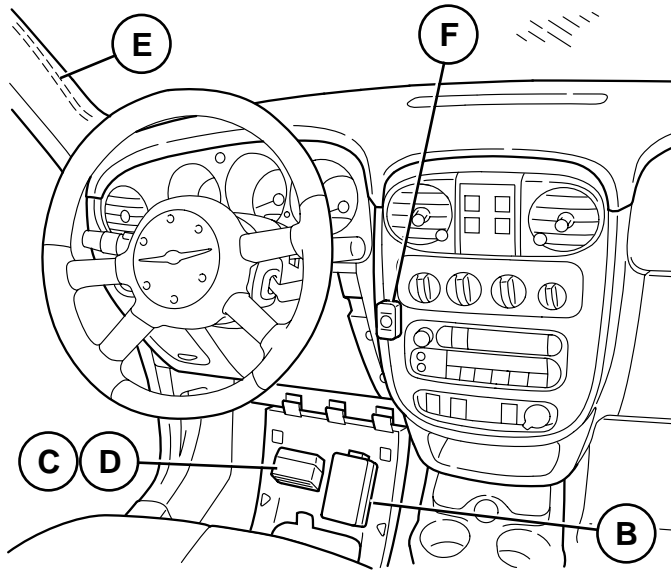

CHRYSLER 300M, CONCORDE / DODGE INTREPID

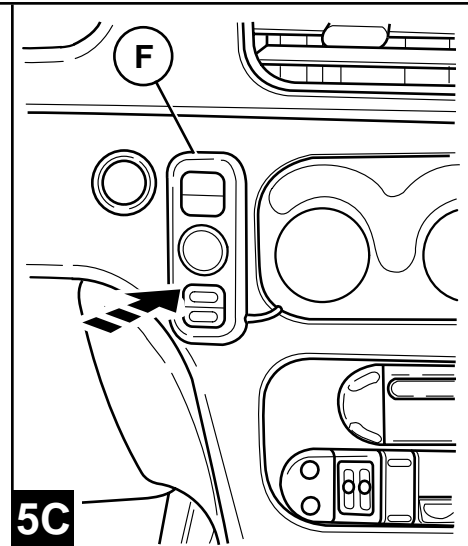
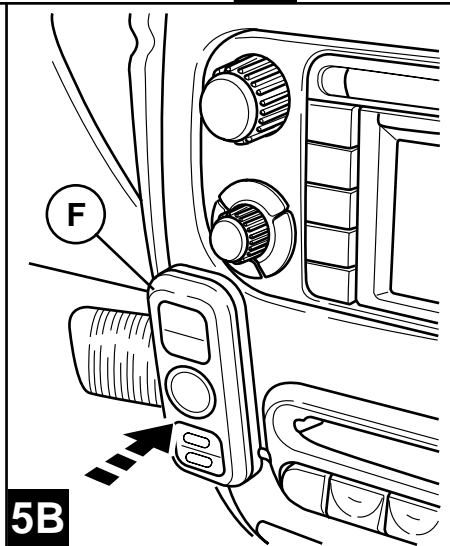
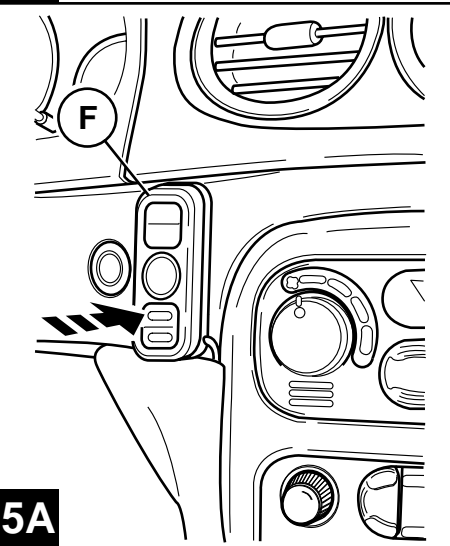
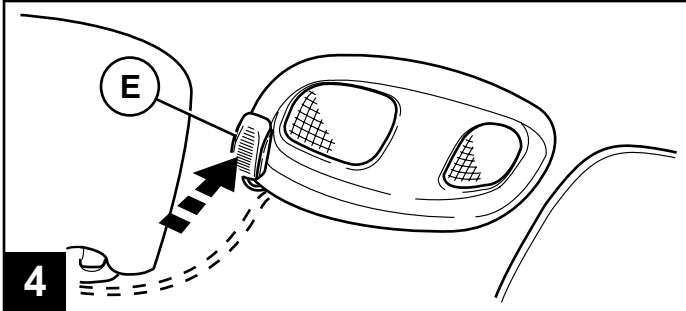
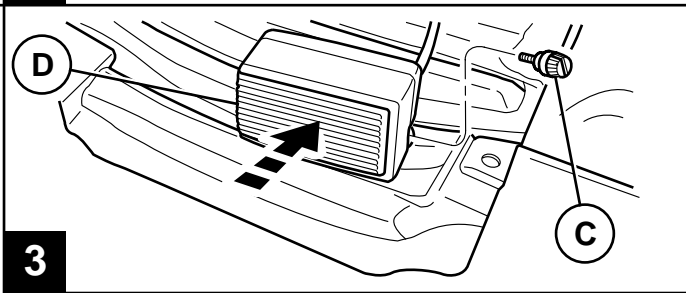
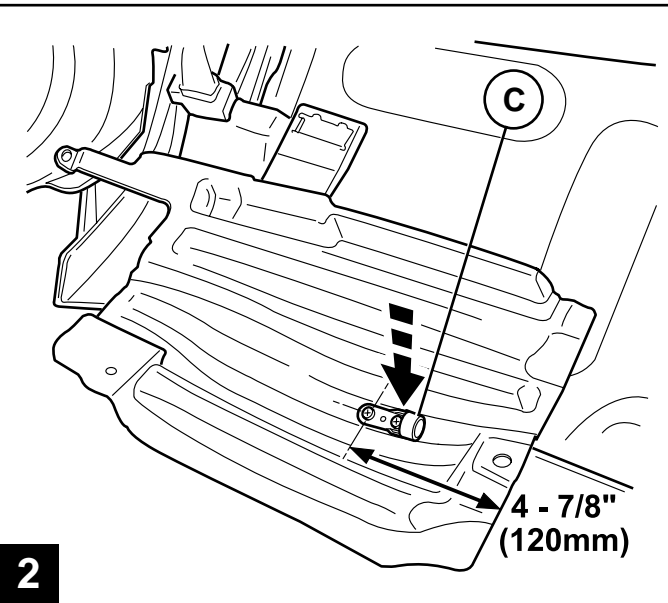
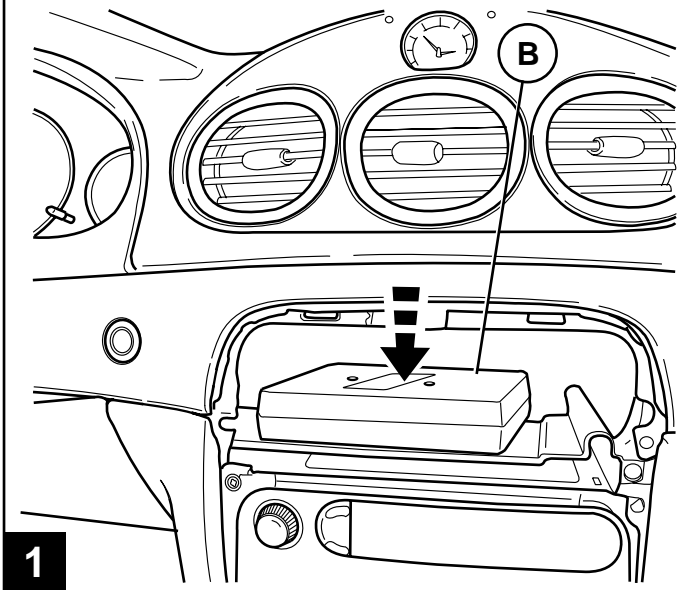
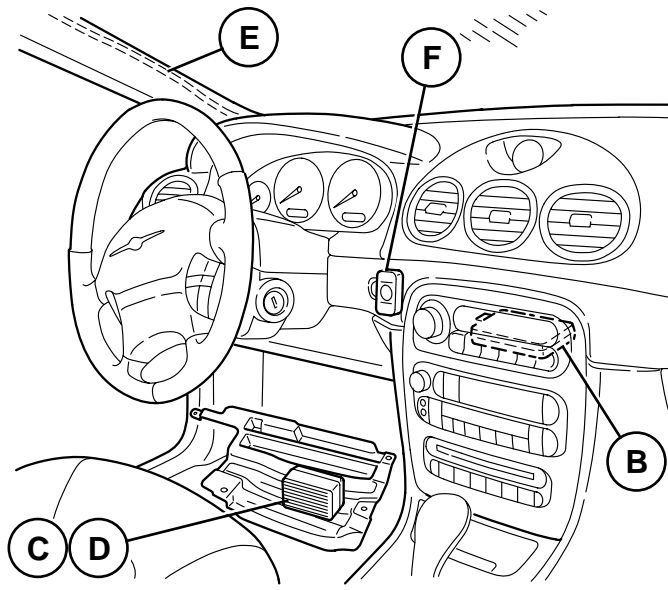

5A **300M**

5B **CONCORDE**

5C **INTREPID**

CHRYSLER PACIFICA

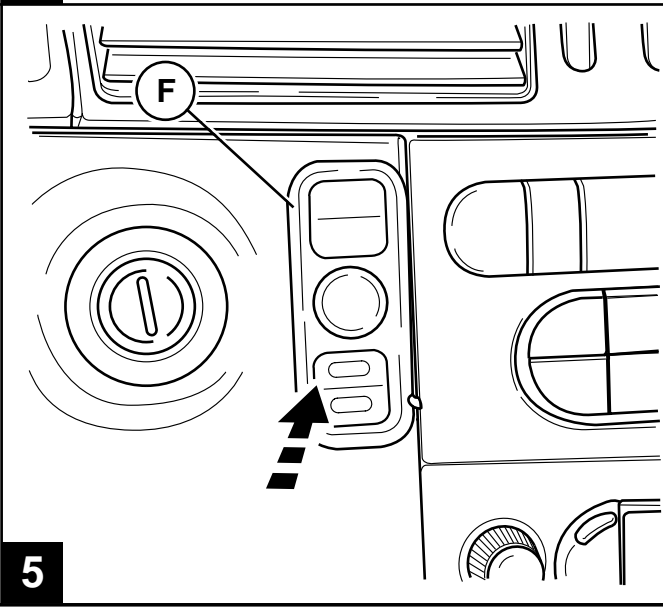
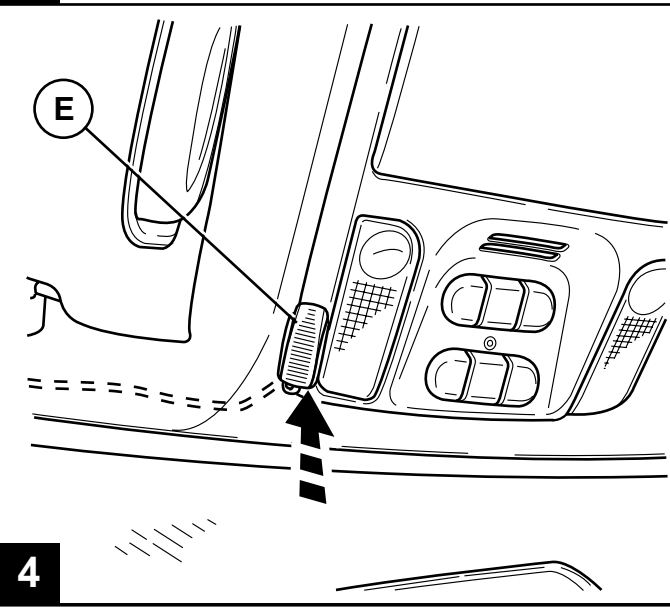
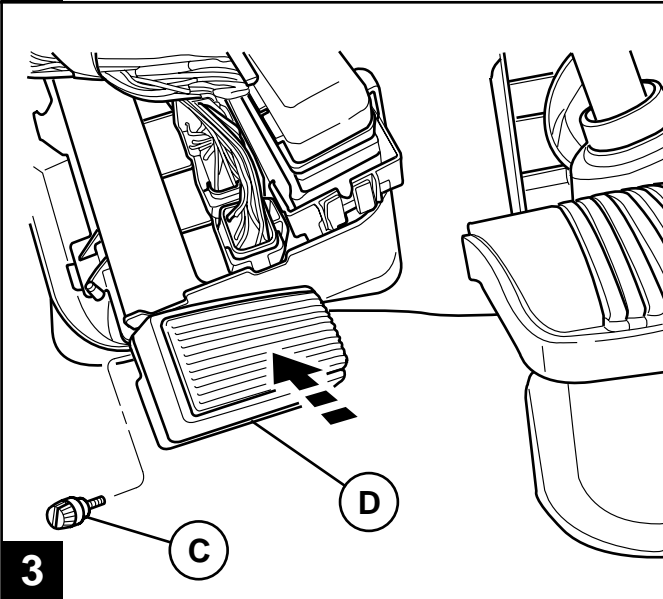
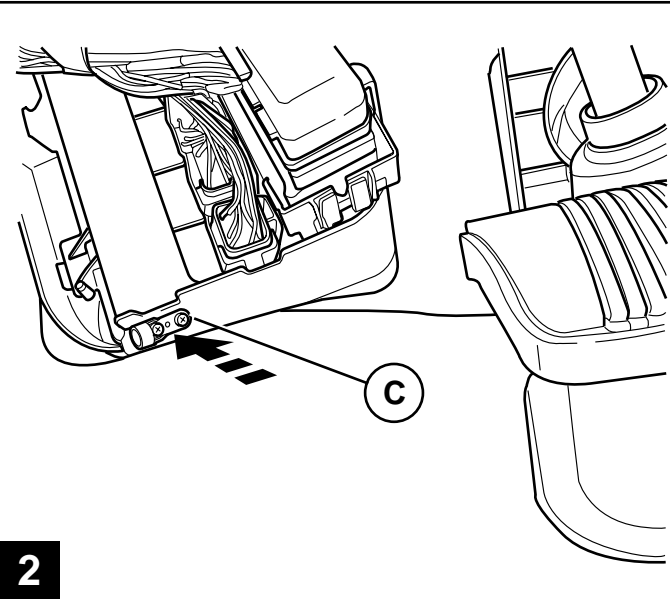
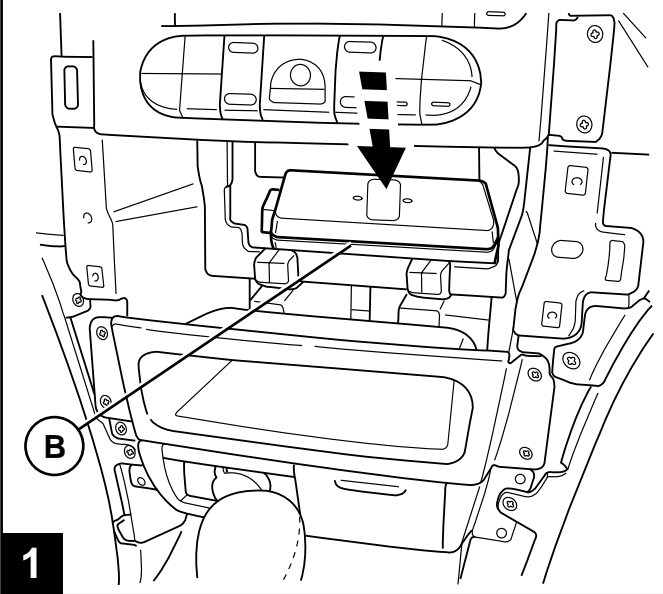
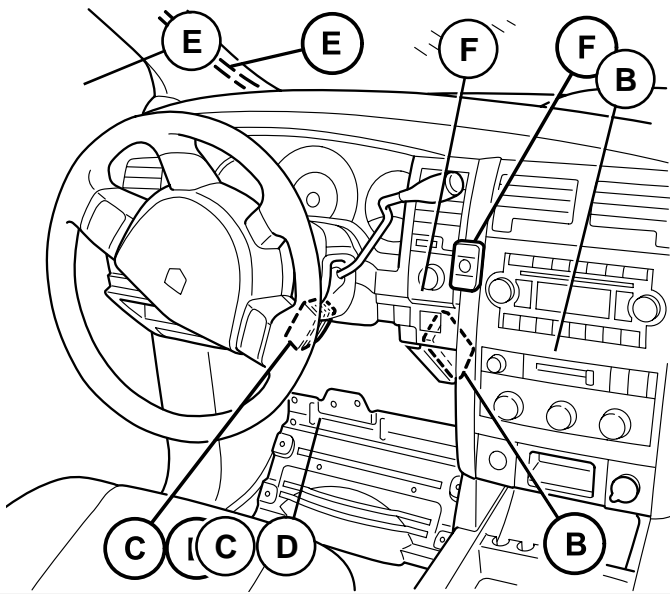

CHRYSLER SEBRING SEDAN / DODGE STRATUS

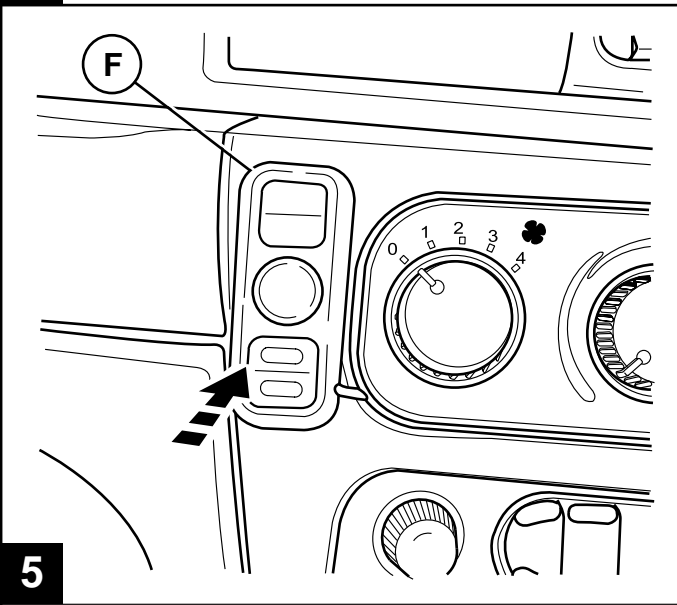
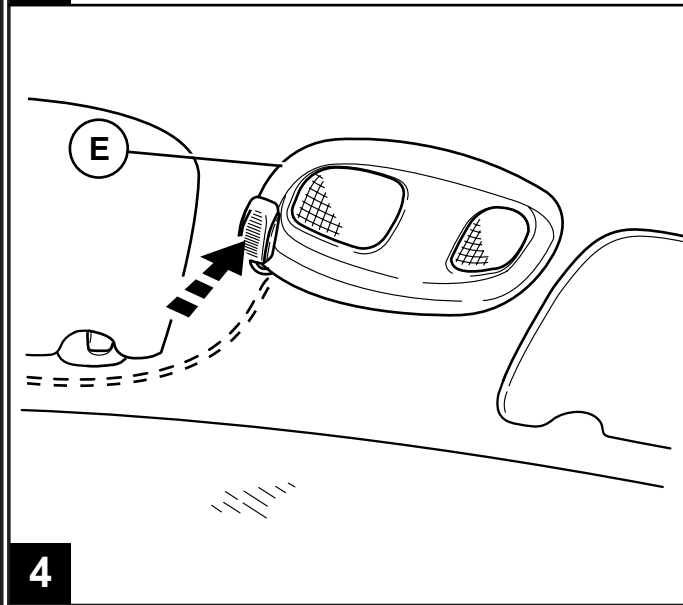
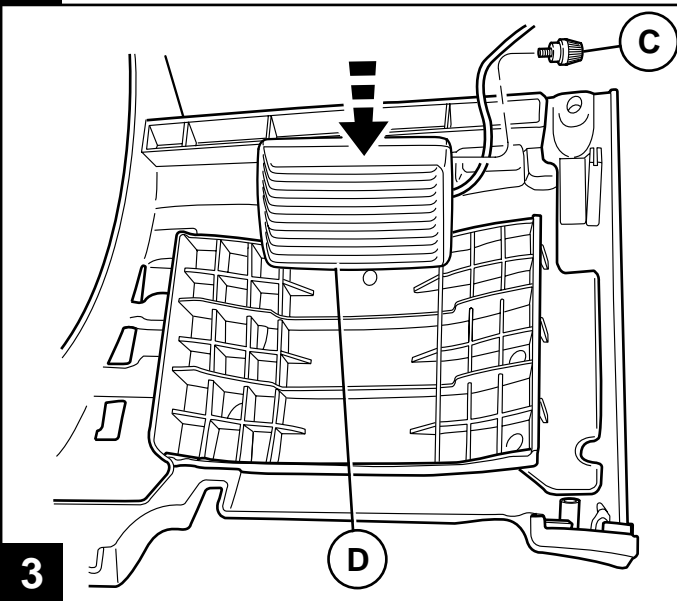
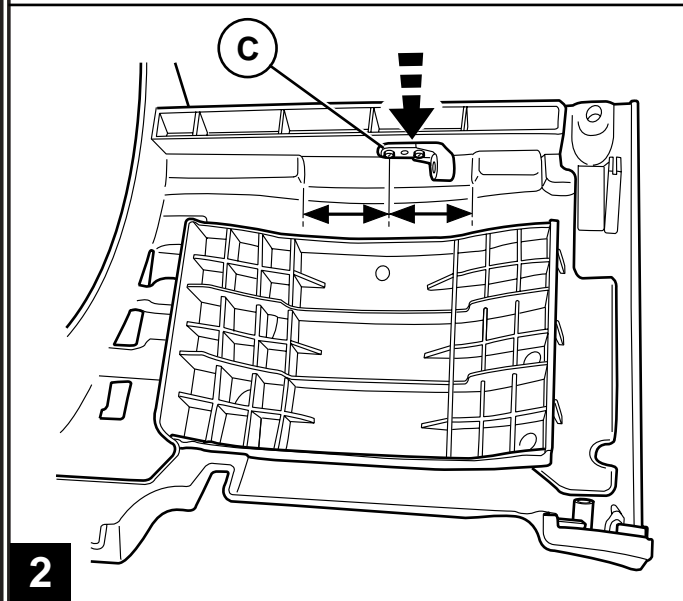
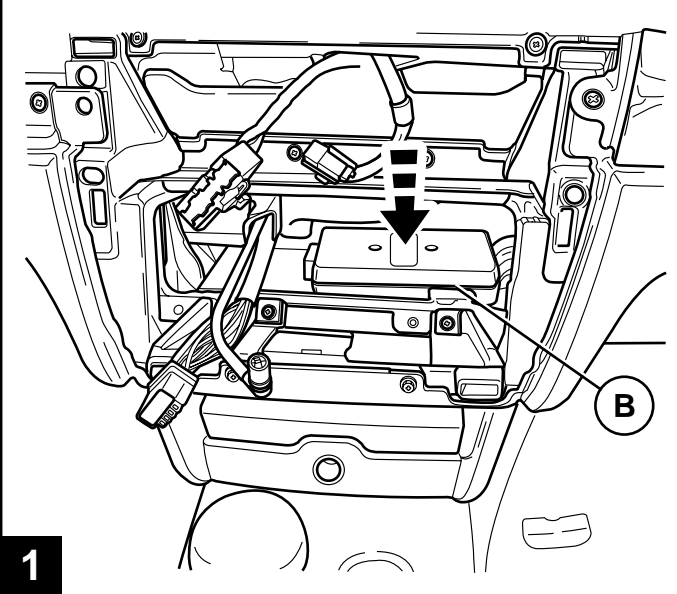
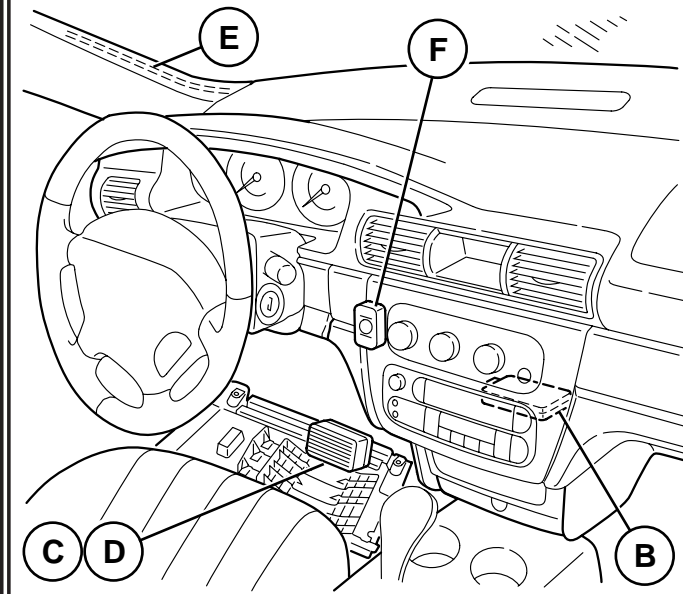

CHRYSLER TOWN & COUNTRY / DODGE CARAVAN

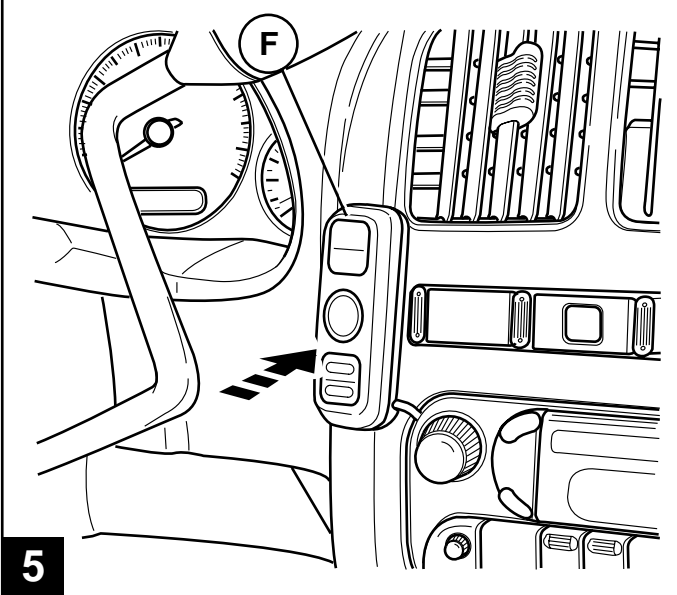
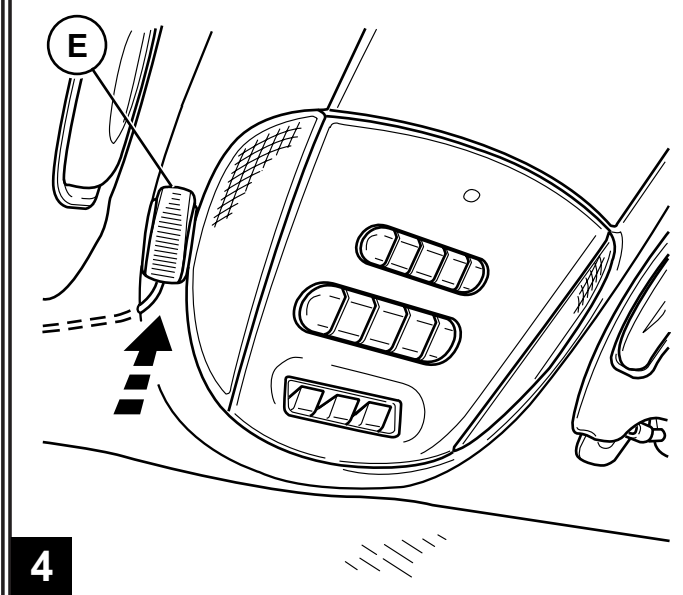
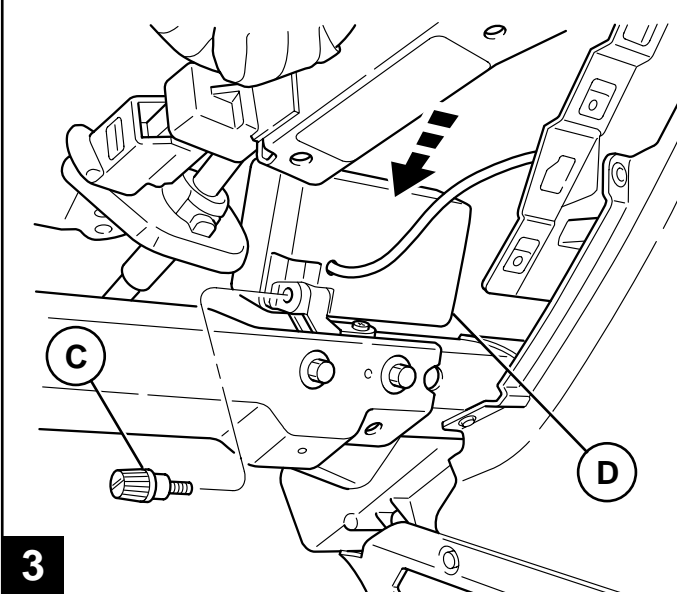
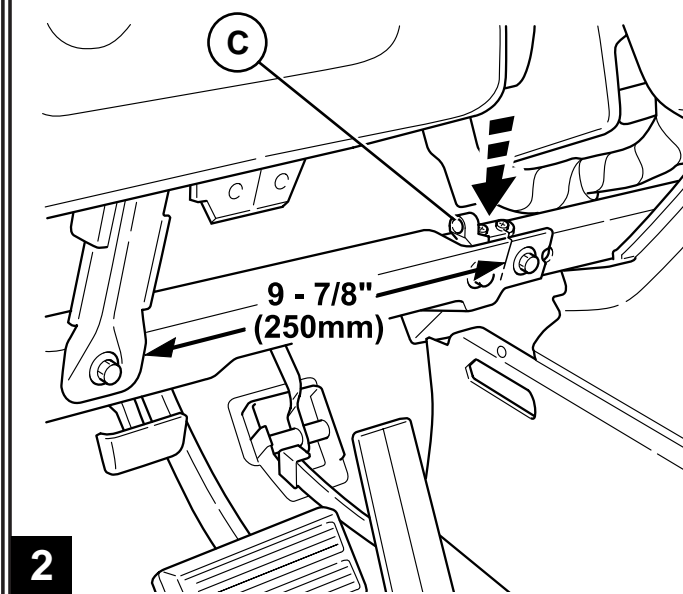
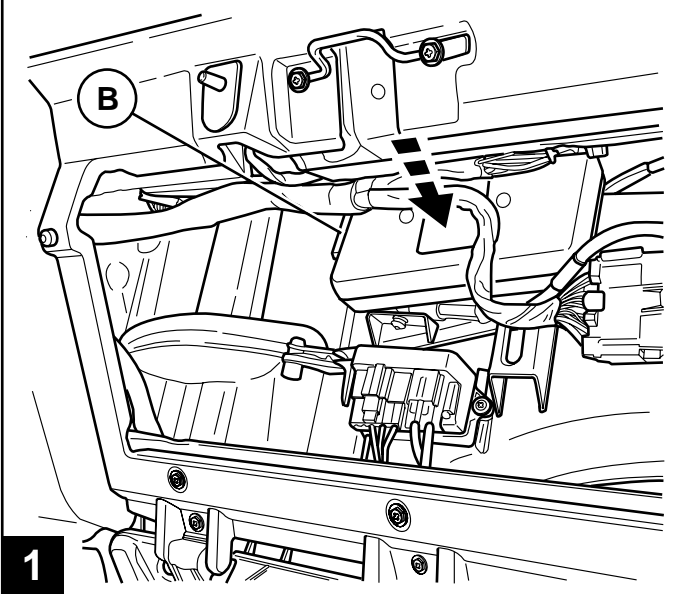
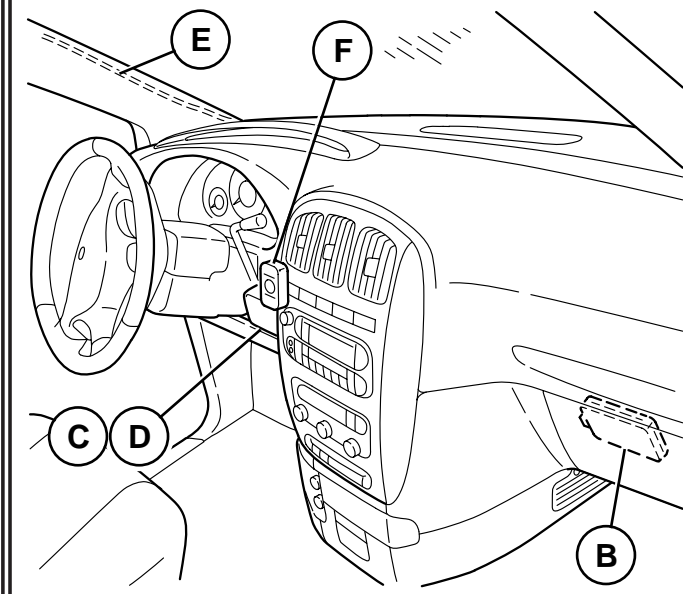

2002-03 DODGE DURANGO, 2002-04 DODGE DAKOTA

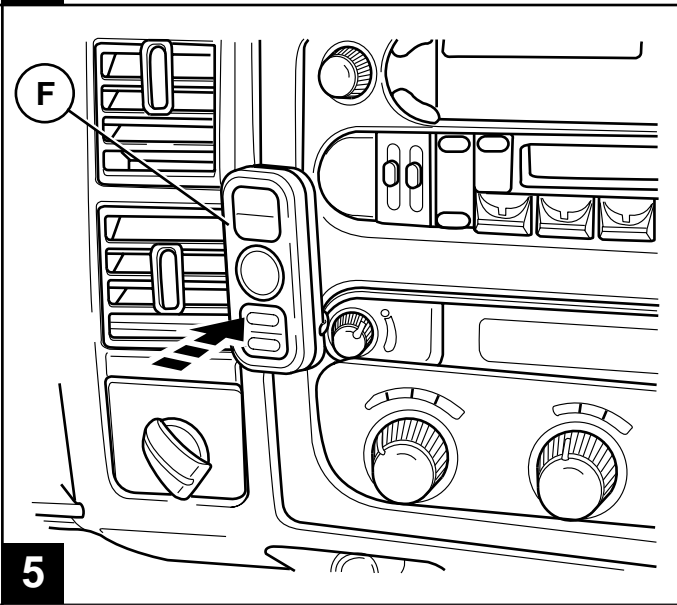
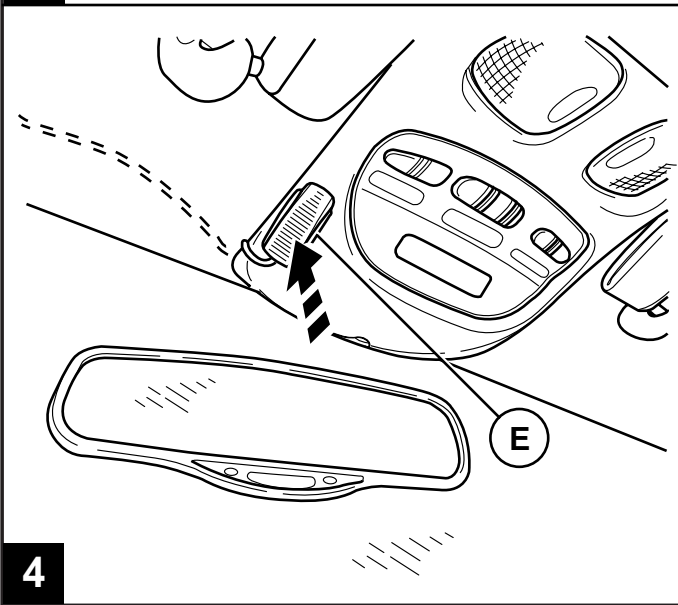
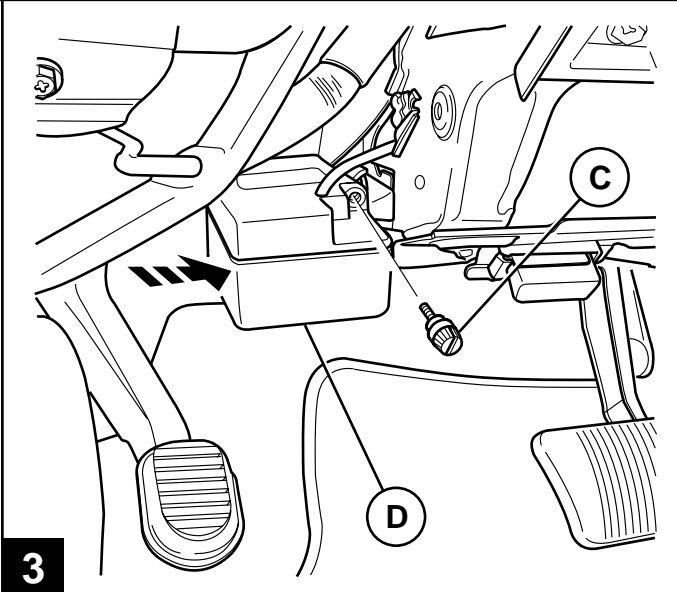
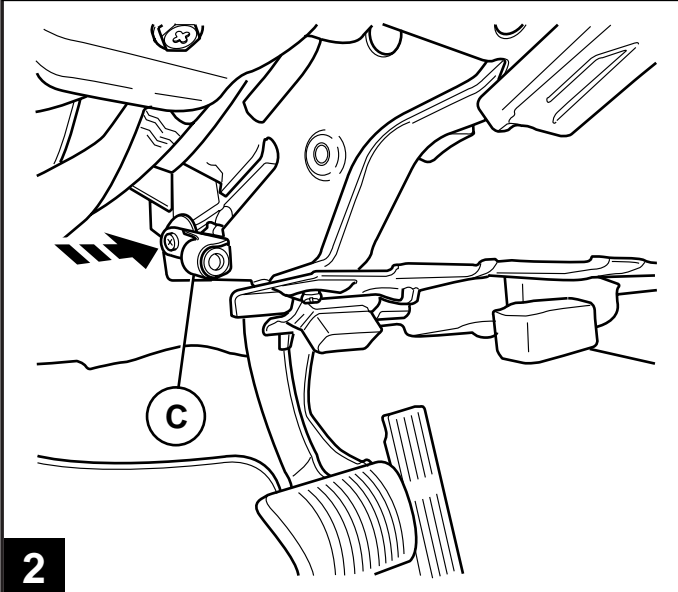
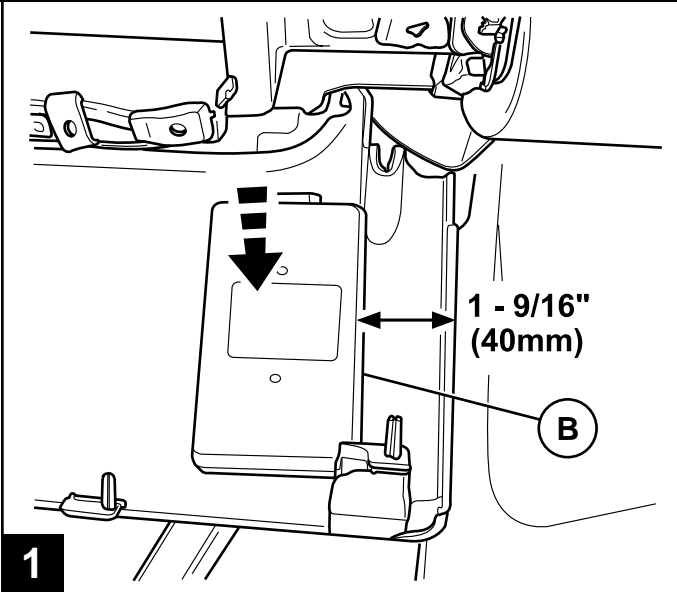
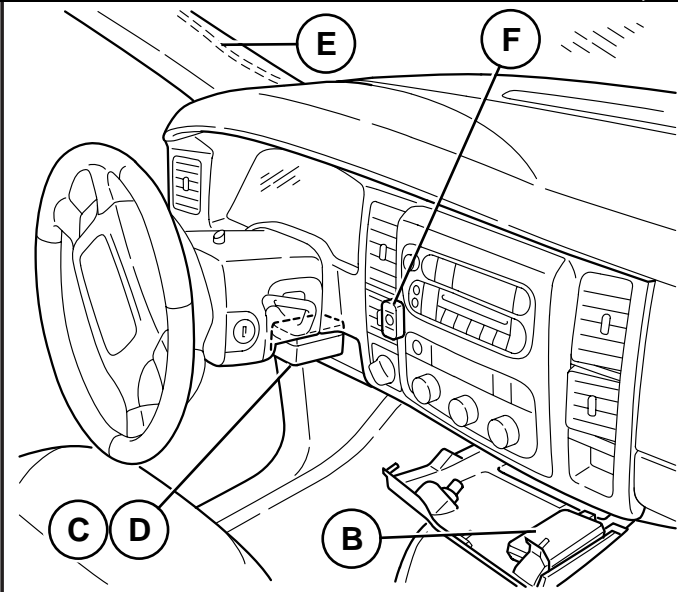

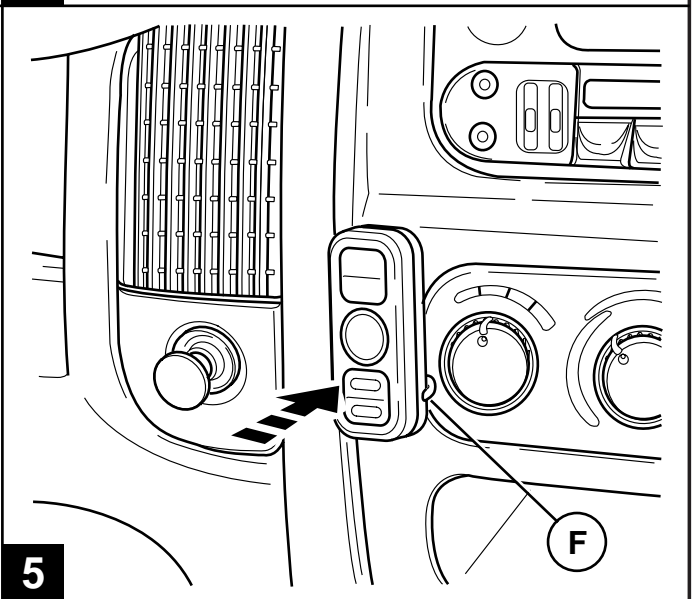
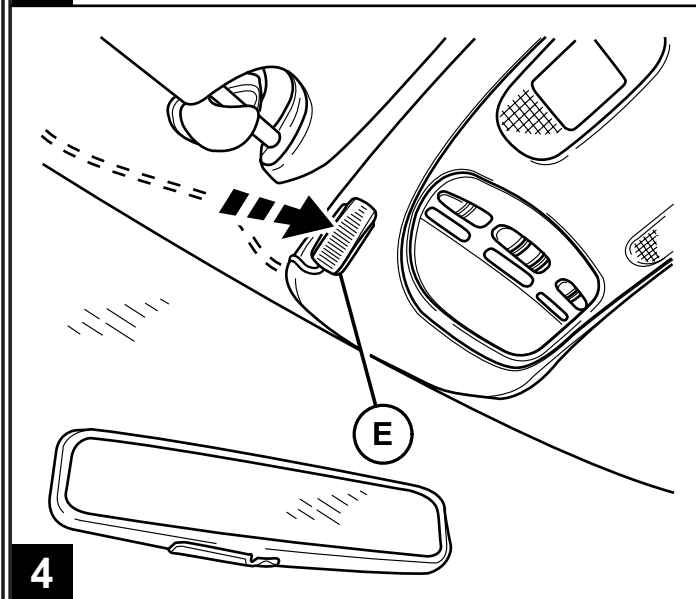
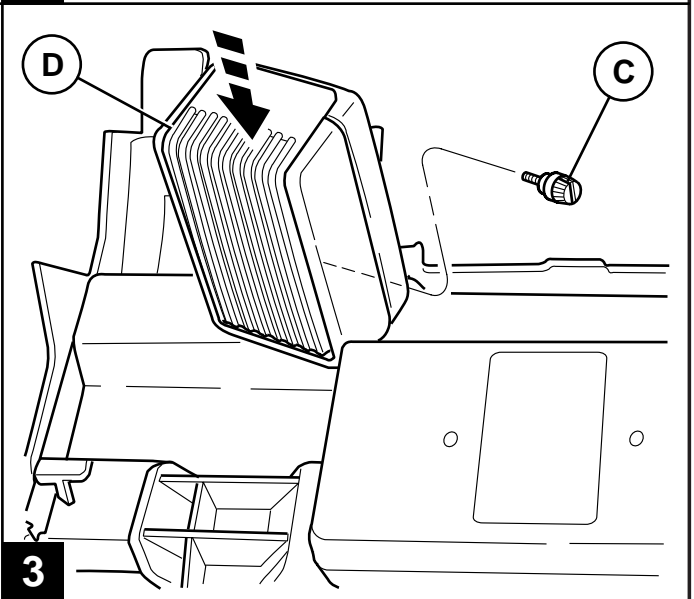
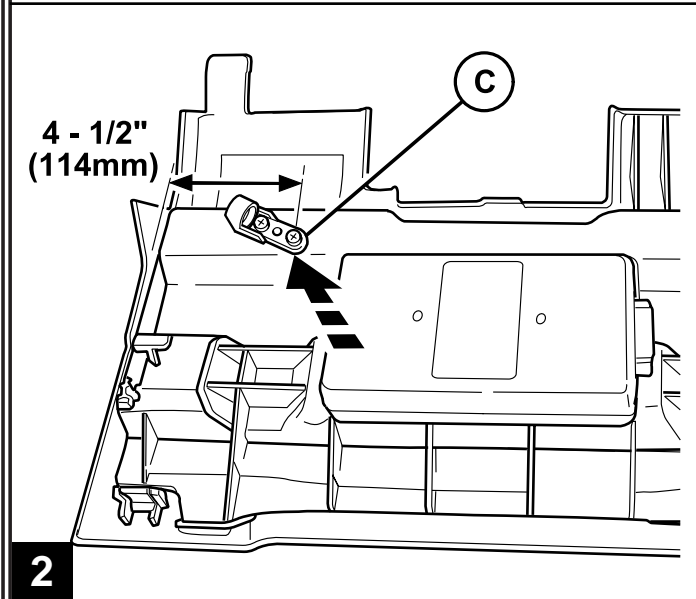
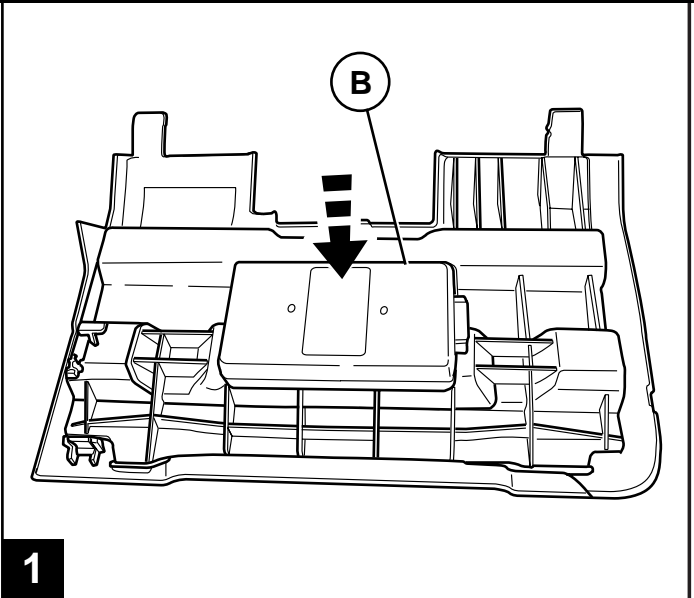
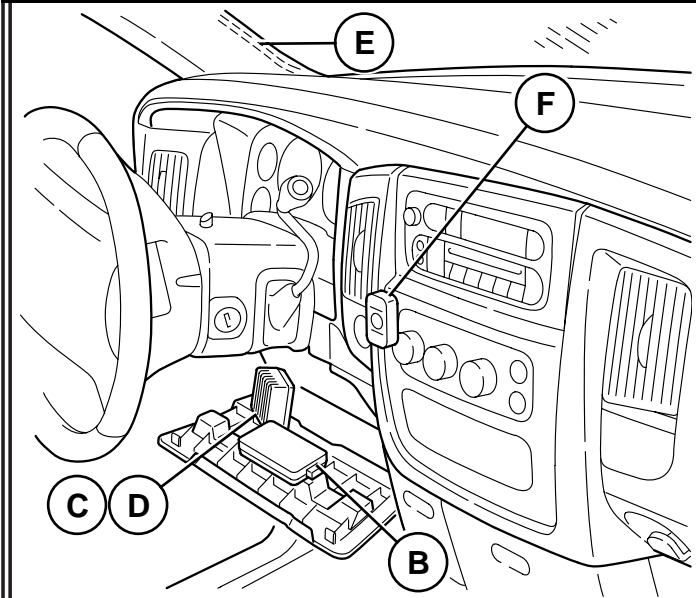

DODGE NEON

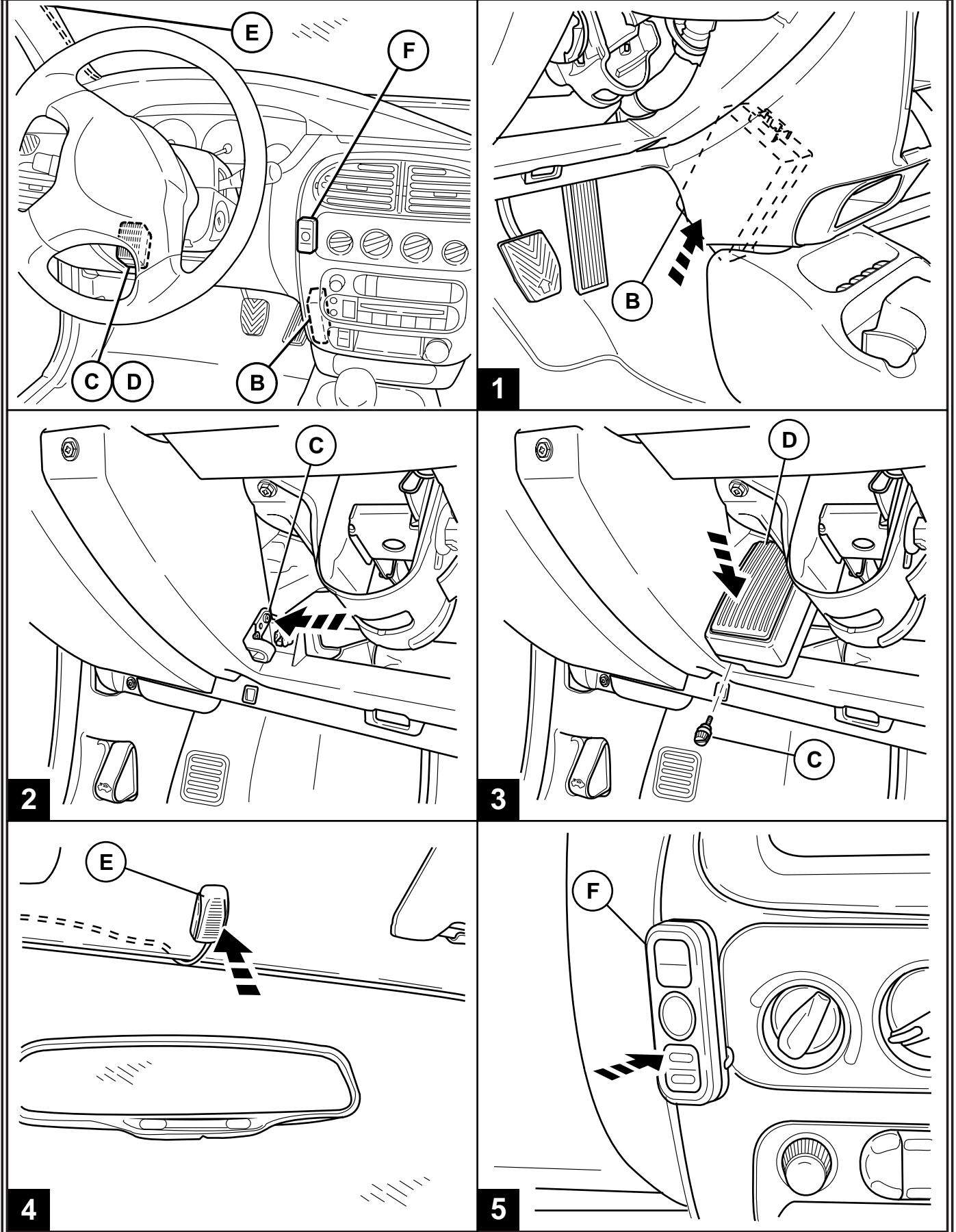

2002-04 JEEP GRAND CHEROKEE

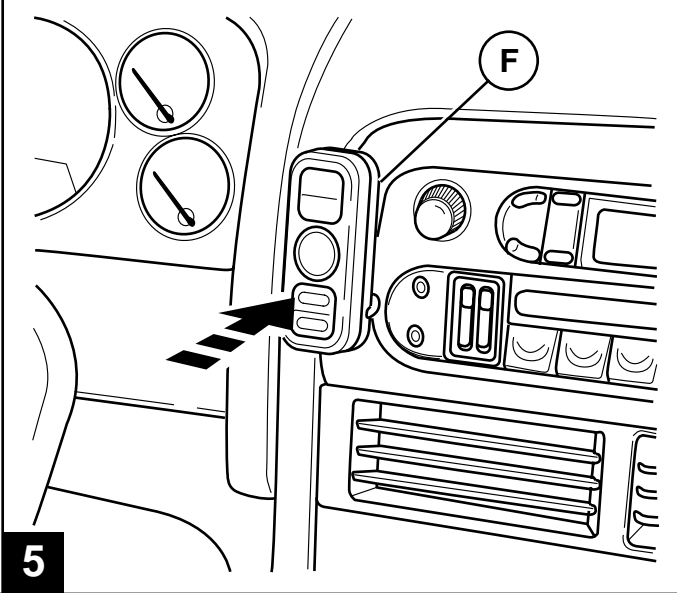
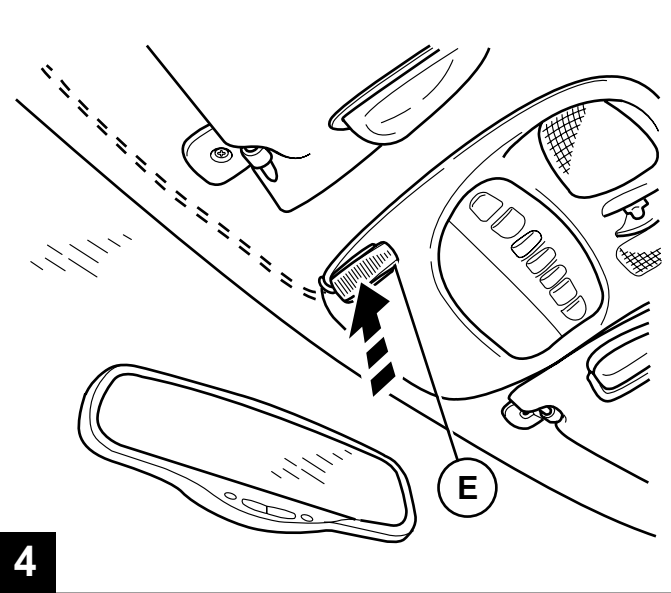
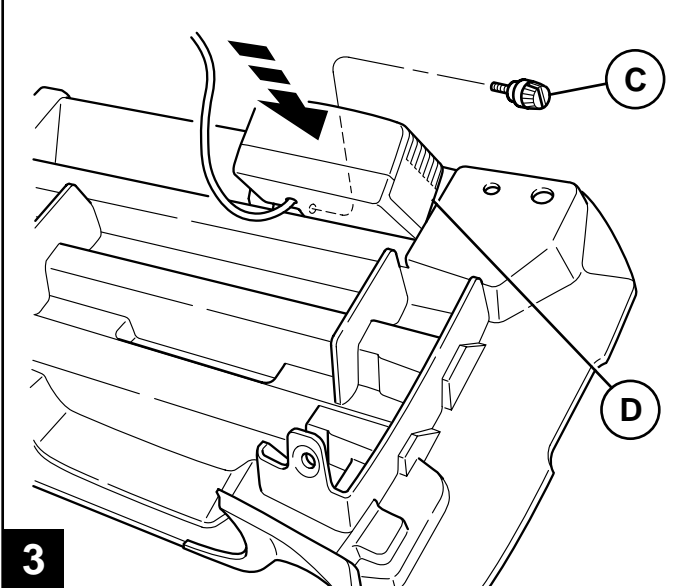
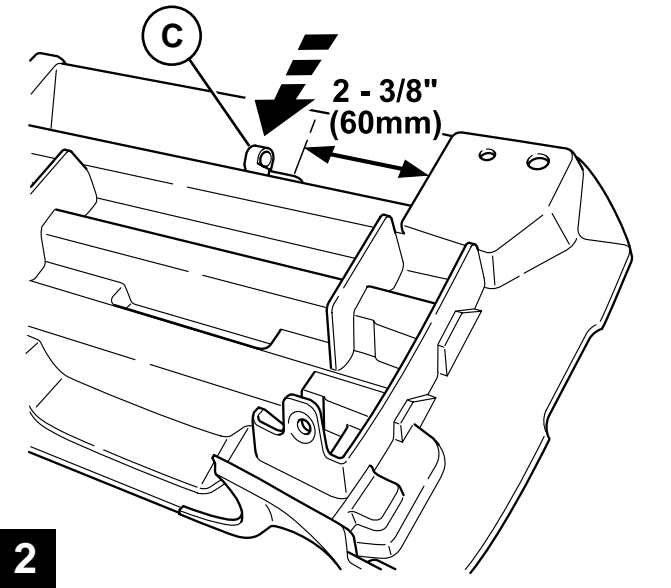
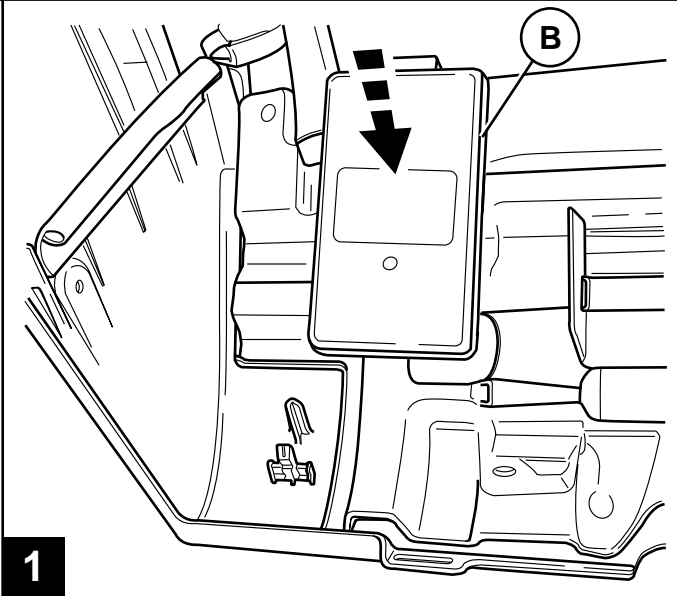
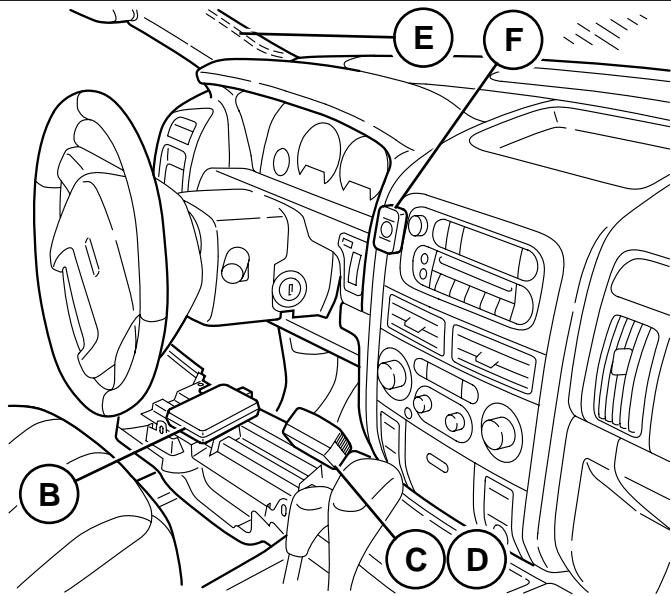

JEEP LIBERTY

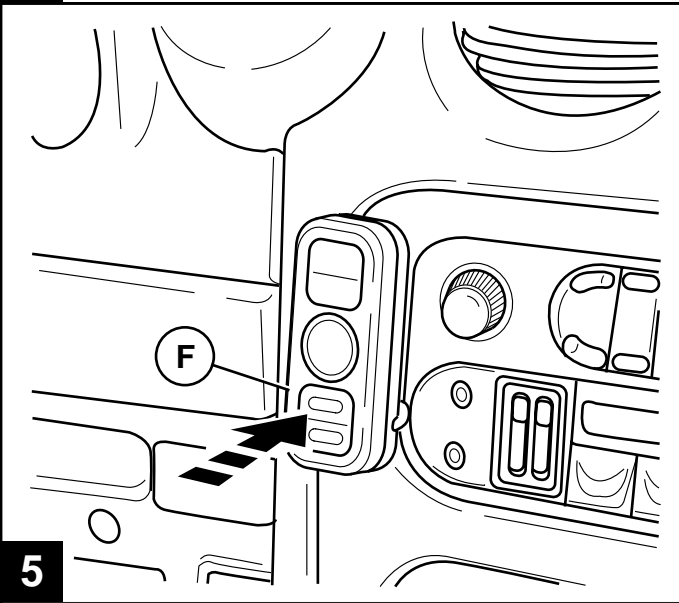
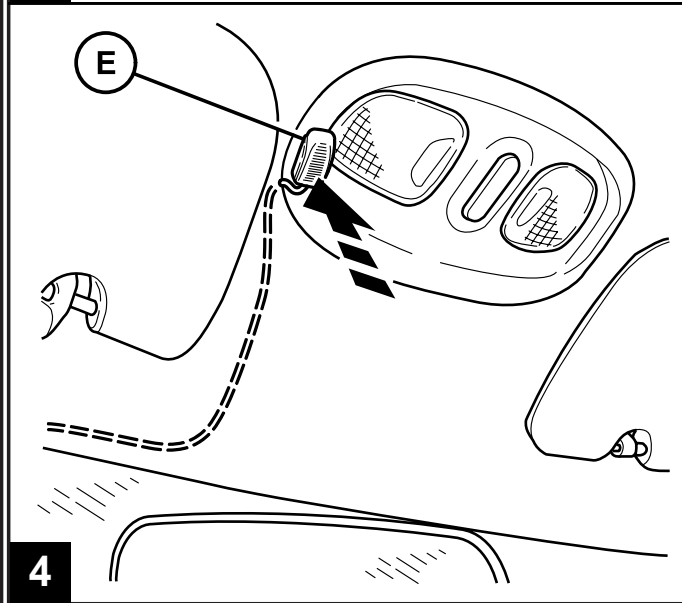
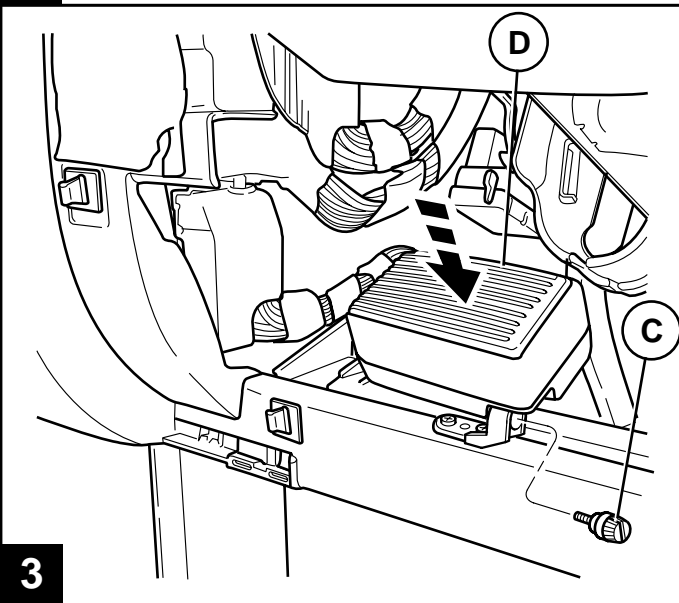
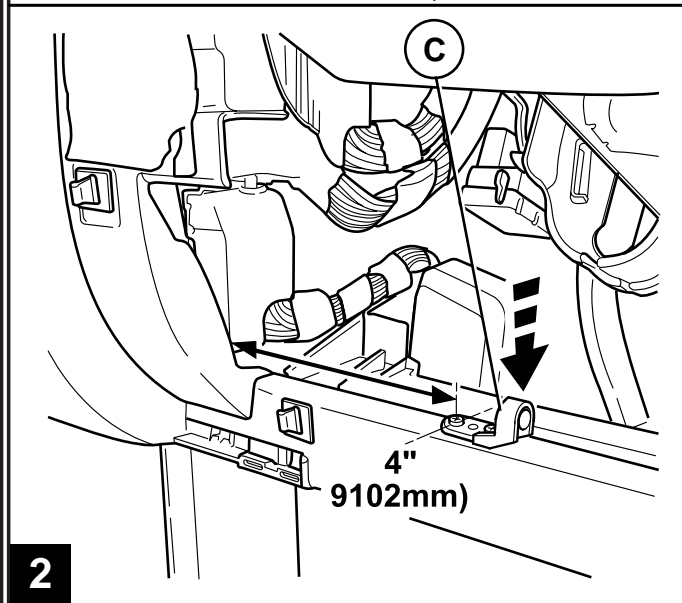
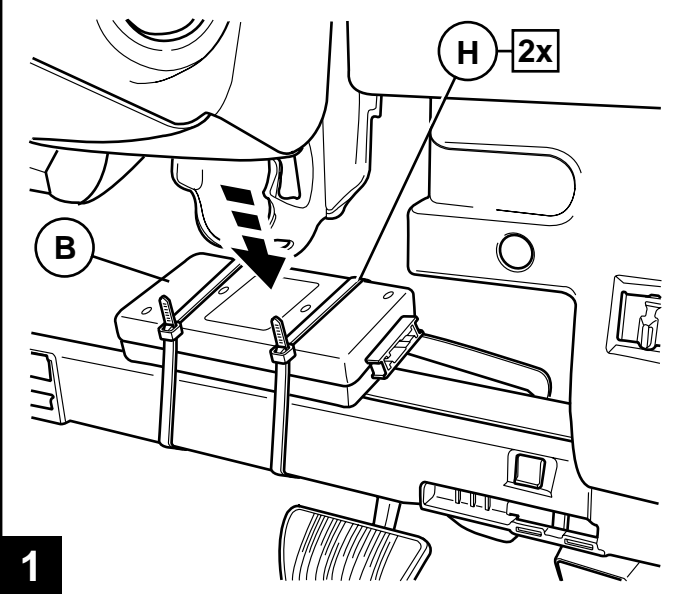
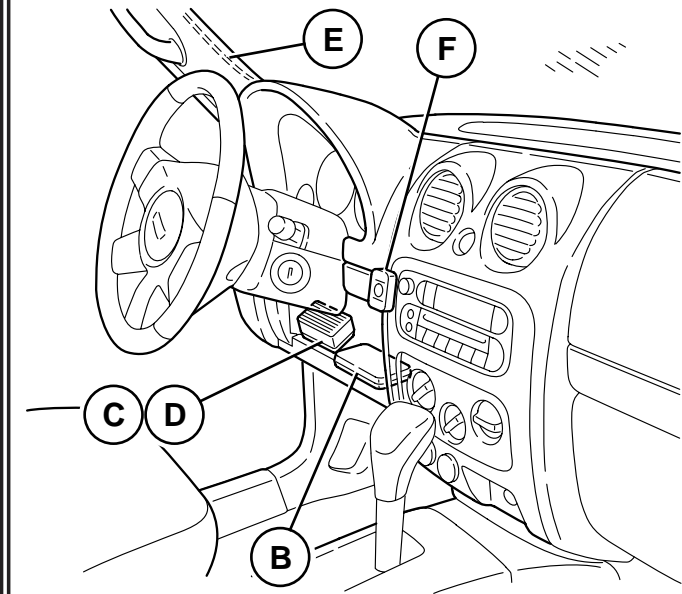

GB FUNCTIONAL CHECK PROCEDURE

1. Turn Ignition key to On position and turn radio on
 - Both amber light indicators on the UConnect control pad will illuminate momentarily (approx. 3 seconds)
2. Press UConnect Button on the control pad
 - System prompt will announce "UConnect Ready"
 - Radio audio will mute
 - Say "Dial", system should reply "Phone Not Available"
3. Push UConnect button again
 - System prompts with a dual tone beep
 - Radio will return to preset volume

Please follow included Owner's Manual for system operation.

E PROCEDIMIENTO DE VERIFICACIÓN FUNCIONAL

1. Gire la llave de Encendido hacia la posición ON y encienda el radio.
 - Ambos indicadores de luz color ámbar en el cojín de control UConnect se encenderán por un momento (3 segundos, aprox.)
2. Presione el botón UConnect en el cojín de control
 - Un aviso del sistema anunciará "UConnect Ready" (UConnect Listo)
 - El radio quedará en silencio
 - Diga "Dial" (Marcar). El sistema debe responder "Phone Not Available" (Teléfono no disponible).
3. Presione el botón UConnect nuevamente
 - SEI sistema responderá con un sonido de dos tonos
 - El volumen del radio regresará a su valor preestablecido

Para operar el sistema, siga las instrucciones que parecen en el Manual del Propietario.

F VÉRIFICATION DU FONCTIONNEMENT

1. Mettre le contact et allumer la radio
 - Les deux témoins jaunes du pavé de commande Uconnect s'allument brièvement (environ 3 secondes)
2. Appuyer sur le bouton Uconnect du pavé de commande
 - Un message vocal annonce << Uconnect Ready >>
 - La radio se met en sourdine
 - Dire : << Dial >>, le système doit répondre << Phone Not Available >>
3. Appuyer de nouveau sur le bouton UConnect
 - Le système produit un bip à double tonalité
 - La radio repasse au volume pré réglé.

Voir les instructions d'utilisation dans le manuel de l'appareil.