

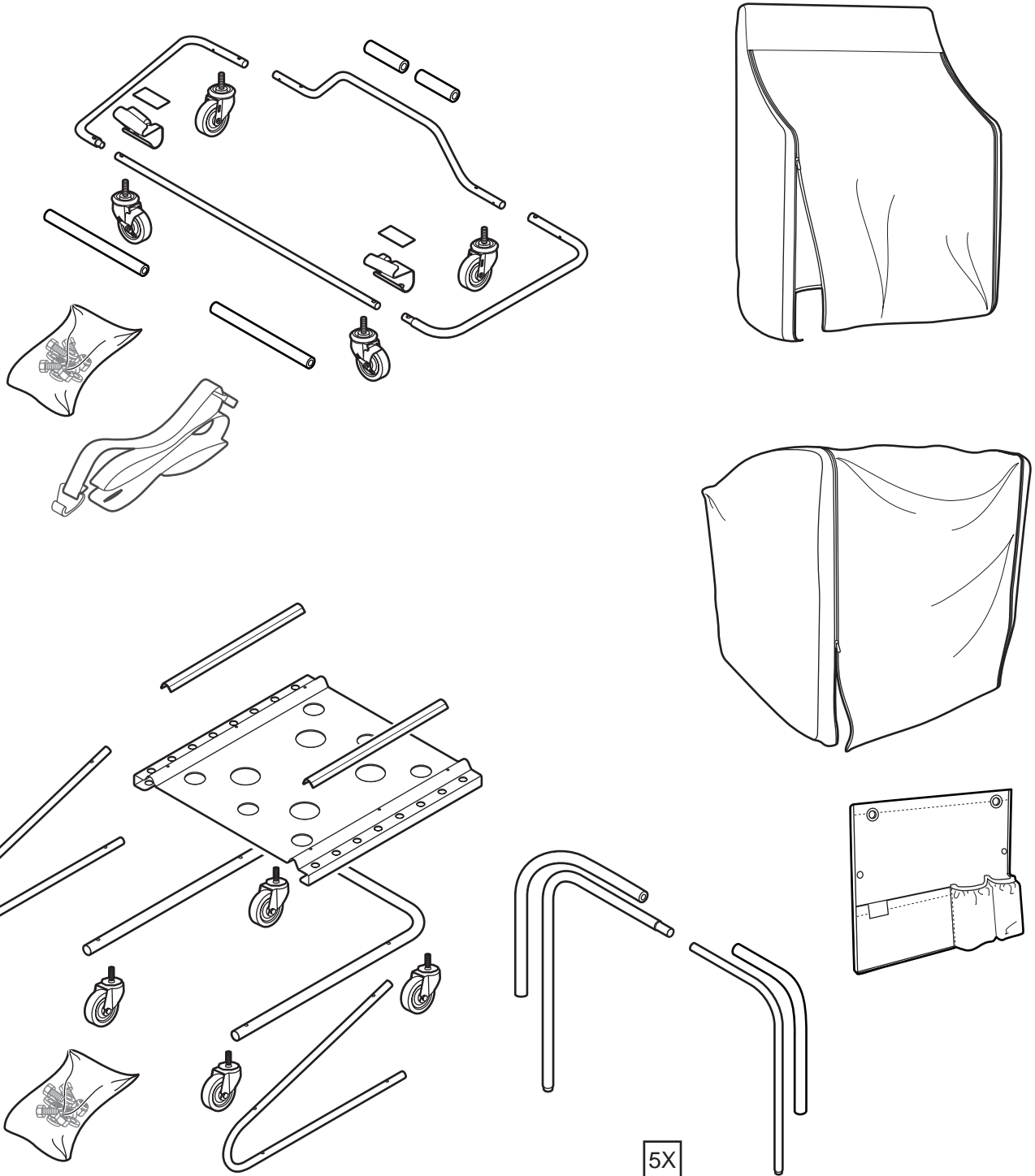

JEEP WRANGLER

Front Door/Hardtop Storage System*



* Storage Caddy – Holds two (2) Front Doors Only with two (2) Sun Top Panels and No Rear Doors

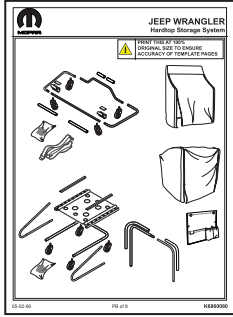

K6860080

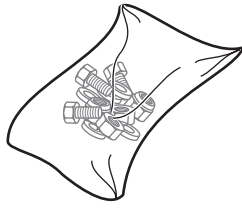

Top Cart

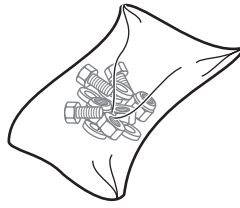

Door Cart

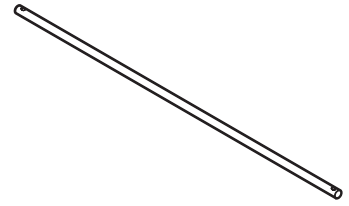

A 1X

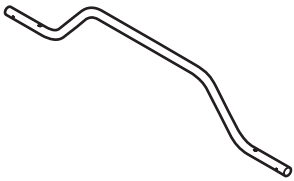

B 1X

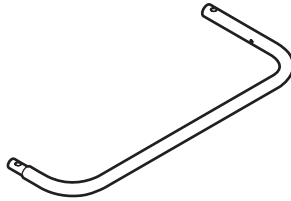

C 2X

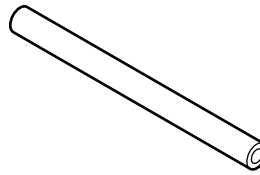

D 12X

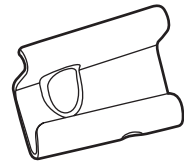

E 1X

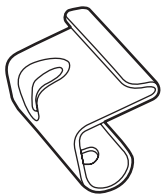

F 1X

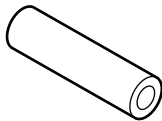

G 2X

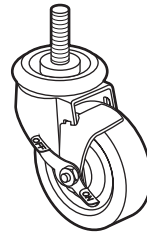

H 2X

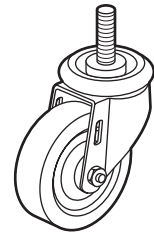

I 2X

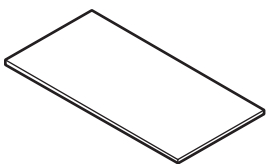

J 2X



K 5X

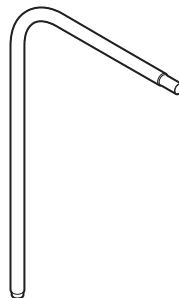

L 5X

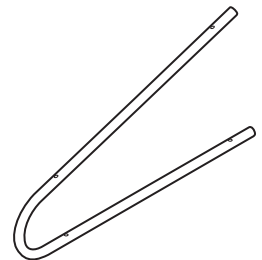

M 2X

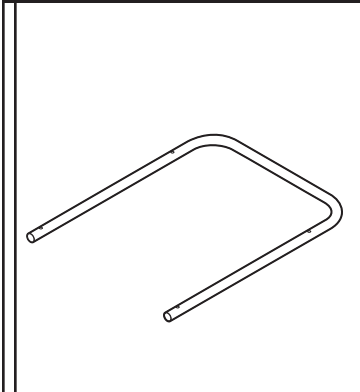

N 1X

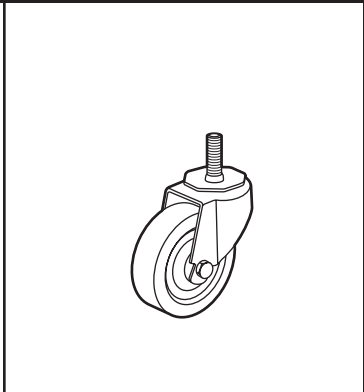

O 4X

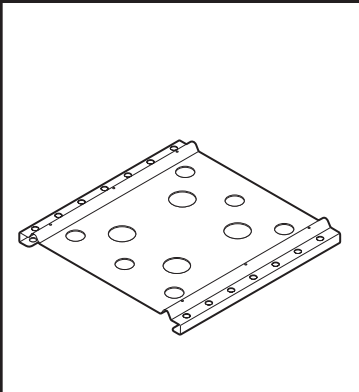

P 1X

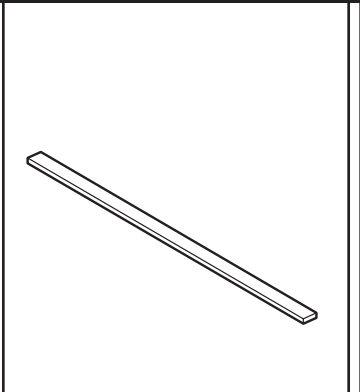

Q 2X

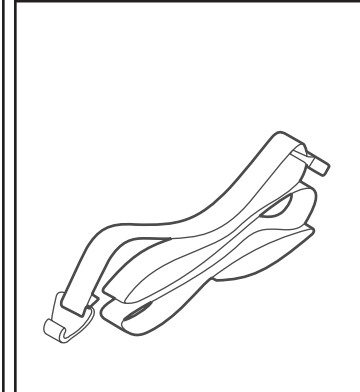

R 1X



S 4 Door Hard Top
Included in kit
#82210645



T 2 Door Hard Top
Included in kit
#82210644

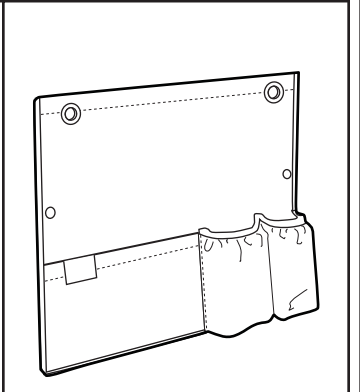

U

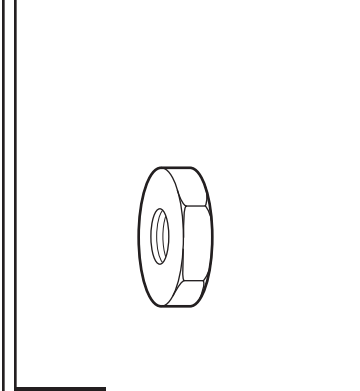

AA 4X

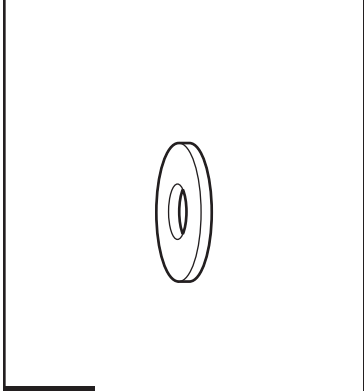

BB 2X

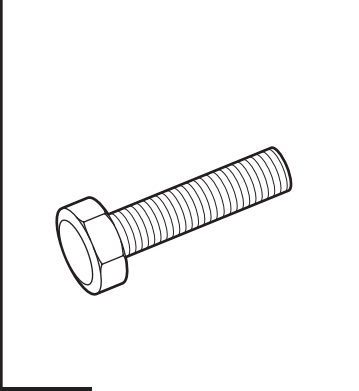

CC 2X

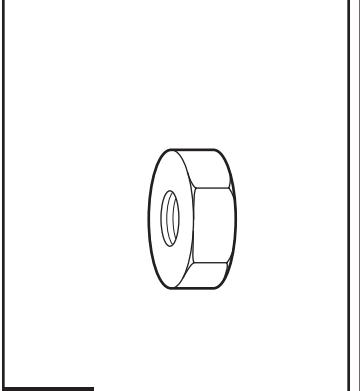

DD 2X

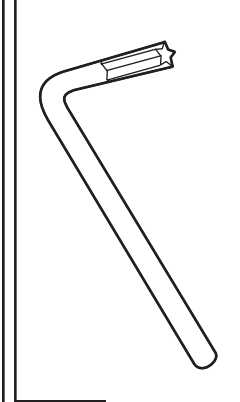

EE 1X

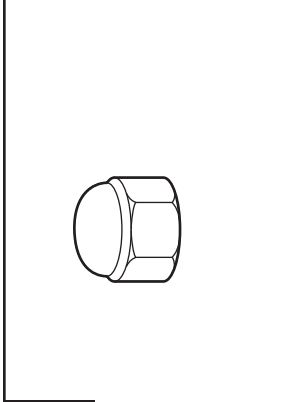

FF 4X

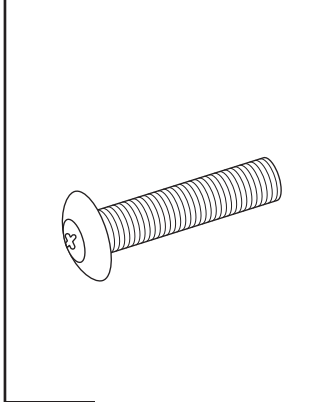

GG 4X

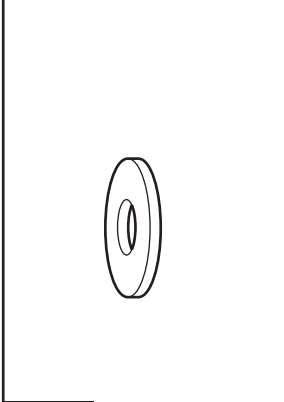

HH 4X

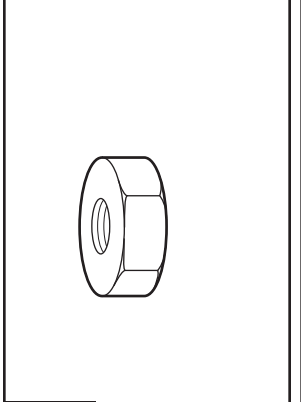

II 4X

7/16"
3/4"
9/16"

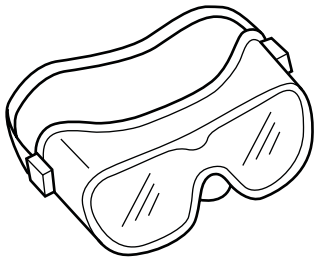
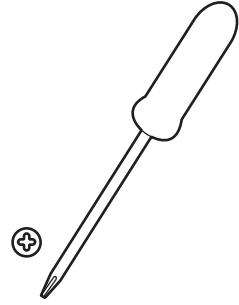
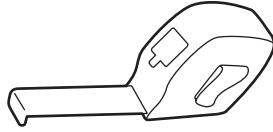
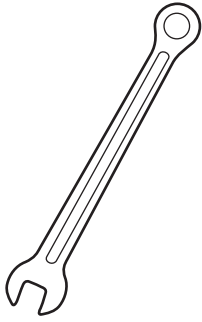

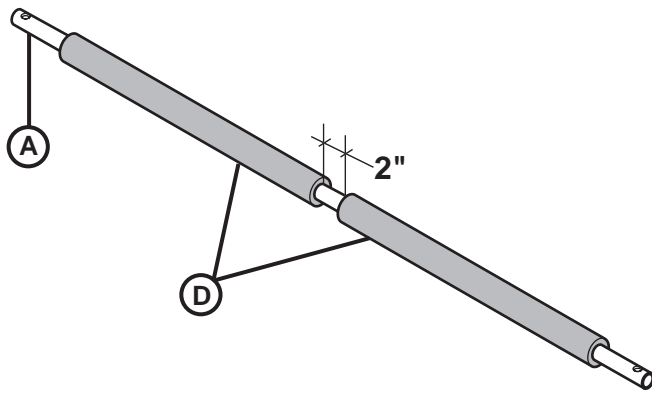

Slide two (2) of the long foam tubes over the front top cart tube and center them with a 2" space between them.

1

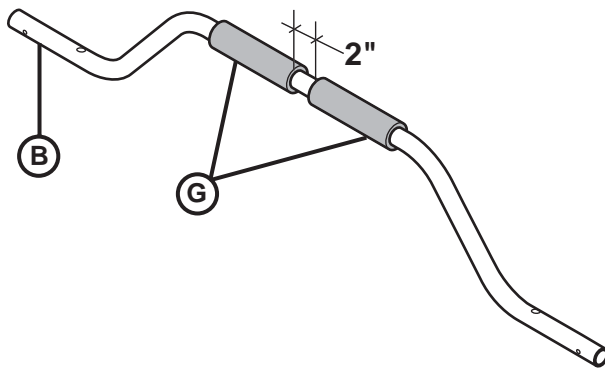

Slide two (2) short foam tubes onto the rear top cart tube and center them with a 2" space between them.

2

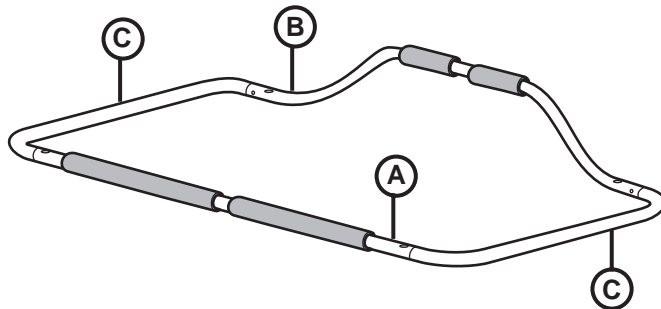

Orient the Front, Rear and Side Tubes to each other. Slide them together and line up all the holes.

3

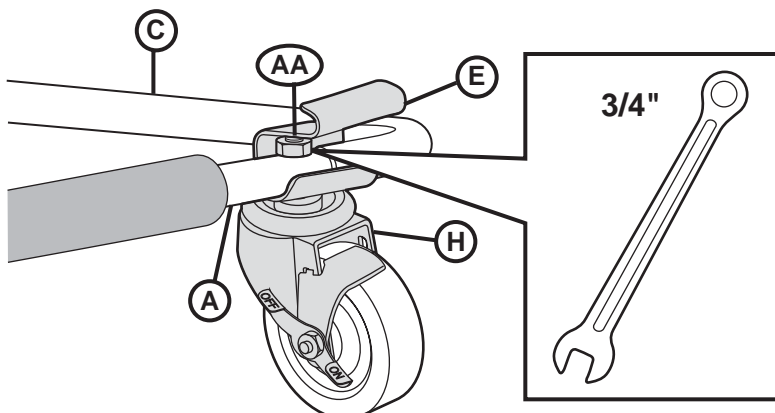

Slide the right corner hook onto the Front Tube. Place a 1/2-13 jam nut over the hole in the front tube. Install a top cart braking caster through both tubes, the hook and into the jam nut.

4

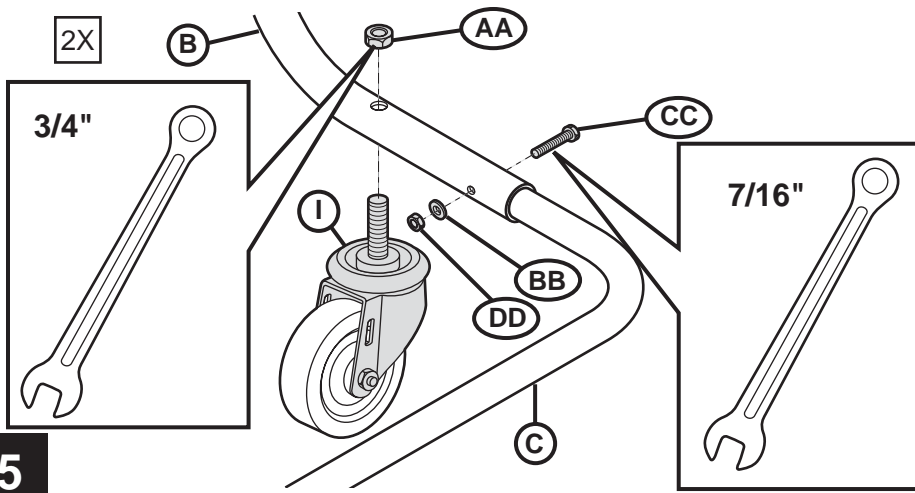

Place a top cart caster without a brake through the larger holes where the side and rear tubes join and secure it with a 1/2-13 jam nut. Then install a 1/4-20 x 1.5" hex bolt, a 1/4" washer and a 1/4-20 hex nut. Repeat this procedure with the other side tube/rear tube assembly.

5

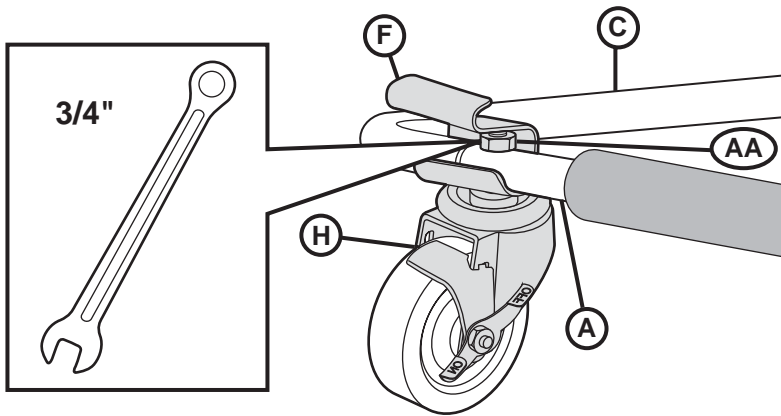

Slide the left corner hook onto the front tube. Slide the end of the left side tube into the end of the front tube assembly. Place a 1/2-13 jam nut over the hole in the front tube. Install a top cart braking caster through both tubes, the hook and into the jam nut. Securely tighten all hardware.

6

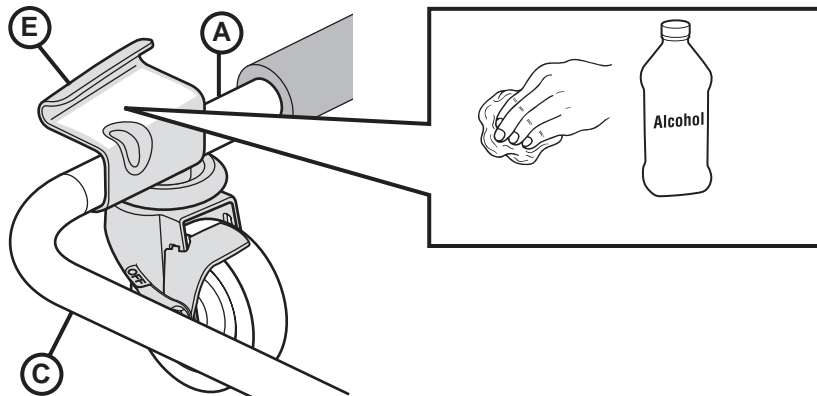

Clean the flat area on the corner hooks with alcohol.

7

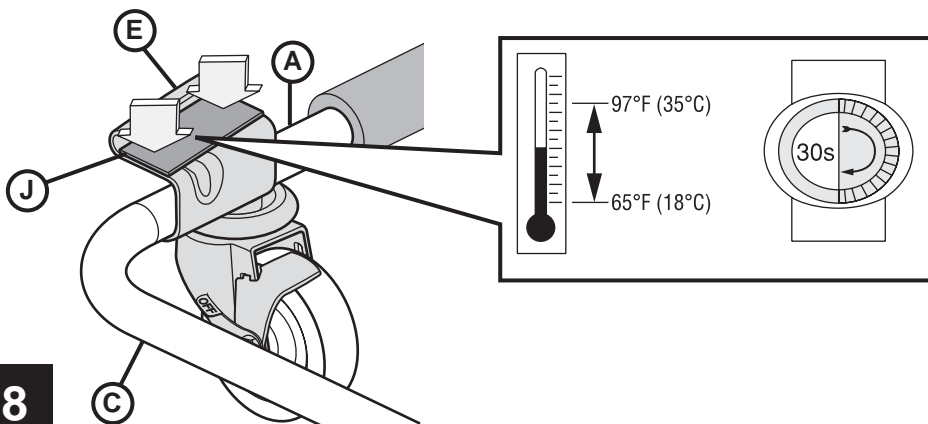

Orient the corner hook rubber pads to fit squarely on the corner hooks. Remove the backing from the pads and press them firmly onto the corner hooks. Apply uniform pressure for thirty (30) seconds.

8

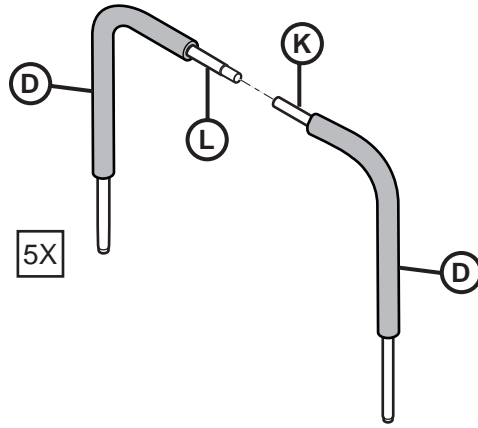

Slide a foam sleeve over one half of each pair of dividers. Slide the sleeve up and around the bend. Press the divider halves together. Assemble five (5) dividers.

9

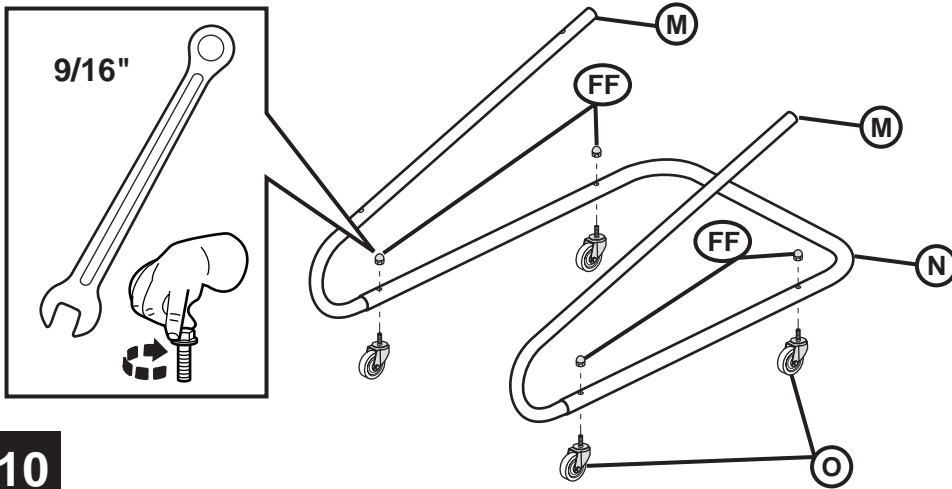

Slide the angle legs into the ends of the rear tube and align the holes. Install a door cart caster in each set of holes with a 3/8-16 acorn nut. Do not tighten the nuts at this time.

10

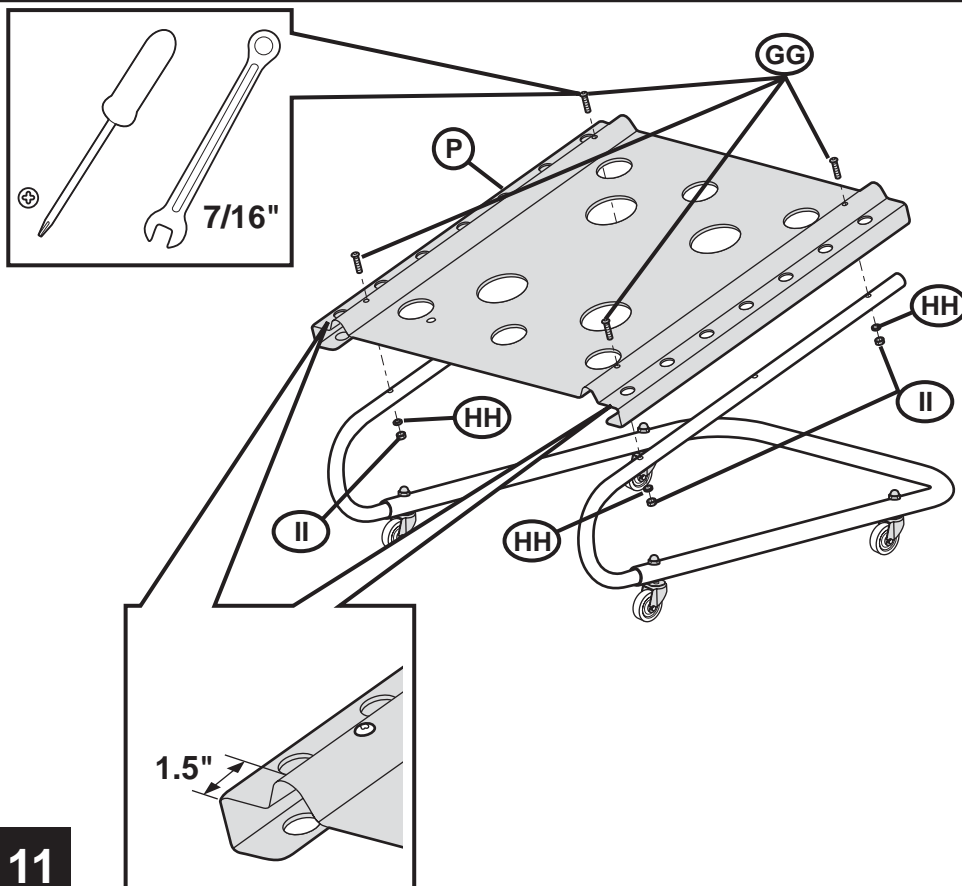

Orient the pan so that the bottom hole along the side is 1.5" from the bottom of the pan. Use 1/4-20 x 1.5 Truss Head Screws, 1/4" Washers and 1/4-20 Hex Nuts to secure the pan to the angle legs.

Tighten the truss head screws then tighten the acorn nuts on the casters.

11

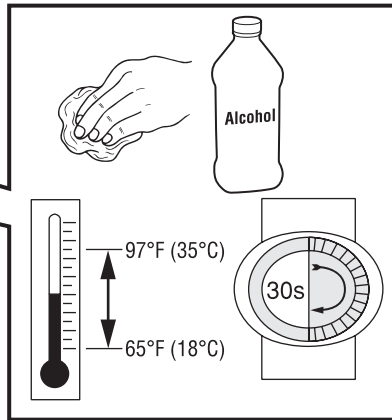
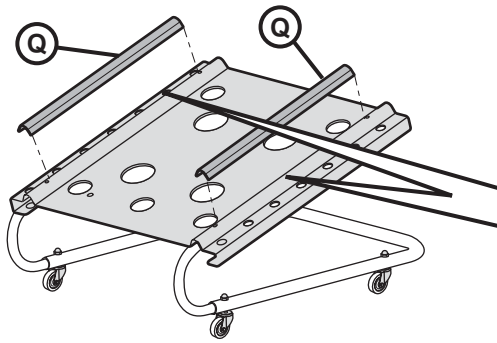

Clean the top of the mounting ridges with alcohol. Place the rubber strips on the top of the mounting ridges, over the truss head screws and center. Peel the backing a little at a time and press firmly into place. Apply uniform pressure for thirty (30) seconds.

12

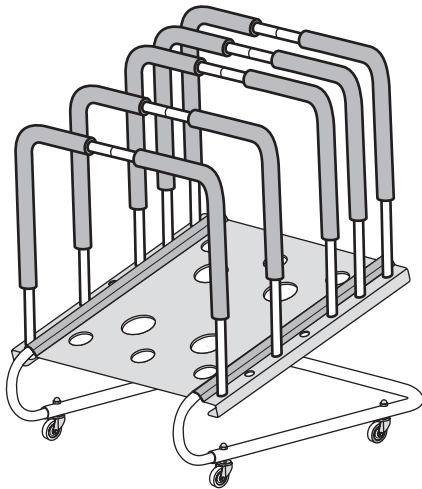

Insert dividers into the holes along sides of pan. Dividers should fit securely into mounting holes.

13

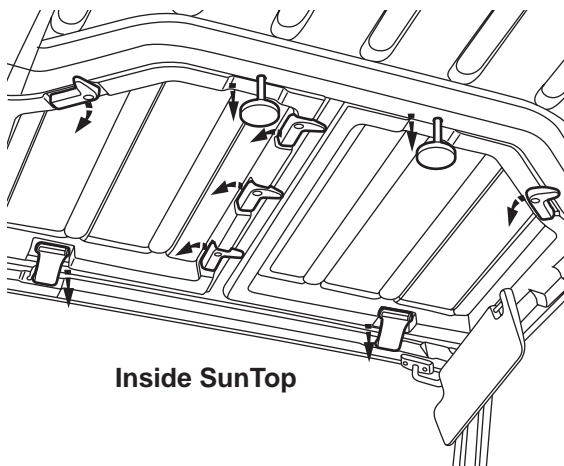

Inside SunTop

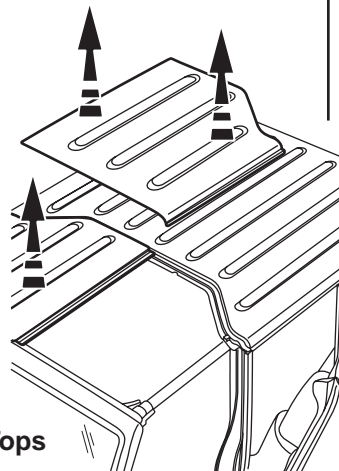

Remove SunTops

Release the levers that secure the SunTops to the windshield. Release the knobs that secure the SunTops to the rear deck. Release the Levers. Remove the SunTops from the vehicle.

14

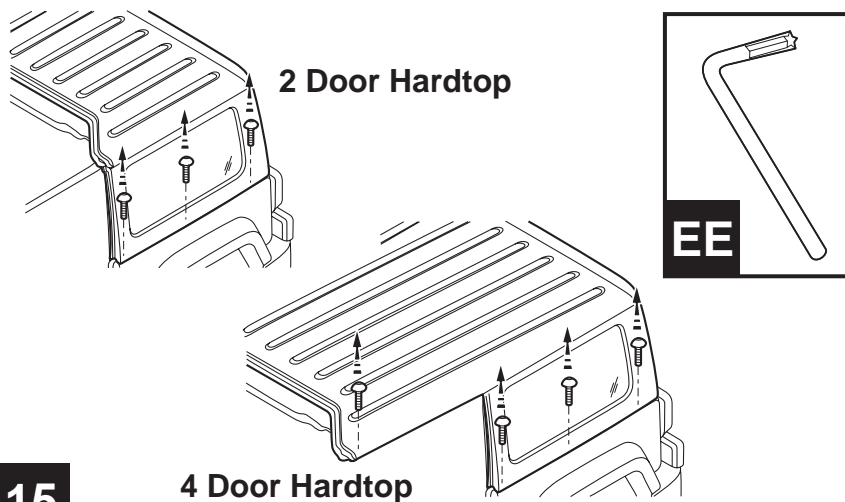

Use the T40 Torx Wrench to remove the six (6) Torx Bolts that secure the 2 Door Hardtop or the eight (8) Torx Bolts that secure the 4 Door Hardtop.

Carefully store the bolts to be used when reinstalling the top.

15

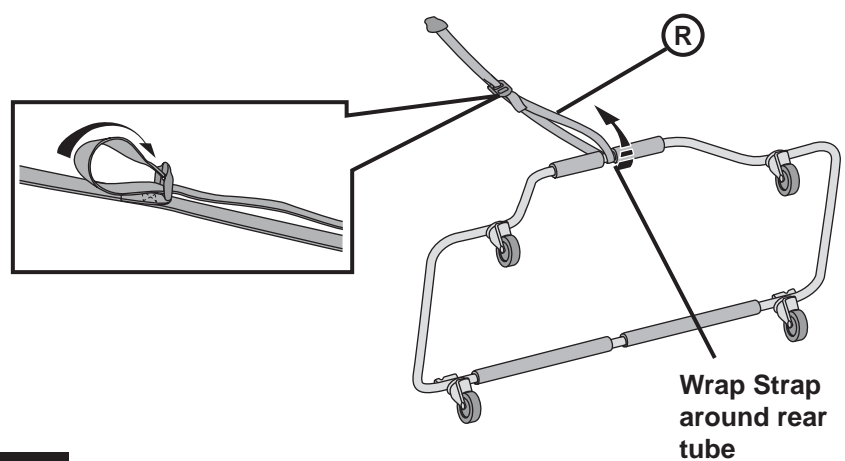

Orient the strap with the buckle facing the rear of the top cart. Wrap the straight end of the strap around the rear tube in the space between the two foam sleeves. Pull it toward the buckle in the middle of the strap without twisting.

Thread the end of the strap through the buckle.

16

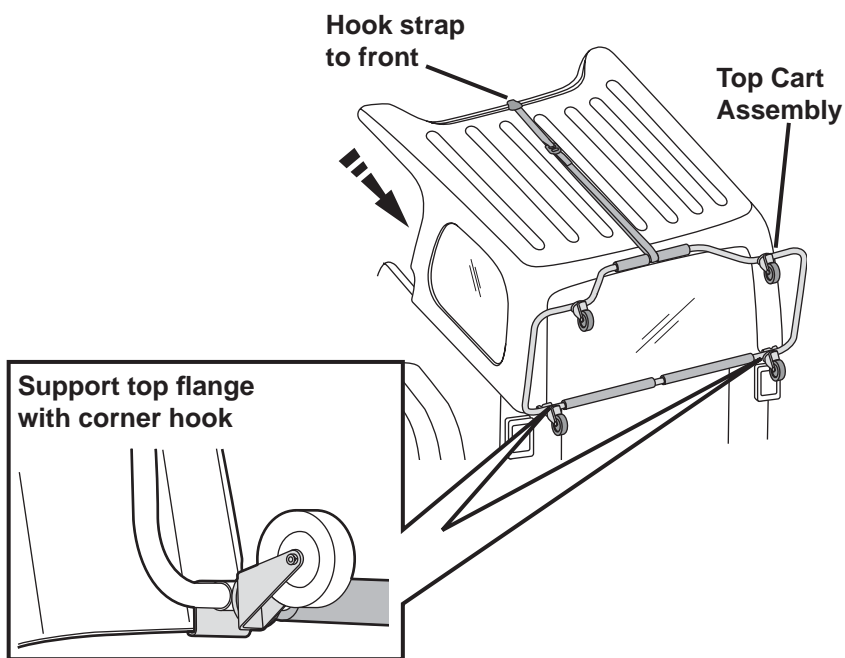

CAUTION
Four or more people are required to lift the hardtop safely.

Slide the top back slightly, but leave on the vehicle.

Place the Top Cart against the rear of the top with the Rear Tube toward the top.

Position Right and Left Corner Hooks on the cart under the rear flange of the hardtop for maximum support.

Hook the strap to the front of the hardtop. Pull the strap as tight as possible.

17

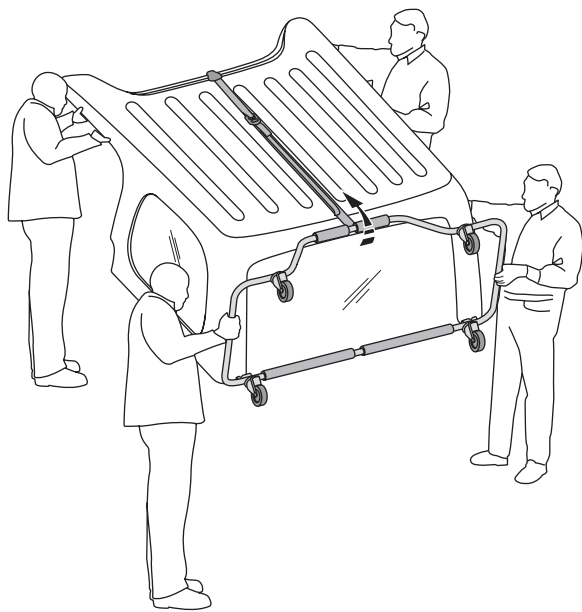

18



CAUTION

Four or more people are required to lift the hardtop safely.

Use the Side Tubes as handles to lift the hard top and Top Cart off the vehicle and move toward the rear. Slowly place the top in its normal position down on the ground next to the vehicle. Re-check that the strap is secure.

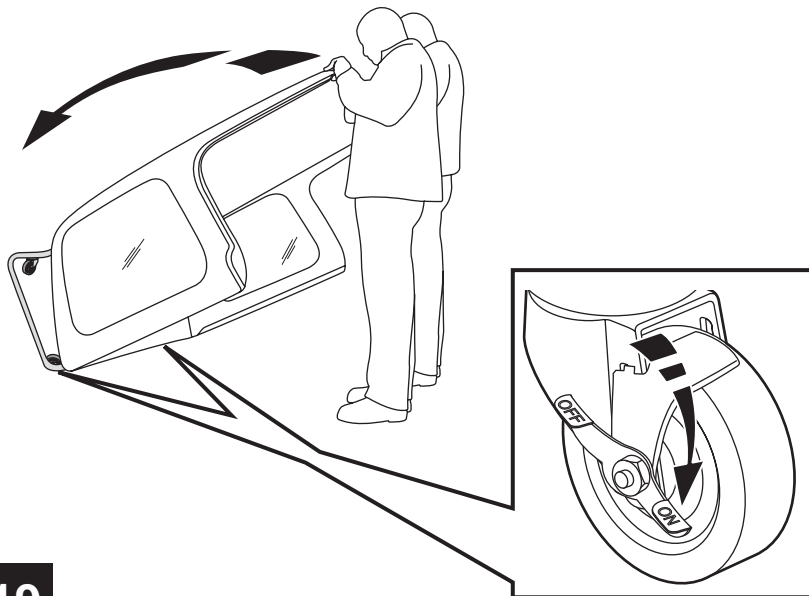

19



CAUTION

Two or more people are required to lift the hardtop safely.

Lock the front brake casters. Slowly lift the front of the hardtop until it is completely resting on the top cart casters. Do not allow the hardtop to rock backwards as it approaches the full upright position.



Roll door cart into top cart and load with doors. Center the cart in the top.

20

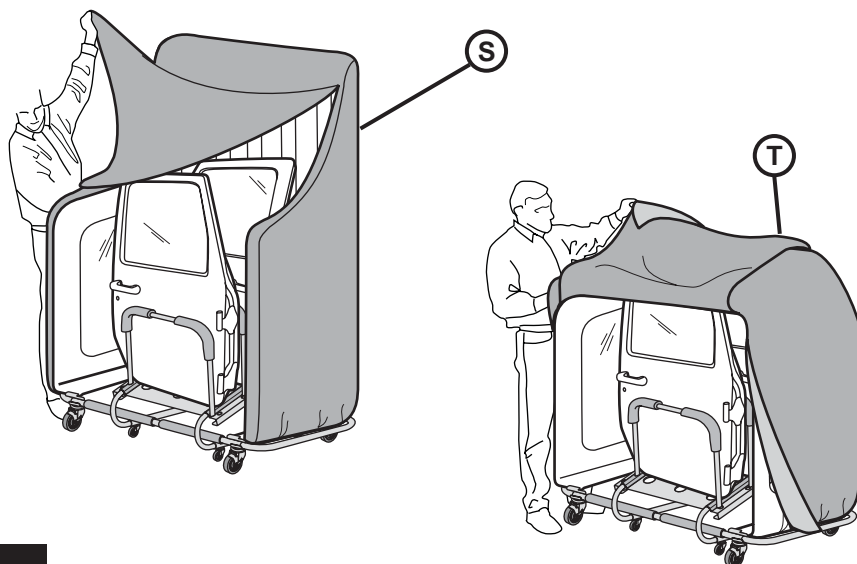

Drape cover over top cart. Close zippers.

21

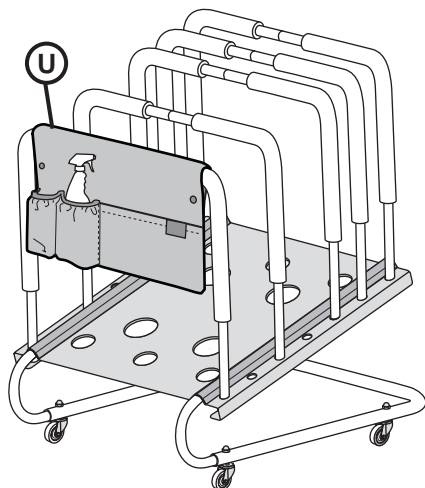

Wrap top of tool caddy around top of a door cart divider and secure with hook and loop fastener. Store tools, hardware and cleaner bottles.

22