



MOPAR®

JEEP WRANGLER

Front Bumper

#82209740AC and 82210341

Kit # 82209740AC

A		K 2x	J * 4x
B 12x	D 4x		See steps 1-9 then proceed to steps 18-31
C 2x	G 12x	I 2x	
		F 2x	H 2x
			* Required to install winch.

Kit # 82210341

		See steps 1-17	
E			
B 12x			
C 2x	G 12x	K 2x	H 2x

8mm
15mm
18mm

7/16"

9/16"

Loctite

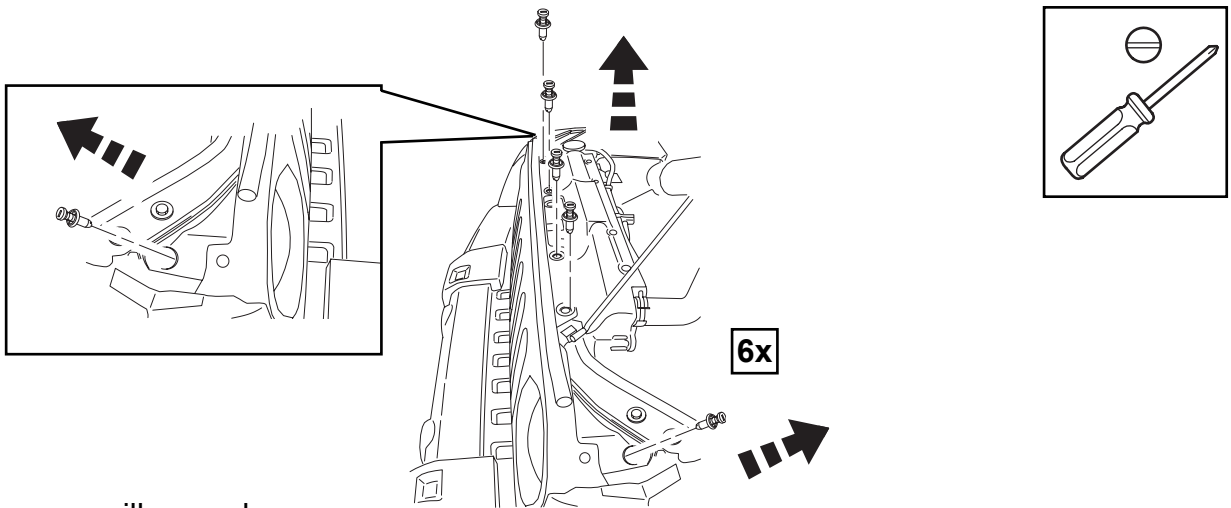

Remove grille panel.

1

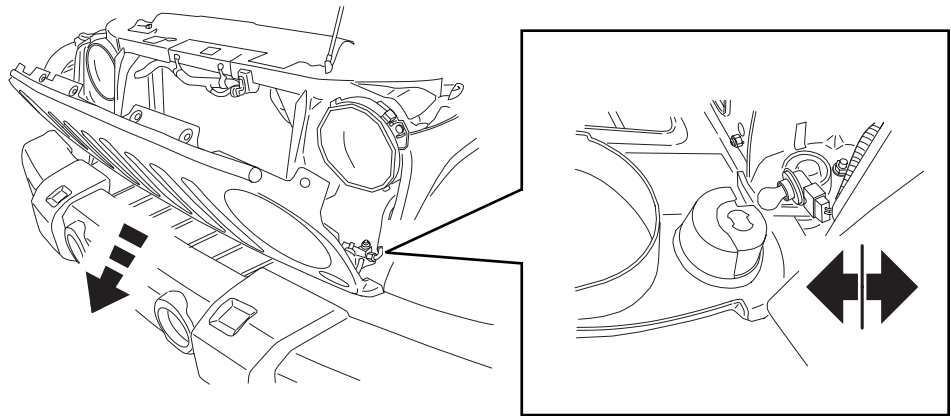

Disconnect bulb assembly on each side.

2

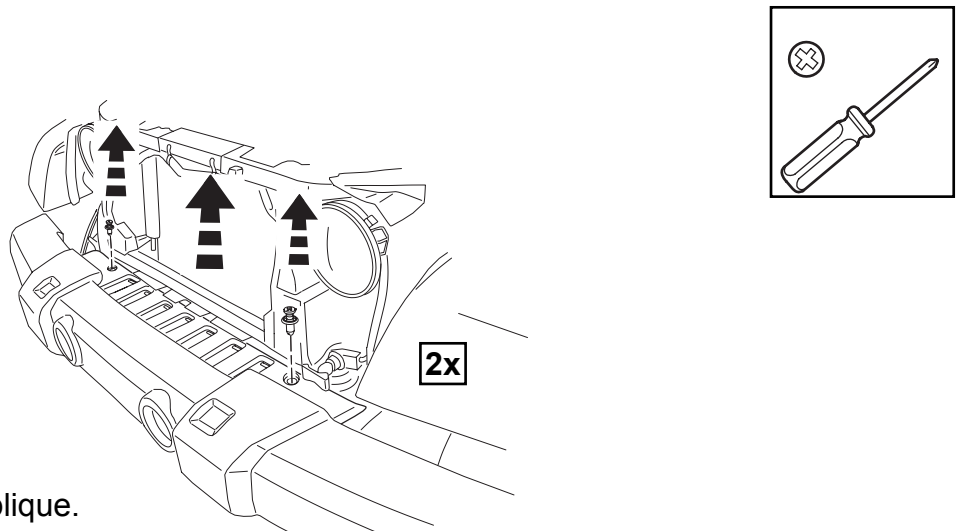

Remove bumper applique.

3

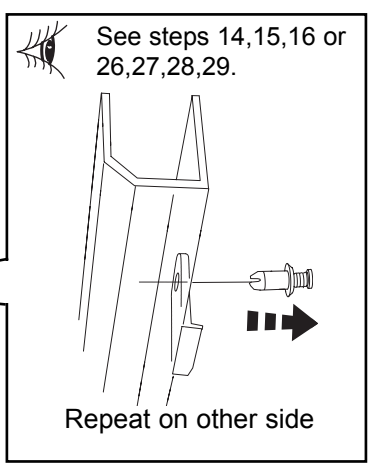
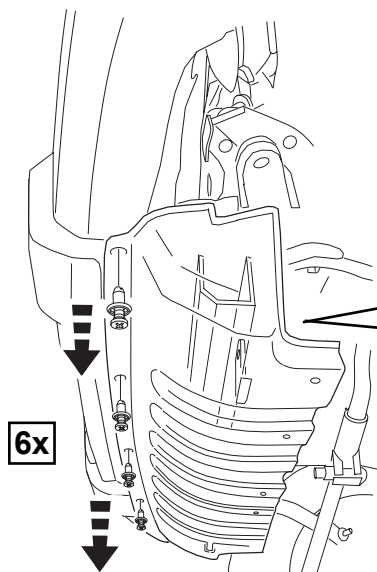

Remove lower splash shield.

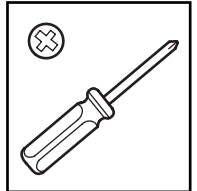
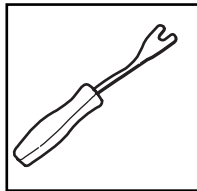
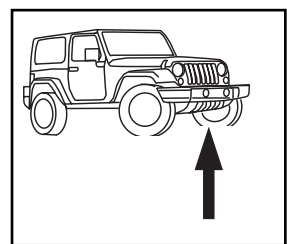

4

See steps 10,12, 20 & 22

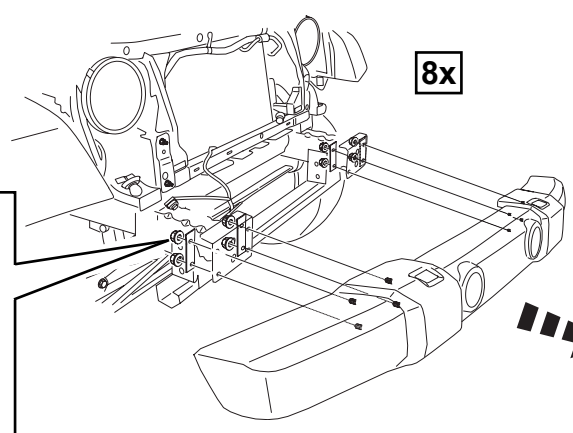

Fascia shown without Tow Hooks

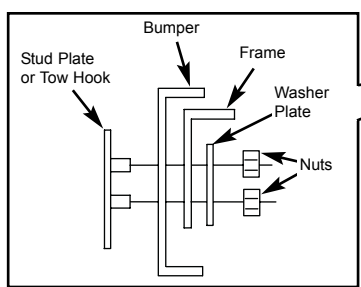
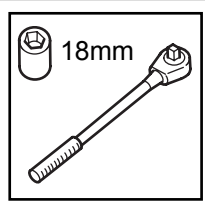

Save nuts & washer plates for re-use in steps 10, 12, or 20,22.

*Note: Additional Fog Lamp Kits, Driving Lamp Kits and Wiring Installation Kits are available to be added to the holes provided in the bumper.

5

Disconnect fog lamp harness if equipped.

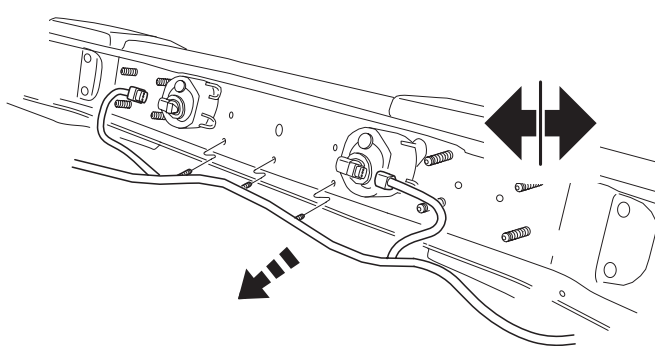
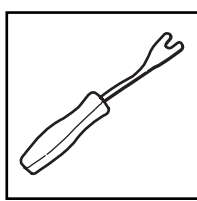

6

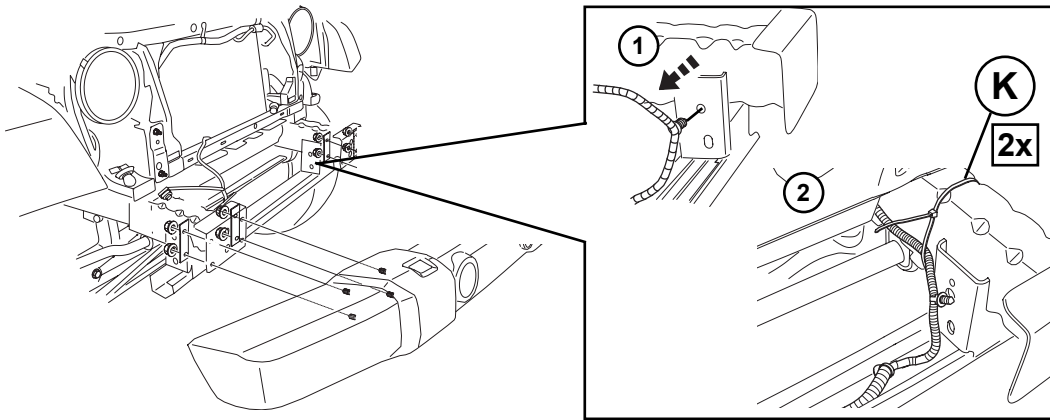

- 1) Tie Strap loose harness out of way.
- 2) Disconnect wire harness.
- 3) Using Item K, tie wrap securely in place to vehicle on both sides.

7

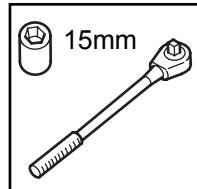
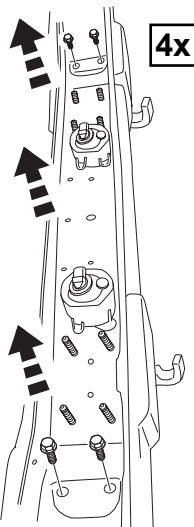

Remove crossmember to access stud plates. If equipped, remove tow hooks.

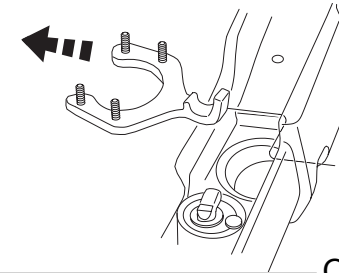

See step 12
Fascia with Tow Hooks

OR

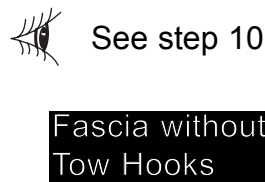

See step 10
Fascia without Tow Hooks

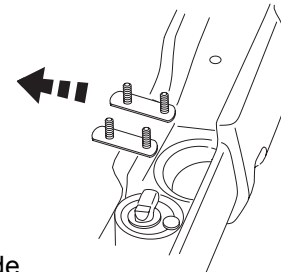

8

9

Repeat on other side

Kit # 82210341 - Vehicle without Tow Hooks

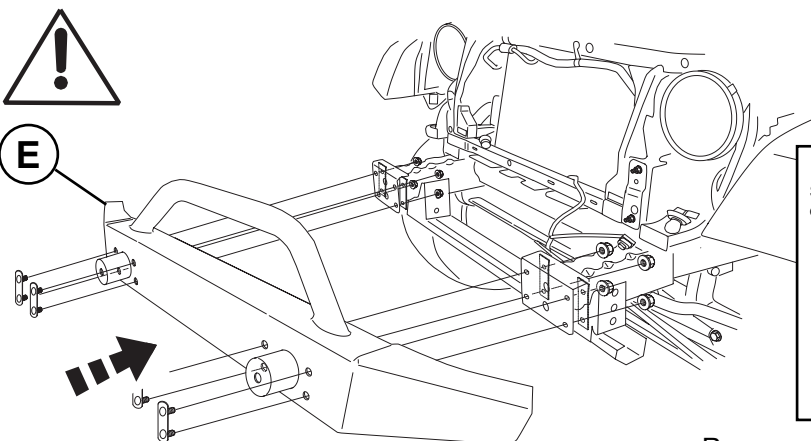

100 N.m / 75 ft-lbs

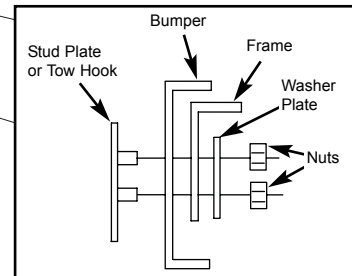

Re-use nuts and washer plates from Step 5 and stud plates from Step 9.

After leveling the bumper for best appearance, torque hardware as shown.

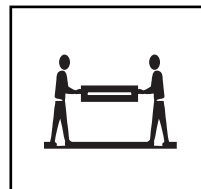
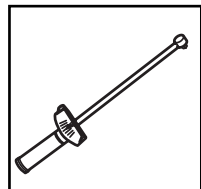
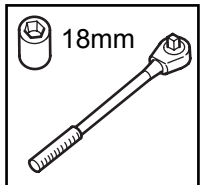

10

Vehicles without Tow Hooks, opening at bottom.

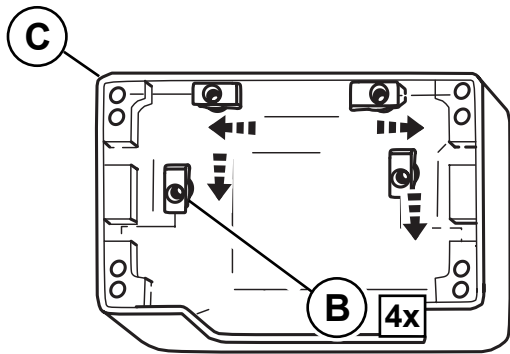

Install U-nuts as shown, correct orientation is important for proper installation.

11A

Kit # 82210341 - Vehicle with Tow Hooks



Do not over-torque

11 N.m / 96 in-lbs.

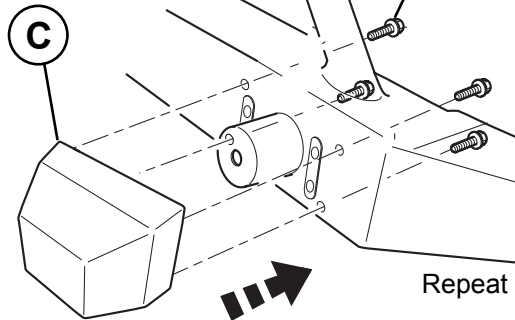

Repeat on other side

11B

Note: View without Tow Hook

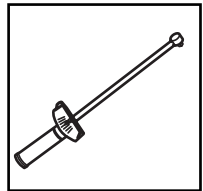
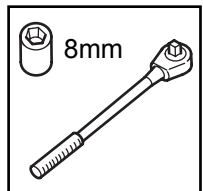

Vehicles with Tow Hooks

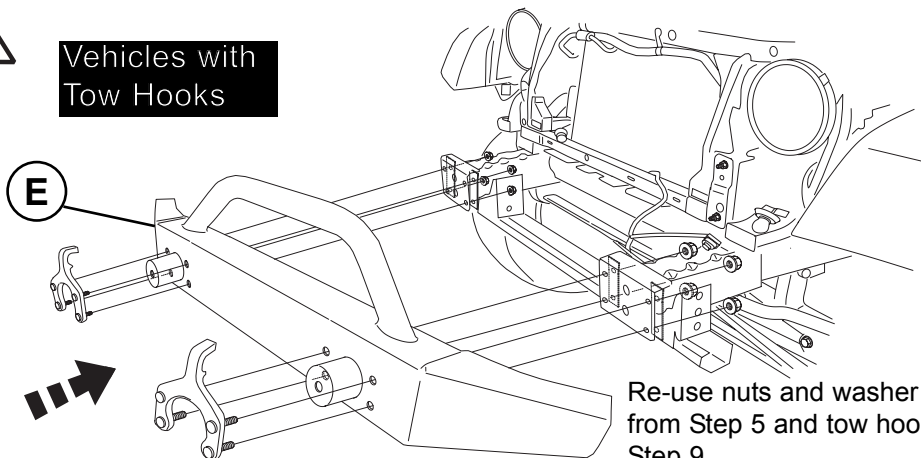

Re-use nuts and washer plates from Step 5 and tow hooks from Step 9.

After leveling the bumper for best appearance, torque hardware as shown.

12

100 N.m / 75 ft-lbs

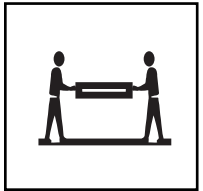
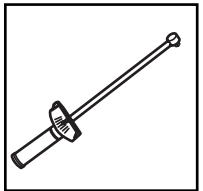
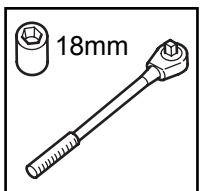

Vehicles with Tow Hooks, opening at top.

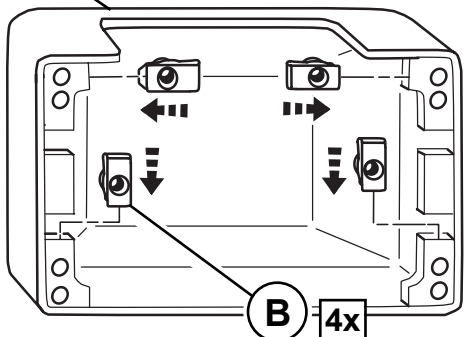

Install U-nuts as shown, correct orientation is important for proper installation.

13A



Do not over-torque

11 N.m / 96 in-lbs.

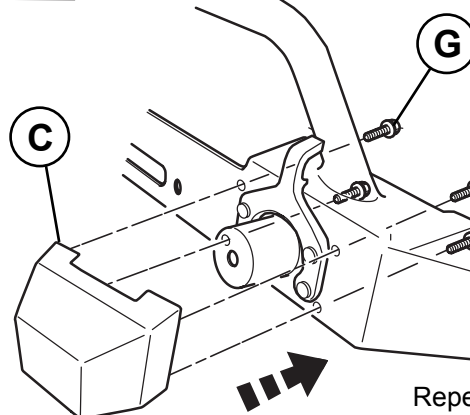

Repeat on other side

13B

Note: View with Tow Hook

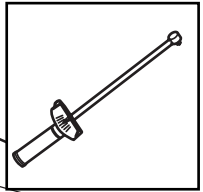
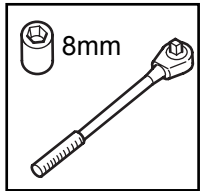



Trim plastic 4X, see step 14B detail, if installing a non-winch bumper.

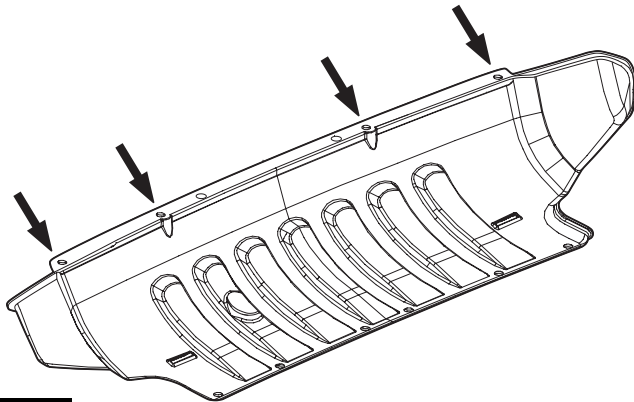

14A

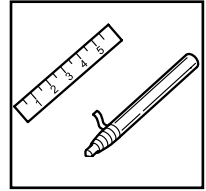
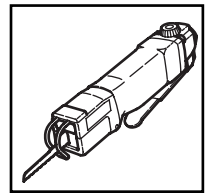
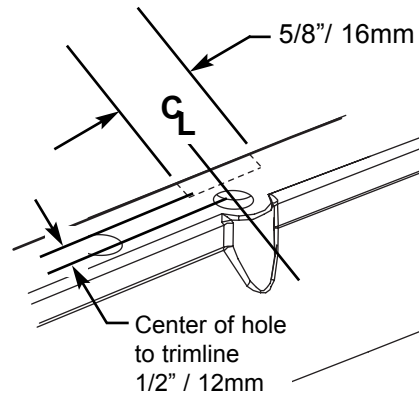

14B

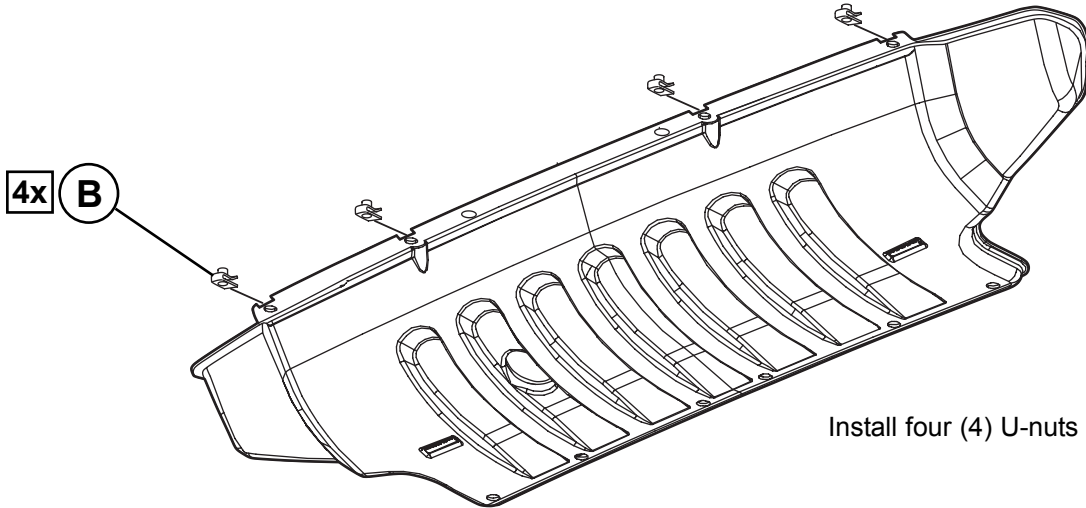

Install four (4) U-nuts (item B).

15

Kit # 82210341

12 N.m / 8 ft-lbs

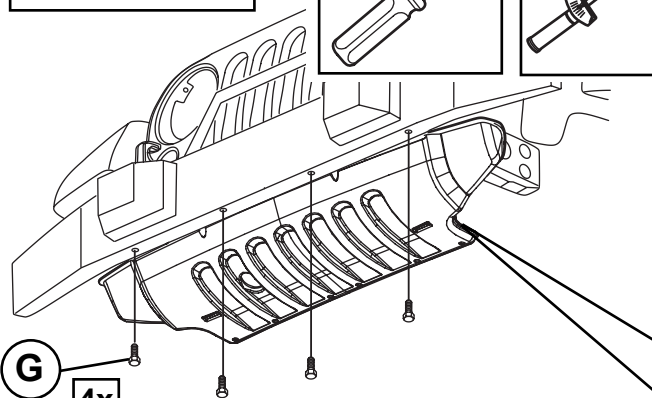
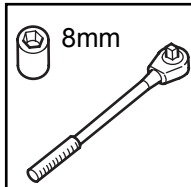
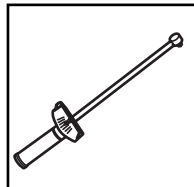
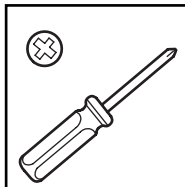

16

Splashshield is designed to be positioned above rear bumper flange.

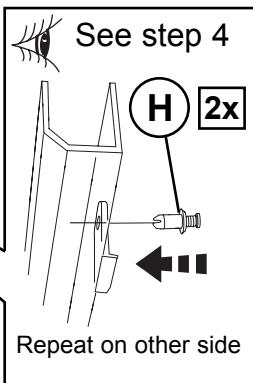

17



See steps 1-3

Reverse Steps 3, 2 then 1 for re-installation.

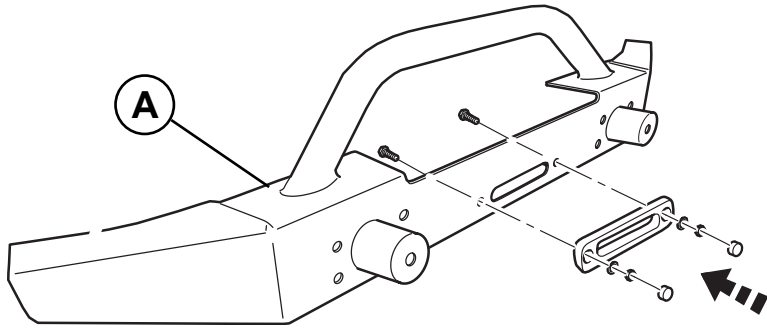

Hawse Fairlead and hardware not included in Bumper Kit # 82209740AC.

18



Winch must be positioned into bumper before the bumper is attached to the vehicle.

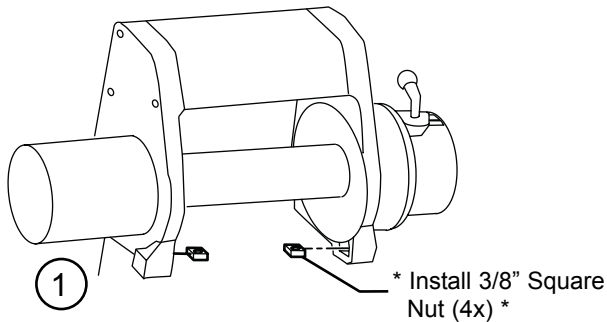

Note: If installing winch, rest winch in place, do not install bolts (item J). It will be necessary to move winch (side to side) to install bumper hardware.

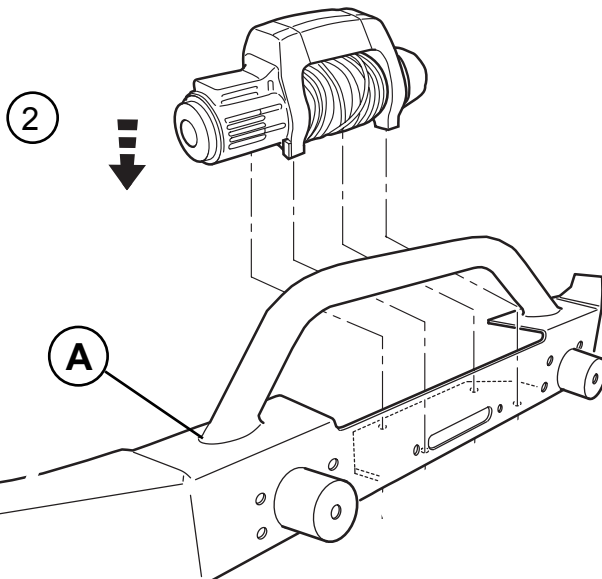

Winch not included in Bumper Kit # 82209740AC.

* 3/8" Square Nuts included in winch kit. The 3/8" bolts in winch kit will not be used. *

19

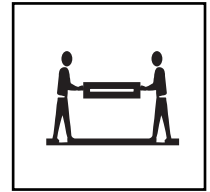

HAND TIGHTEN ONLY

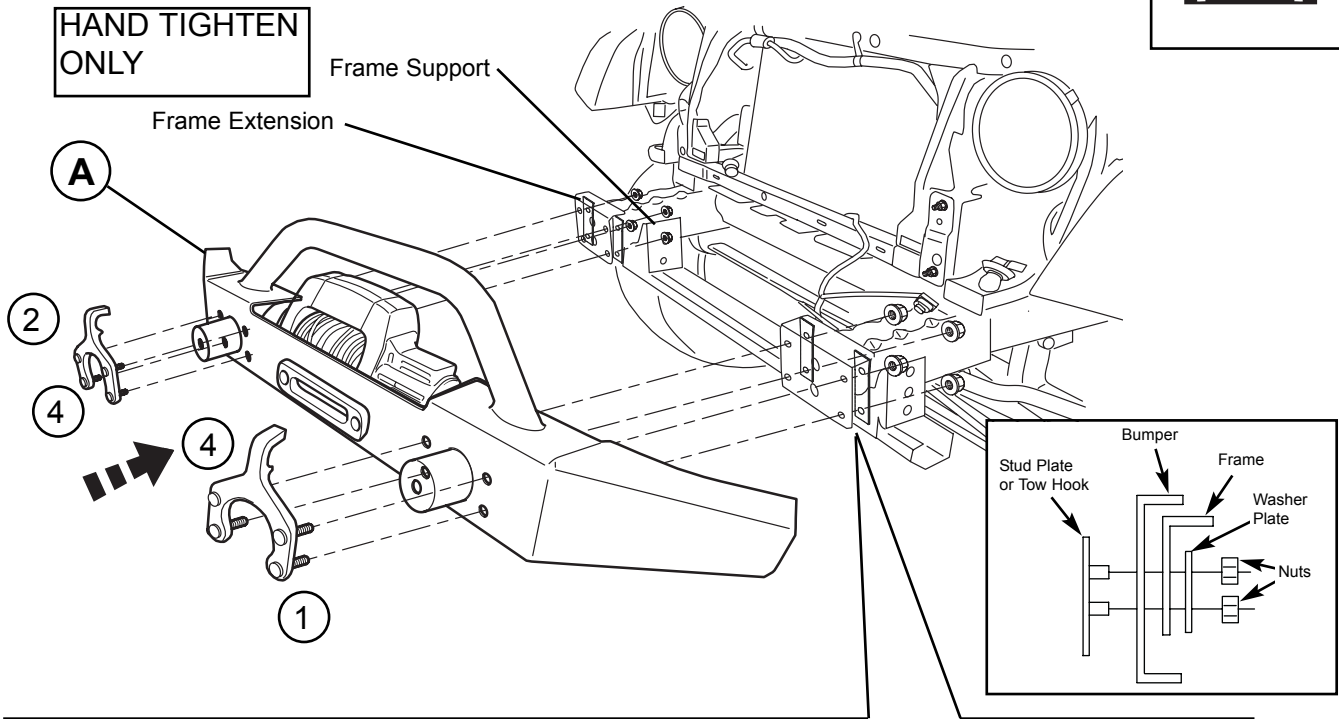

*Note: Due to vehicle variations, gaps may be present between the Lower Rear Bumper Bracket and the Frame Support. If gaps are present, install washers (item D, up to 2x per side) between the Lower Rear Bumper Bracket and the Frame Support.

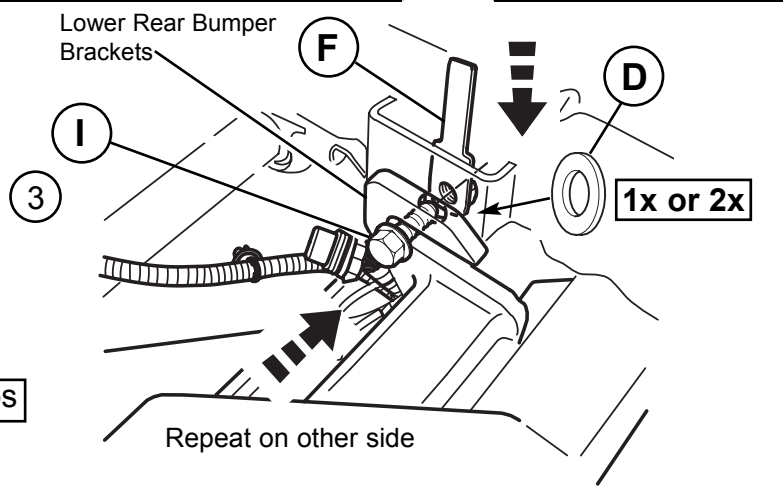

Rotate Bumper under frame extension to align lower rear bumper bracket slots to frame support hole (see frame 7) and then loosely install two tow hooks with nuts and washer plates (removed in step 5). Now loosely install bolts (item I) to handle nuts (item F). Due to vehicle variations, washers (item D) are supplied to eliminate gaps.

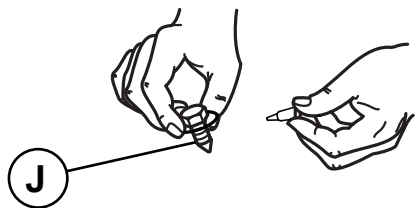

Apply Loctite to Bolts (Item J), 4 total.

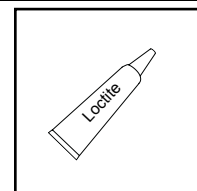

21

Vehicles without
Tow Hooks

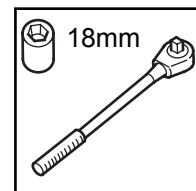
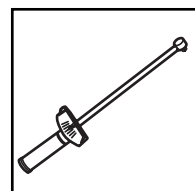

8x 100 N.m / 75 ft-lbs

A

4x **J**

55 N.m / 40 ft-lbs

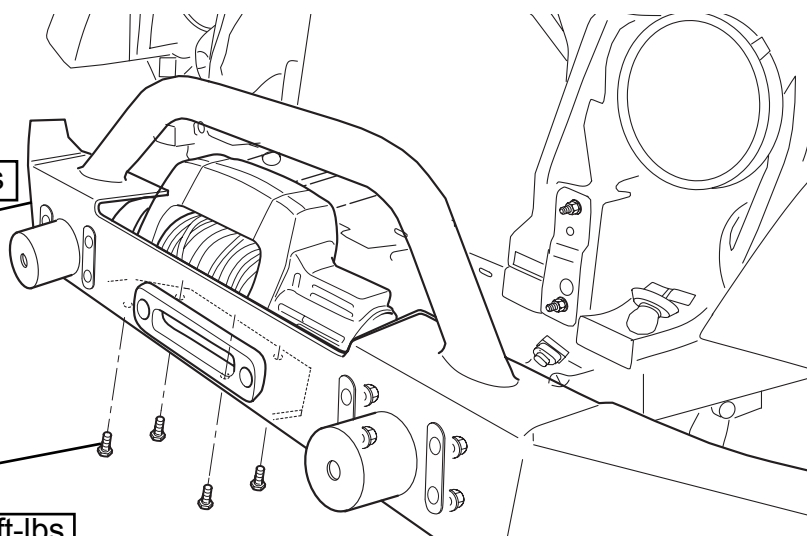

After leveling the bumper for best appearance, torque hardware as shown 8 places.

Install Winch using bolts (Item J) provided.

Note: If bolts do not align to nuts in the winch legs, the holes in bumper may need to be enlarged slightly. If this procedure is required, deburr the holes/slots and apply Mopar Rust Inhibitor 82300508 to all bare edges and allow to dry.

22

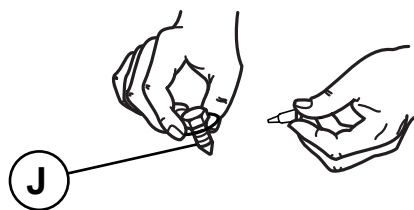

Apply Loctite to Bolts (Item J), 4 total.

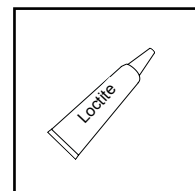

23

Vehicles with
Tow Hooks

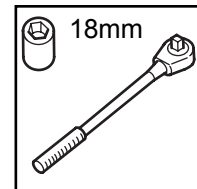
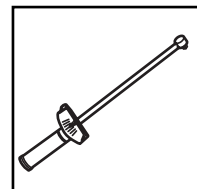

8x 100 N.m / 75 ft-lbs

A

4x J

55 N.m / 40 ft-lbs

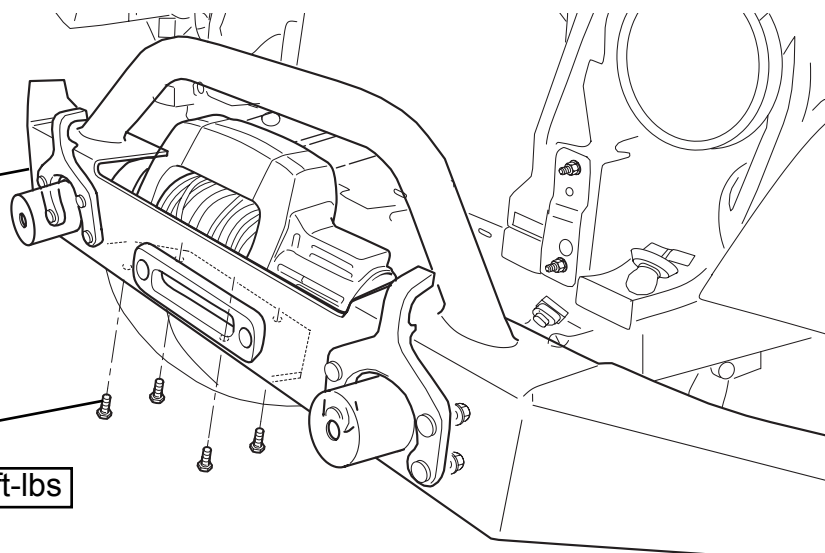

After leveling the bumper for best appearance, torque hardware as shown 8 places.

Install Winch using bolts (Item J) provided.

Note: If bolts do not align to nuts in the winch legs, the holes in bumper may need to be enlarged slightly. If this procedure is required, deburr the holes/slots and apply Mopar Rust Inhibitor 82300508 to all bare edges and allow to dry.

24

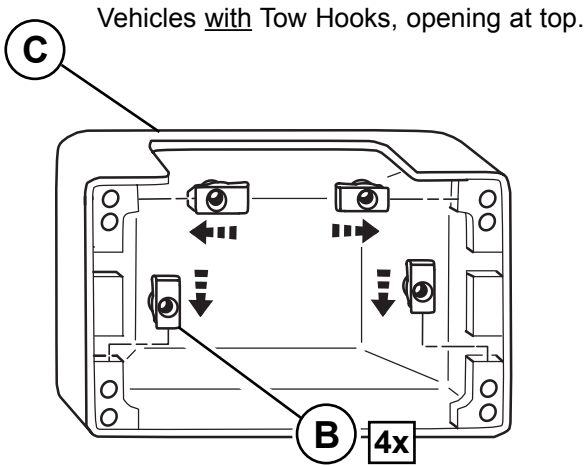

Install U-nuts as shown, correct orientation is important for proper installation.

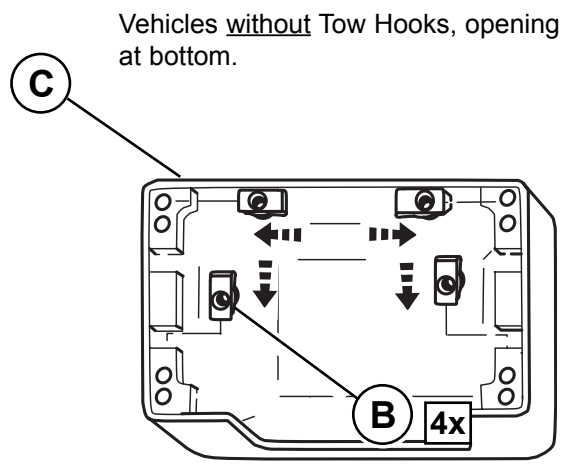

Install U-nuts as shown, correct orientation is important for proper installation.

25



11 N.m / 96 in-lbs.

Do not over-torque

Repeat on other side

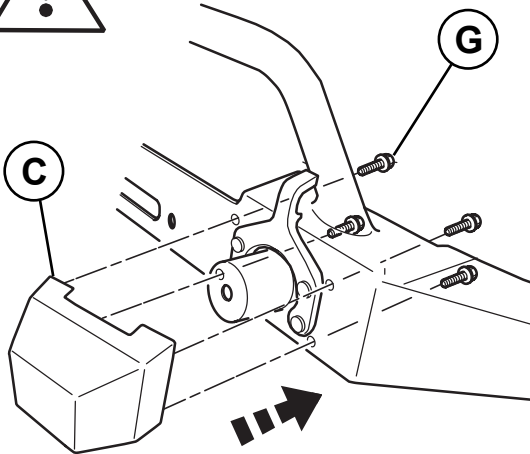

Note: View with Tow Hook

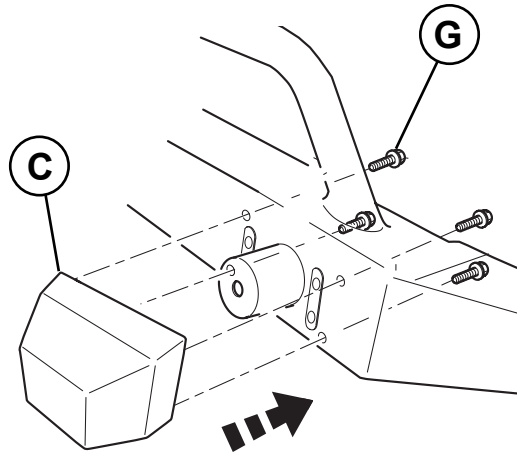

Note: View without Tow Hook

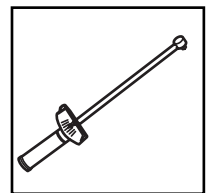
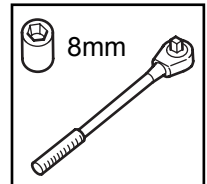

26

Kit # 82209740AC

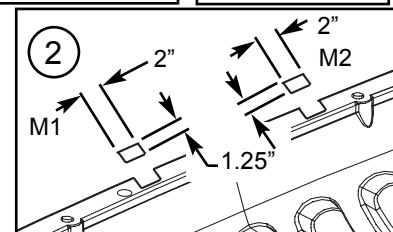
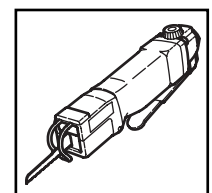
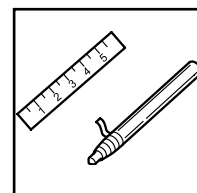
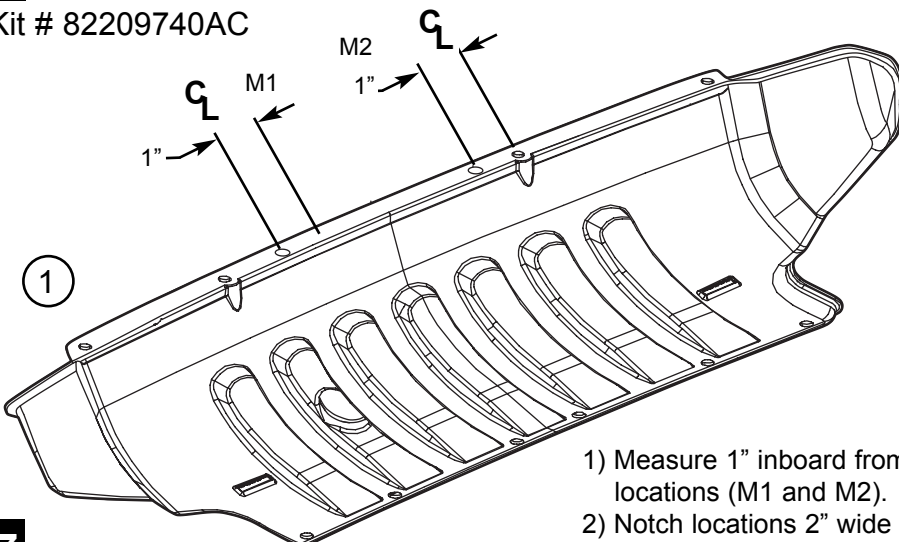

1) Measure 1" inboard from centerline of holes and mark locations (M1 and M2).

2) Notch locations 2" wide and 1.25" deep.

27



Trim plastic 2X , see step 28B for detail

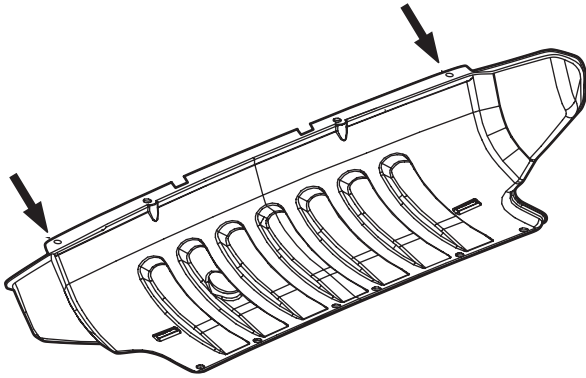

28A

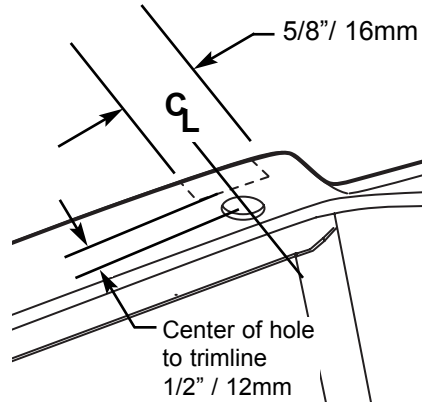

28B

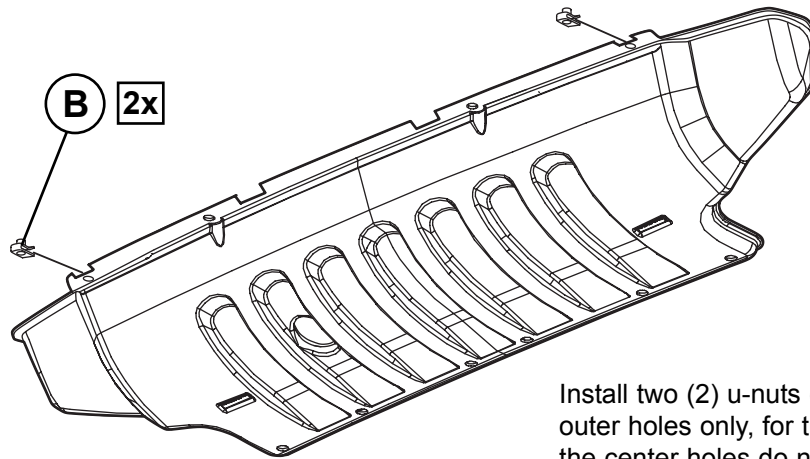
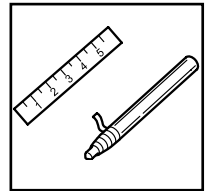
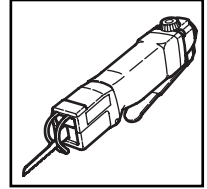

Install two (2) u-nuts (item B) to the outer holes only, for the Winch Bumper the center holes do not require u-nuts for attachment.

29

Kit # 82209740AC

12 N.m / 8 ft-lbs

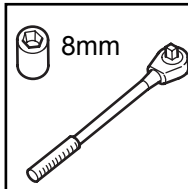
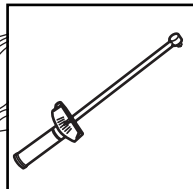
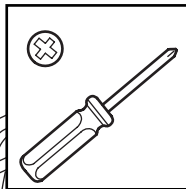

See steps 1-3

Reverse Steps 3, 2 then 1 for re-installation.

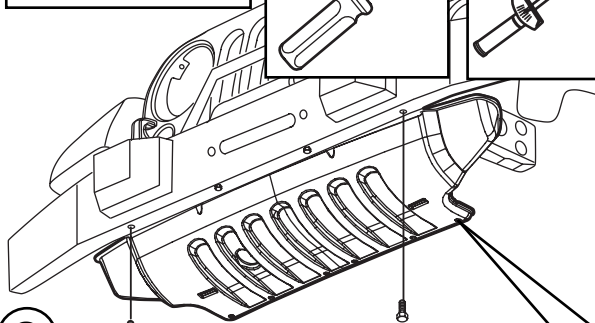

2x **G**

Splashshield is designed to be positioned above rear bumper flange. Outer holes (2) are used to attach splashshield.

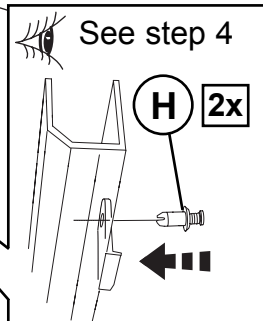

See step 4

H **2x**

Repeat on other side

30

31