



JEEP WRANGLER

Front Bumper

#82209740AD, 82211715, 82210341AC, 82211716
82211715AC and 82211716AC

Kit # 82209740AD

Kit # 82211715, 82211715AC

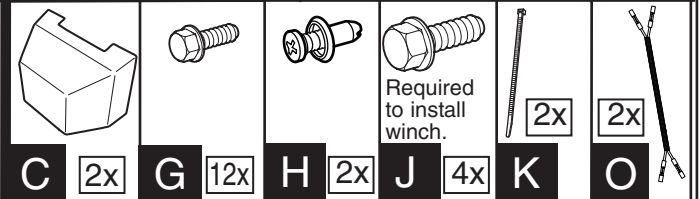
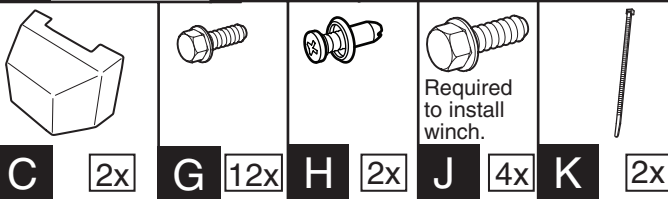
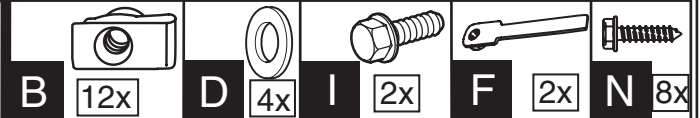
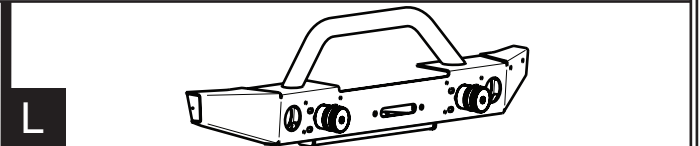
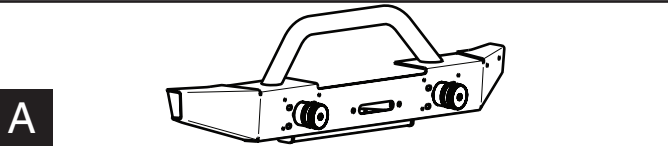

See steps 1-11, then proceed to steps 20-33
* Required to install winch

See steps 1-11, then proceed to steps 20-33
* Required to install winch

Kit # 82210341AC

Kit # 82211716, 82211716AC

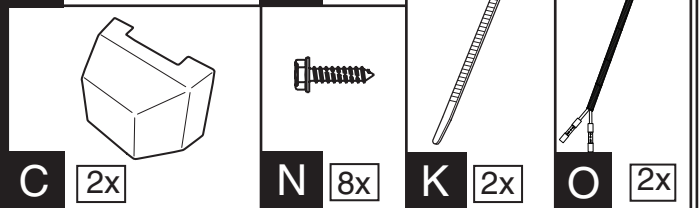
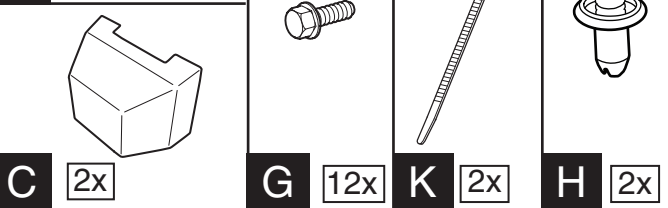
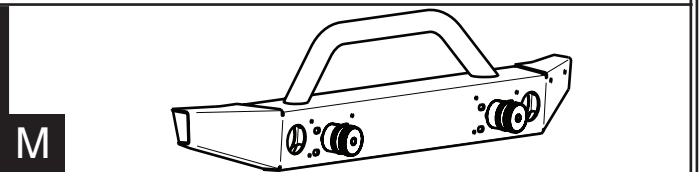
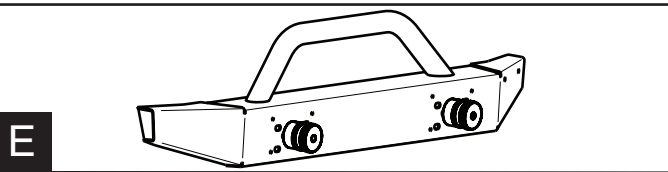

See steps 1-19

See steps 1-19

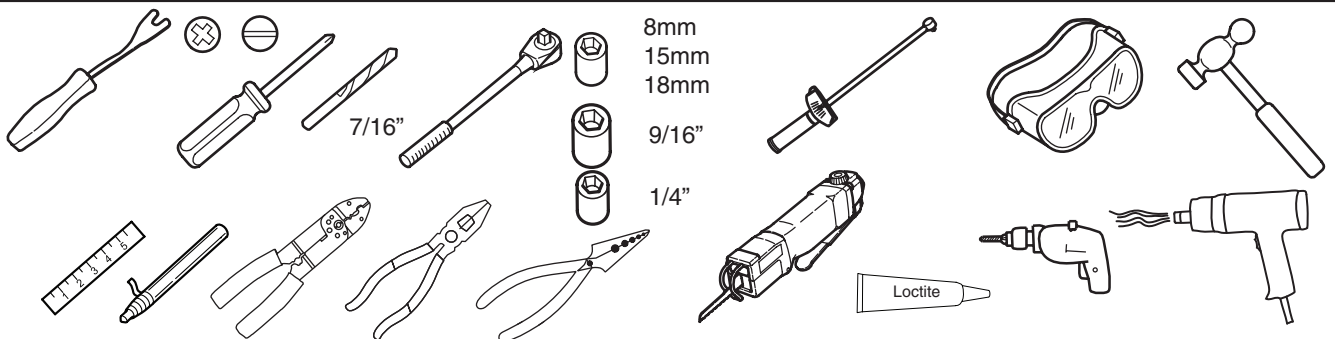

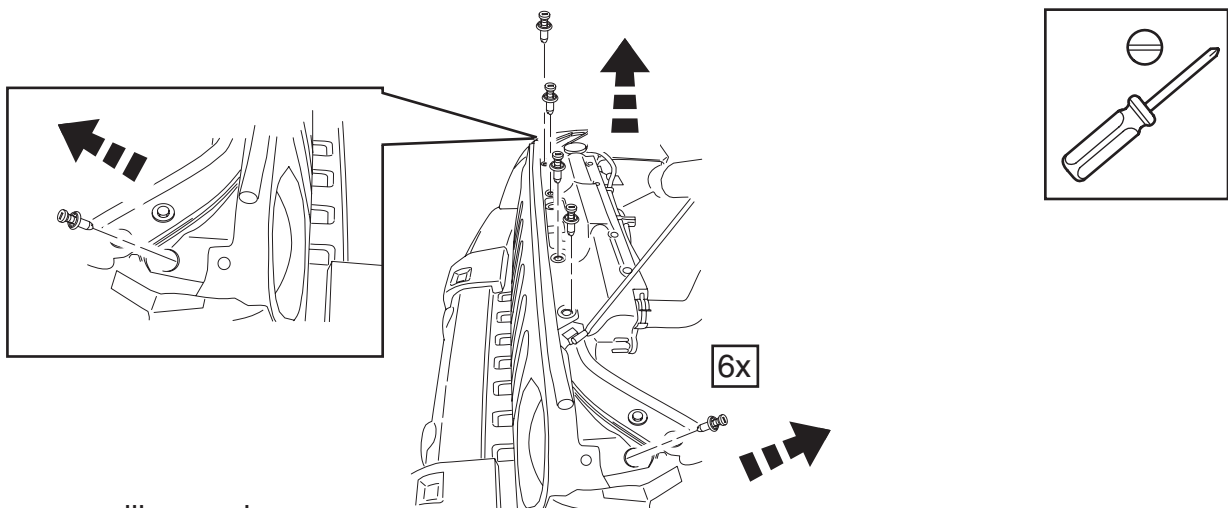

Remove grille panel.

1

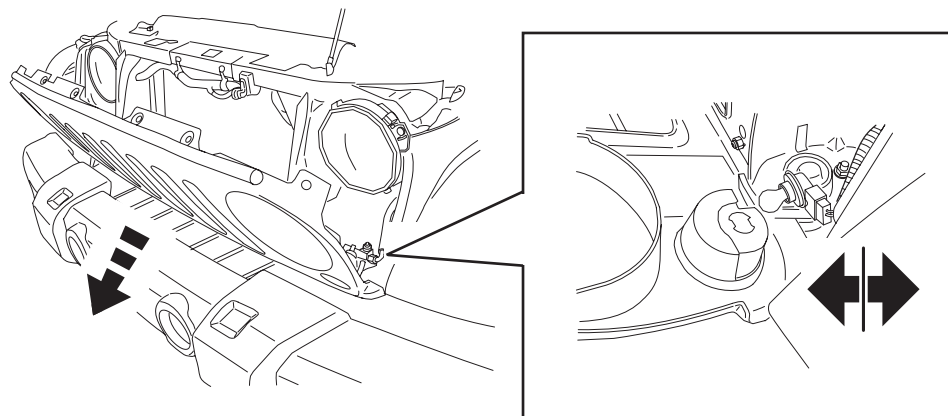

Disconnect bulb assembly on each side.

2

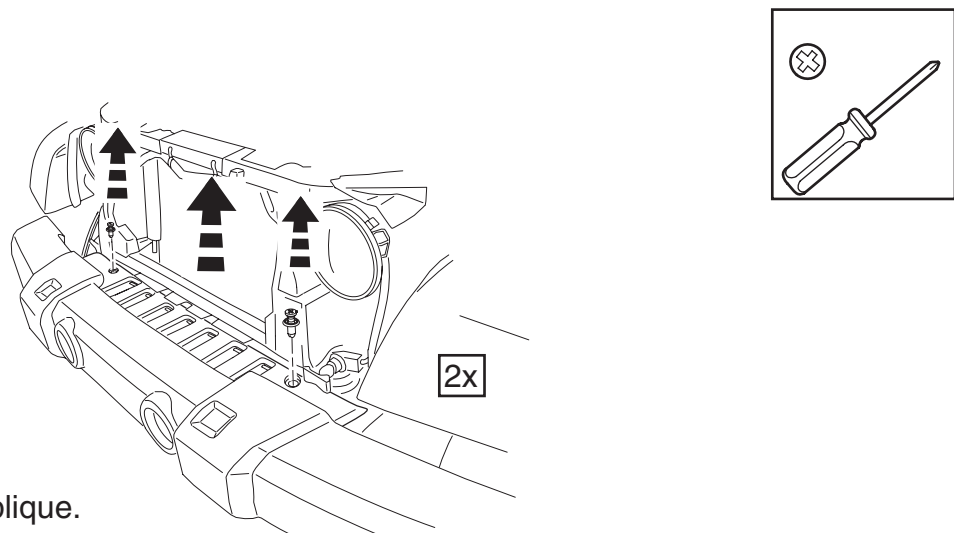

Remove bumper applique.

3

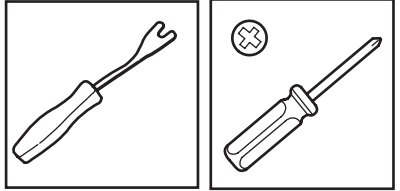
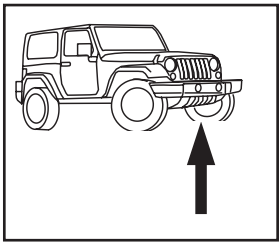
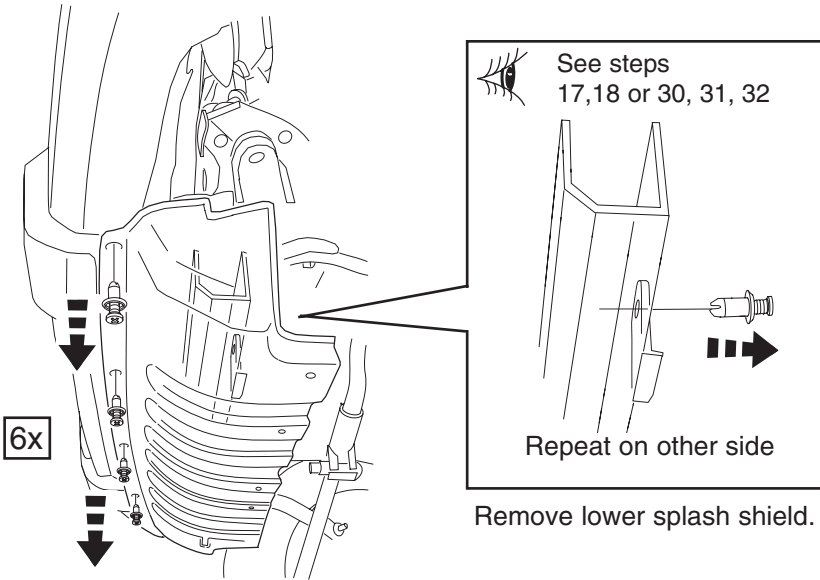

Remove lower splash shield.

4

See steps 12, 14, 22 & 24

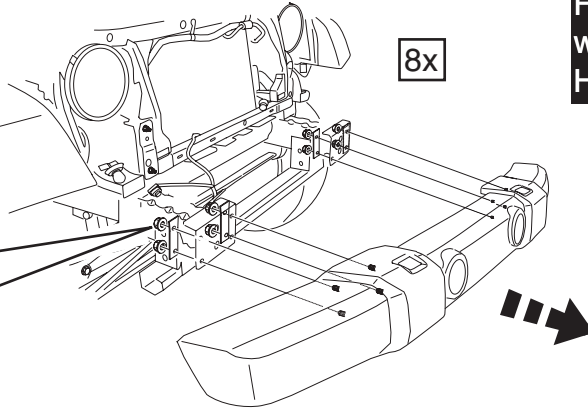
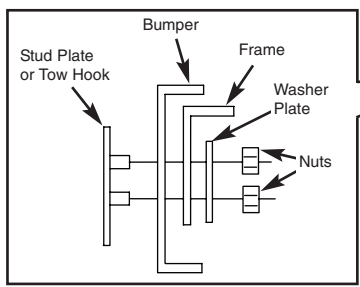

Fascia shown without Tow Hooks

*Note: Additional Fog Lamp Kits, Driving Lamp Kits and Wiring Installation Kits are available to be added to the holes provided in the bumper.

Save nuts & washer plates for re-use in steps 12, 14, or 22, 24.

5

Disconnect harness from fog lamp if equipped and place fascia assembly on the floor.

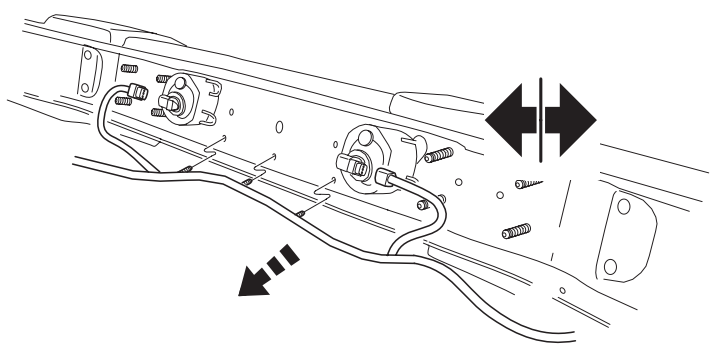
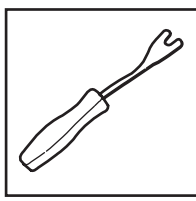

6

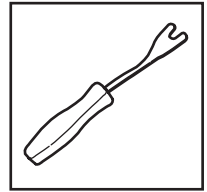
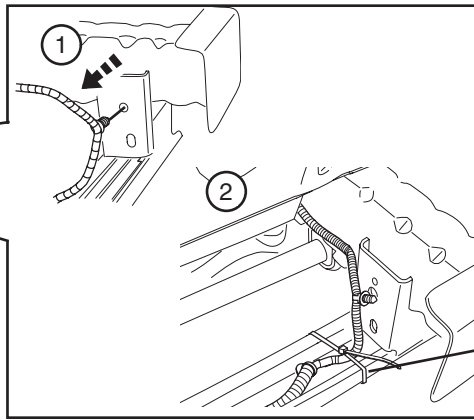
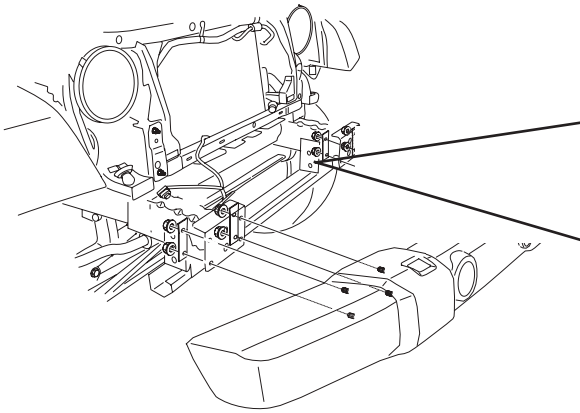

K
2x

1) Disconnect wire harness.
2) Using Item K, tie wrap securely in place to vehicle on both sides.

7

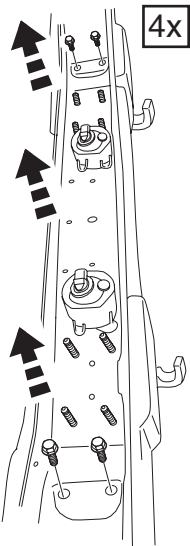

4x

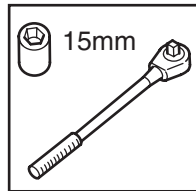

15mm

Remove crossmember to access stud plates. If equipped, remove tow hooks.

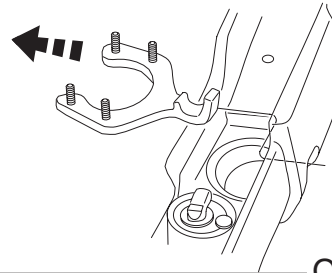

See step 14

Fascia with
Tow Hooks

OR



See step 12

Fascia without
Tow Hooks

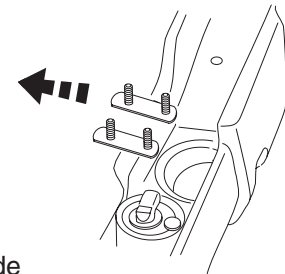

8

9

Repeat on other side

82211715, 82211715AC & 82211716, 82211716AC Only



See step 11

Remove fog Lamps from bumper

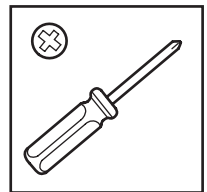
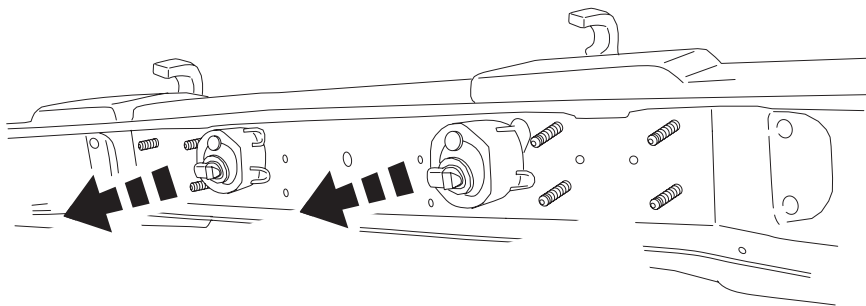

Remove 4 screws that secure front fog lamp housing to back of front bumper. Discard screws.

10

Install fog Lamps to bumper & torque

3.9 N.m / 35 In-lbs

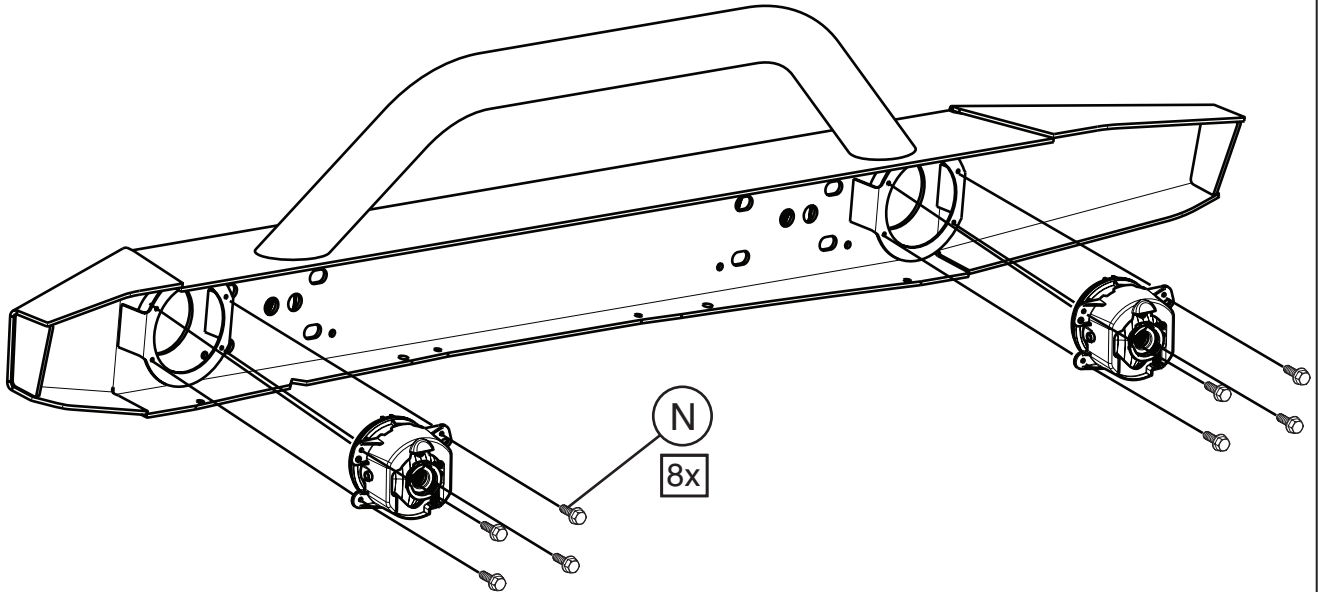
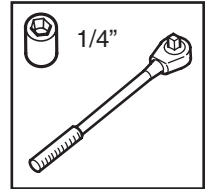

11

Kit # 82210341AC, 82211716AC & 82211716 (Shown) - Vehicle without Tow Hooks

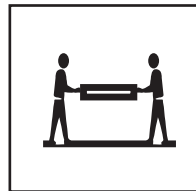
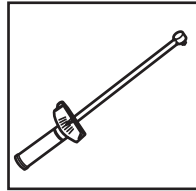
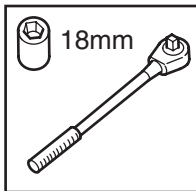
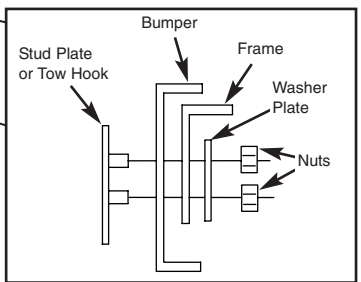
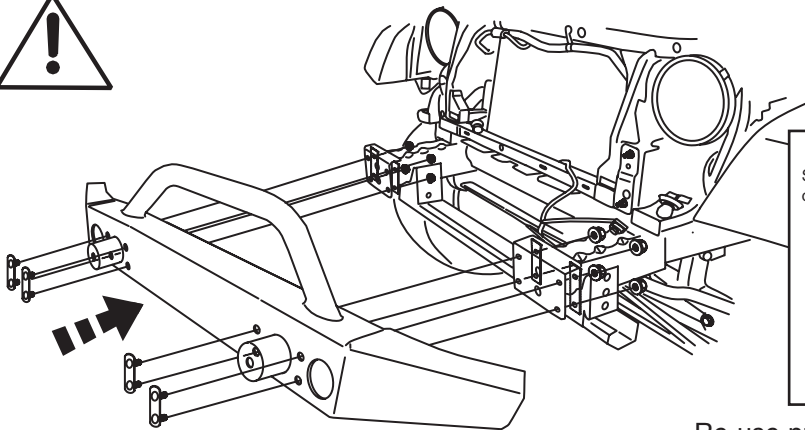

100 N.m / 75 ft-lbs

Re-use nuts and washer plates from Step 5 and stud plates from Step 9.

After leveling the bumper for best appearance, torque hardware as shown.

12

Vehicles without Tow Hooks, opening at bottom.

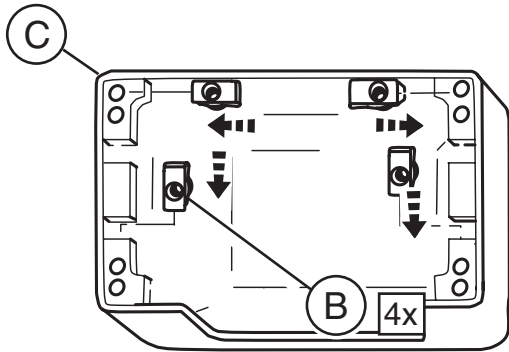

Install U-nuts as shown, correct orientation is important for proper installation.

13A

Do not over-torque
11 N.m / 96 in-lbs.

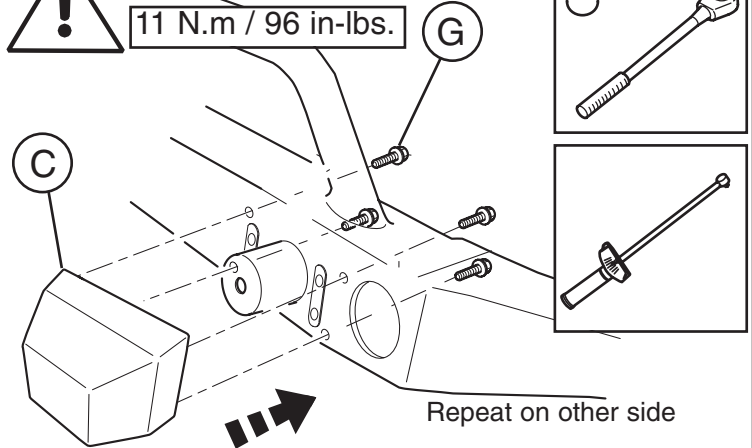

13B

Note: View without Tow Hook

Kit # 82210341AC, 82211716AC & 82211716 (Shown) - Vehicle with Tow Hooks



Vehicles with Tow Hooks

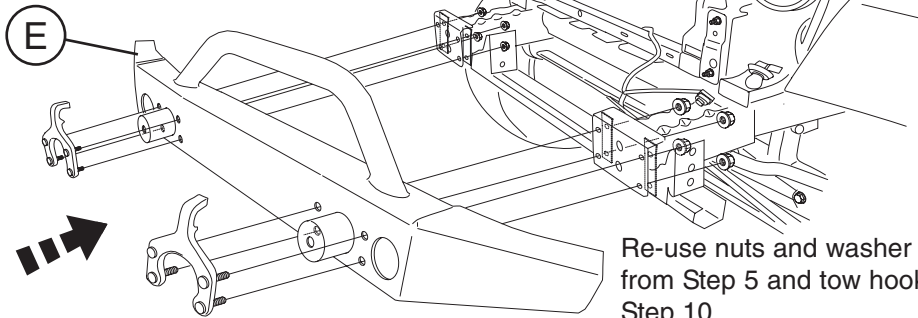

Re-use nuts and washer plates from Step 5 and tow hooks from Step 10.

14

100 N.m / 75 ft-lbs

After leveling the bumper for best appearance, torque hardware as shown.

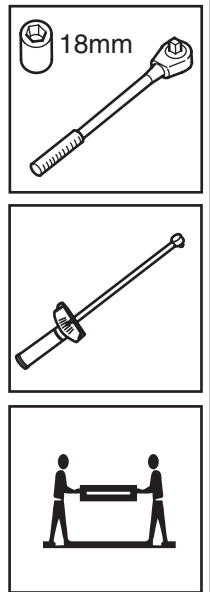

Vehicles with Tow Hooks, opening at top.

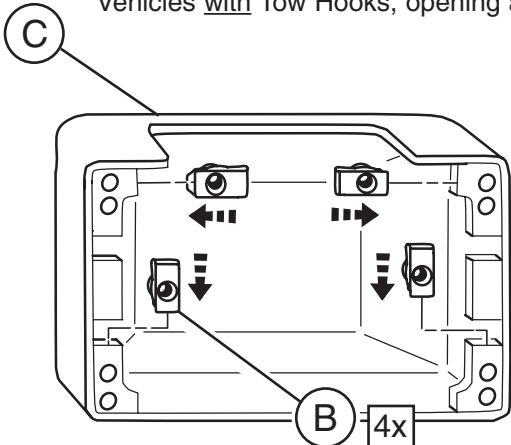

Install U-nuts as shown, correct orientation is important for proper installation.

15A

Do not over-torque
11 N.m / 96 in-lbs.

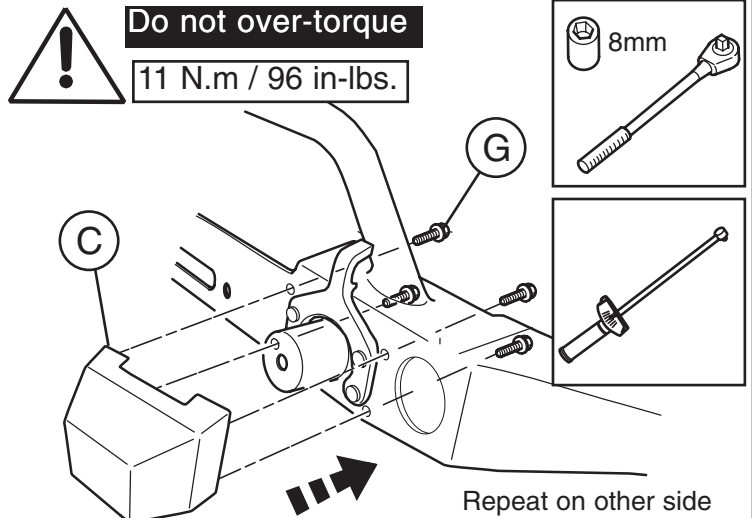

15B

Note: View with Tow Hook

Modify jumper harness and connect fog lamps & wire harness

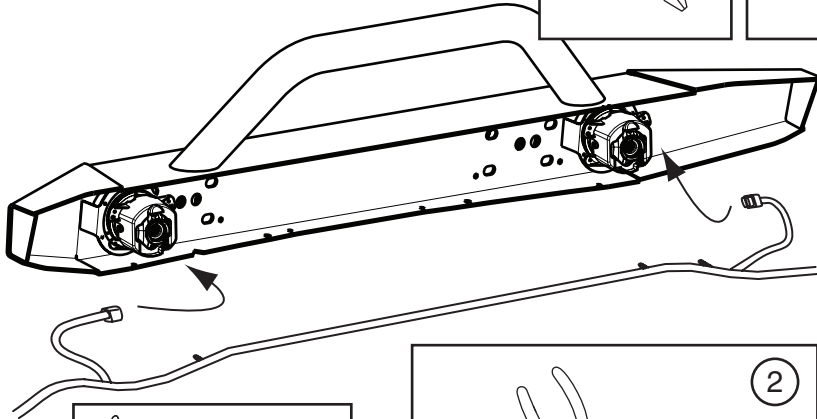
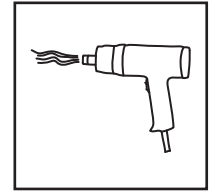
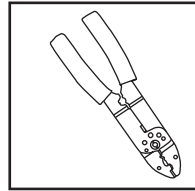
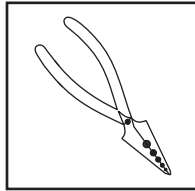
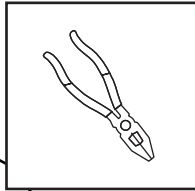

1) Pull back convoluted tubing near the connector. Cut the two wires 3 inches back from the connector.

2) Strip all four wire ends .30".

3) Using harness (Item O), crimp the White wire on the harness to each stripped ends of the White wire on the vehicle harness. Repeat process using the Black wire on the harness and vehicle harness.

4) Using a Heat Gun, shrink the butt connectors to the wires. Replace any convoluted tubing. Place provided convoluted tubing over the spliced wires.

5) Repeat process for other side of harness.

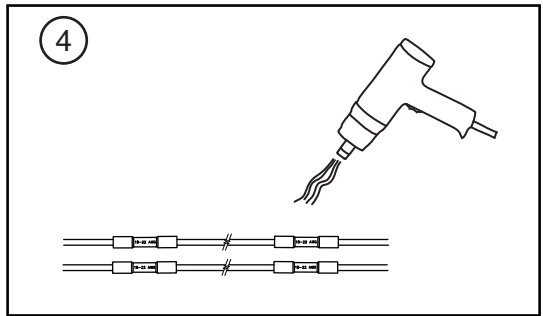
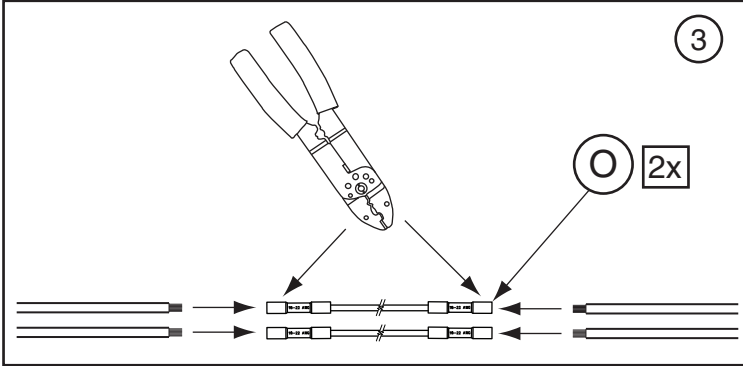
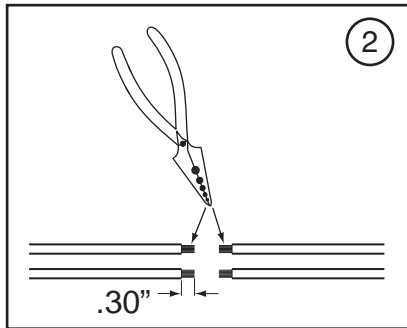
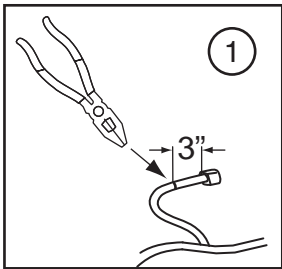

16

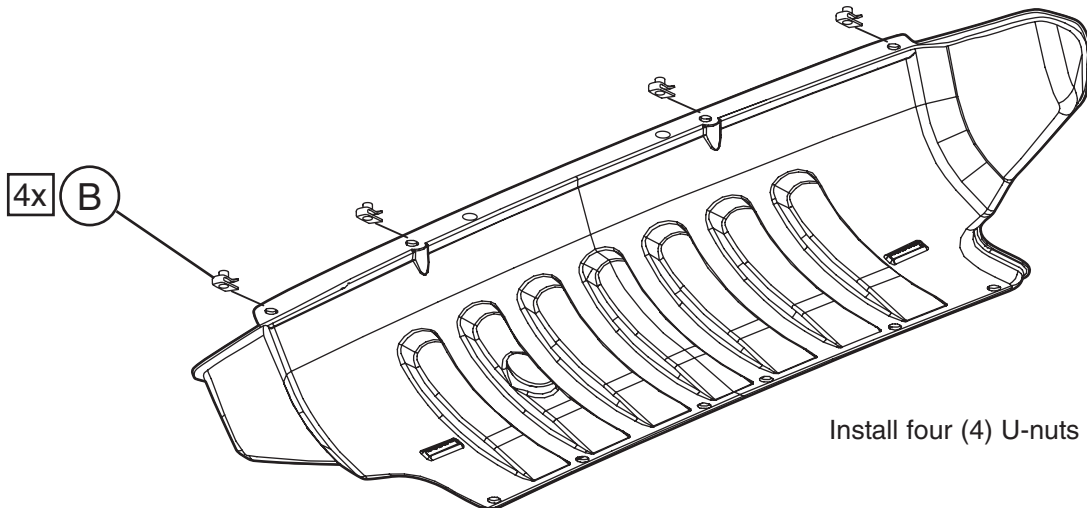

Install four (4) U-nuts (item B).

17

Kit # 82210341AC,
82211716AC &
82211716 (Shown)

12 N.m / 8 ft-lbs

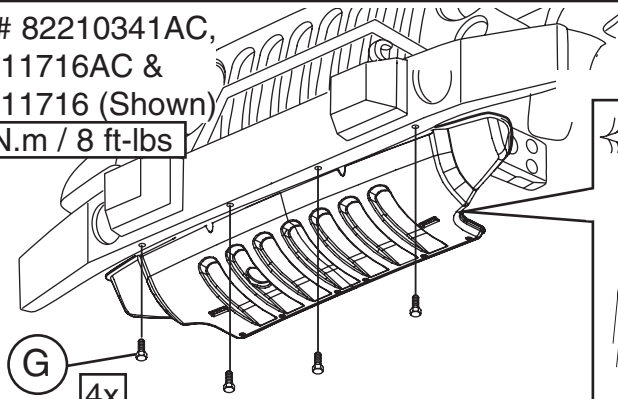

18

Splashshield is designed to be positioned above rear bumper flange.

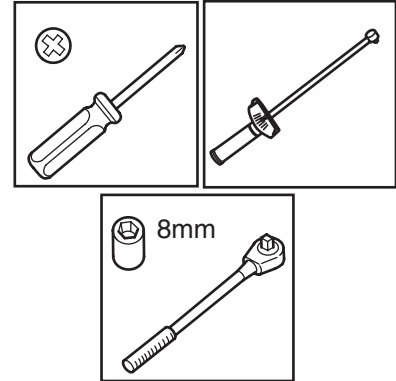
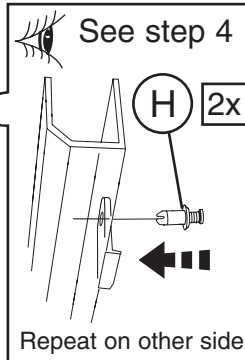

Kit # 82209740AD, 82211715 & 82211715AC (Shown)

19

See steps 1-3 Reverse Steps 3, 2 then 1 for re-installation of Grill Panel and Bumper Applique.

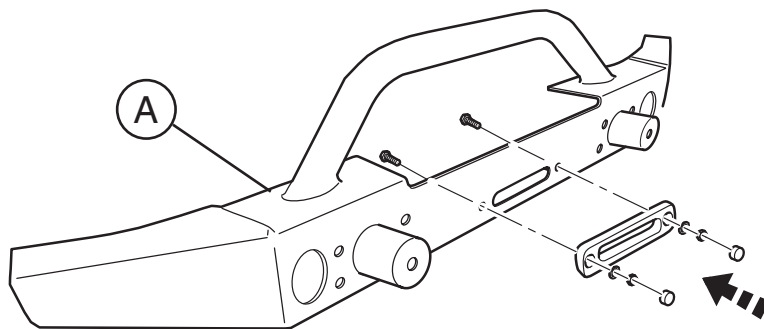

20

Hawse Fairlead and hardware not included in Bumper Kit # 82209740AD, 82211715 & 82211715AC.

Kit # 82209740AD, 82211715 & 82211715AC (Shown)

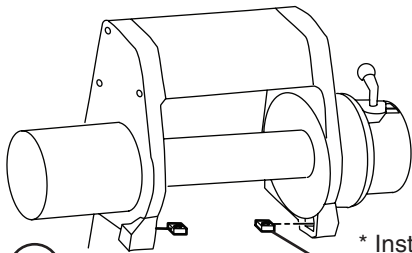

Winch must be positioned into bumper before the bumper is attached to the vehicle.

* Install 3/8" Square Nut (4x) *

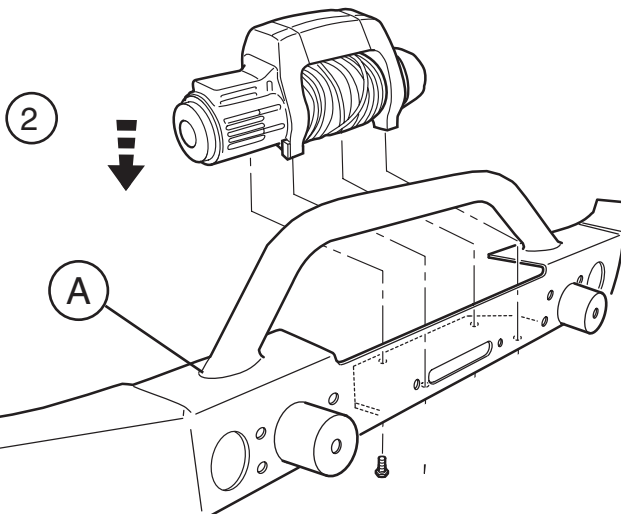

21

Note: If installing winch, rest winch in place, do not install bolts (item J). It will be necessary to move winch (side to side) to install bumper hardware.

Winch not included in Bumper Kit # 82209740AD, 82211715 & 82211715AC (Shown).

* 3/8" Square Nuts included in winch kit. The 3/8" bolts in winch kit will not be used. *

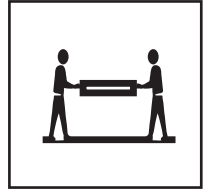

HAND TIGHTEN ONLY

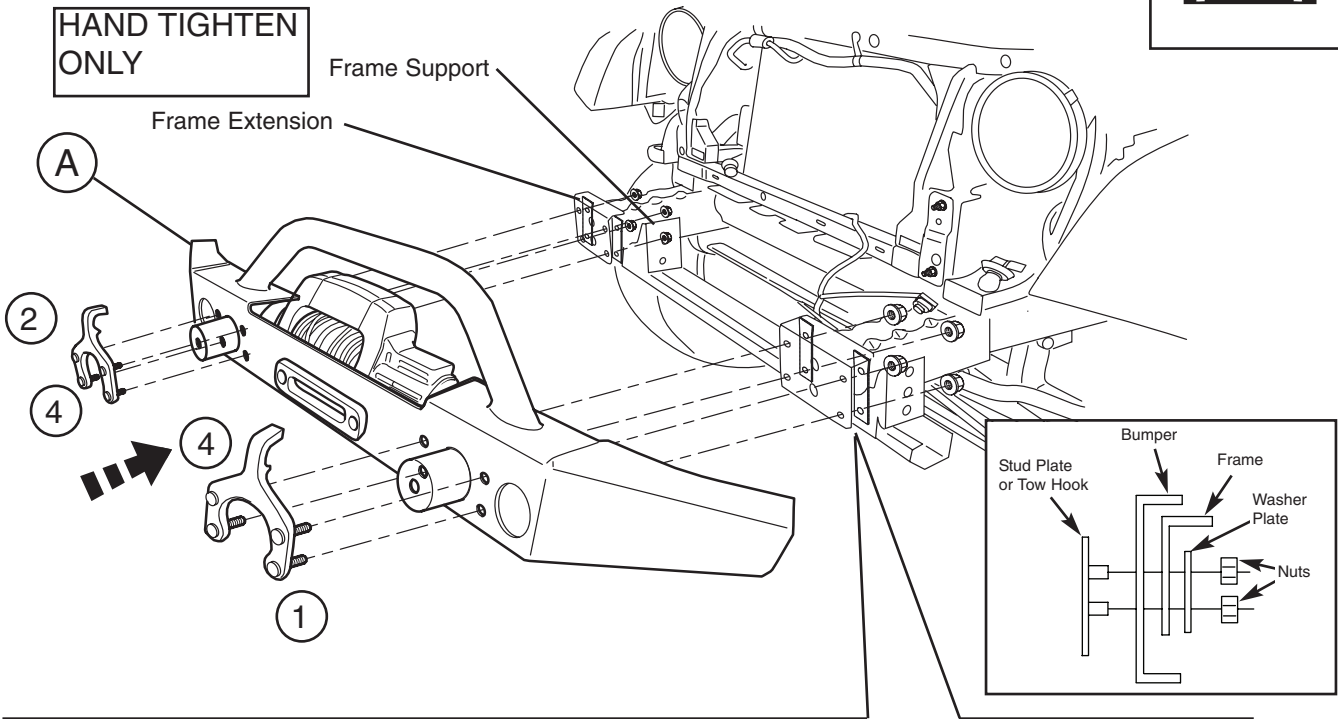

*Note: Due to vehicle variations, gaps may be present between the Lower Rear Bumper Bracket and the Frame Support. If gaps are present, install washers (item D, up to 2x per side) between the Lower Rear Bumper Bracket and the Frame Support.

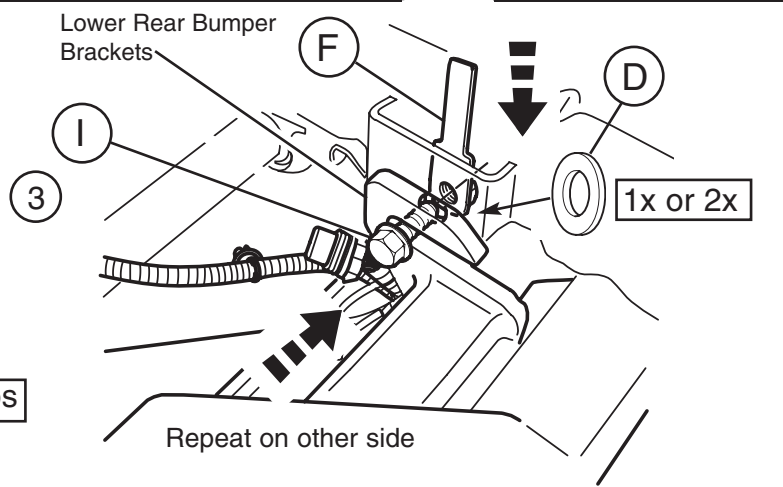

Rotate Bumper under frame extension to align lower rear bumper bracket slots to frame support hole (see frame 7) and then loosely install two tow hooks with nuts and washer plates (removed in step 5). Now loosely install bolts (item I) to handle nuts (item F). Due to vehicle variations, washers (item D) are supplied to eliminate gaps.

Vehicles without
Tow Hooks

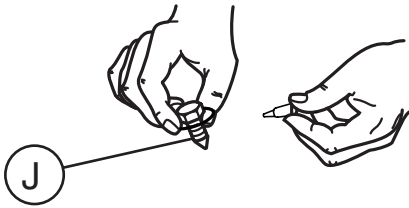

Apply Loctite to Bolts (Item J), 4
total.

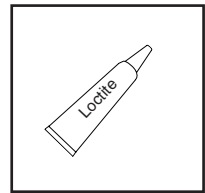

23

Vehicles without
Tow Hooks



8x 100 N.m / 75 ft-lbs

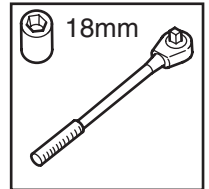
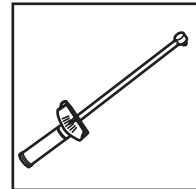
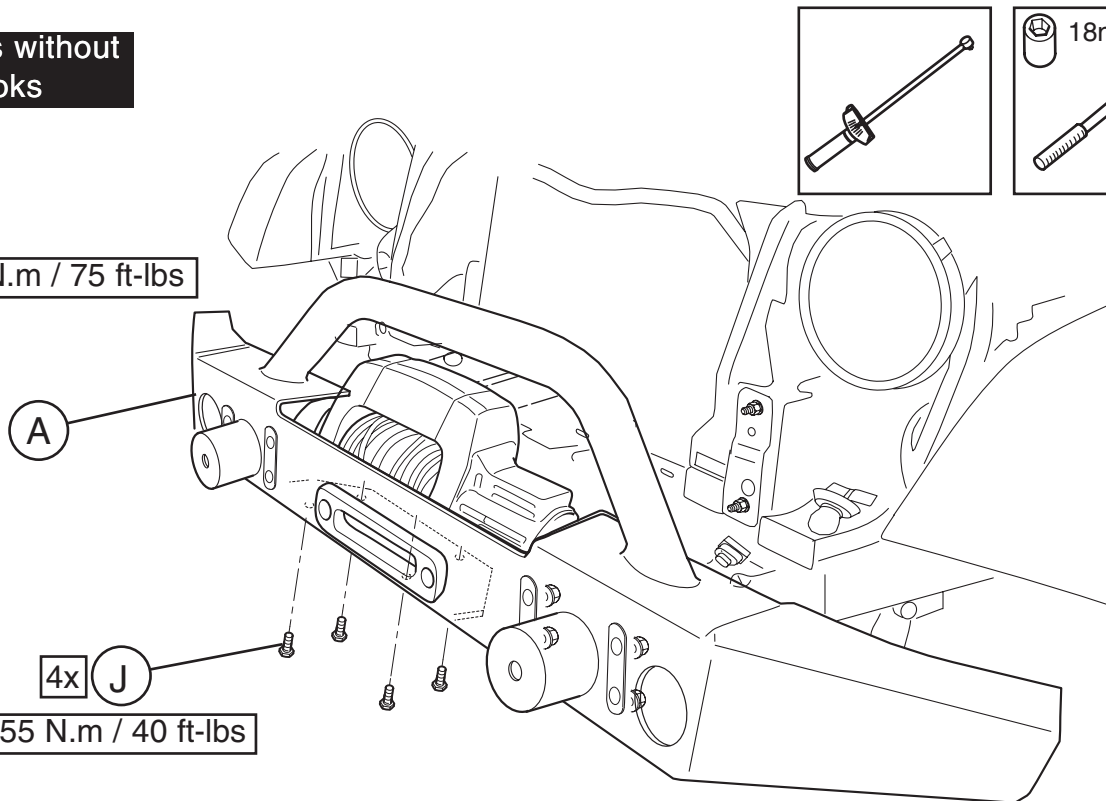

4x J
55 N.m / 40 ft-lbs

After leveling the bumper for best appearance, torque hardware as shown 8
places.

Install Winch using bolts (Item J) provided.

Note: If bolts do not align to nuts in the winch legs, the holes in bumper may need
to be enlarged slightly. If this procedure is required, deburr the holes/slots and
apply Mopar Rust Inhibitor 82300508 to all bare edges and allow to dry.

24

Vehicles with
Tow Hooks

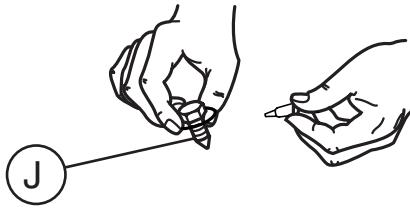

Apply Loctite to Bolts (Item J), 4
total.

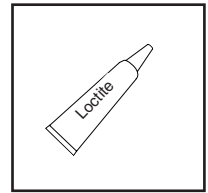

25

Vehicles with
Tow Hooks

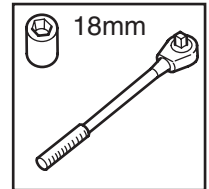
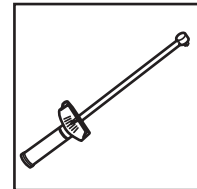

8x 100 N.m / 75 ft-lbs

A

4x J

55 N.m / 40 ft-lbs

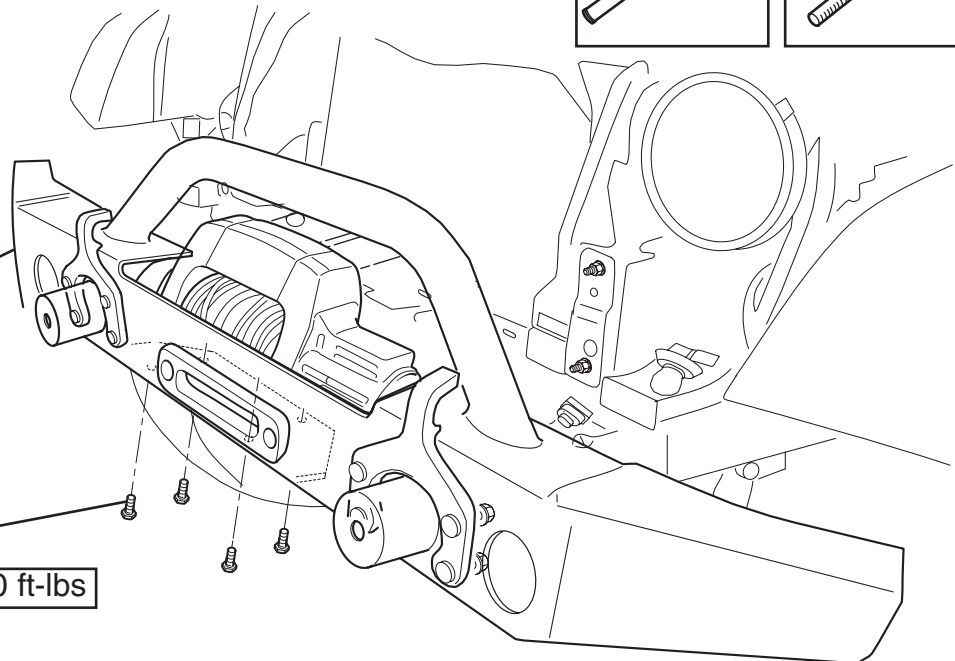

After leveling the bumper for best appearance, torque hardware as shown 8
places.

Install Winch using bolts (Item J) provided.

Note: If bolts do not align to nuts in the winch legs, the holes in bumper may need
to be enlarged slightly. If this procedure is required, deburr the holes/slots and
apply Mopar Rust Inhibitor 82300508 to all bare edges and allow to dry.

26

C Vehicles with Tow Hooks, opening at top.

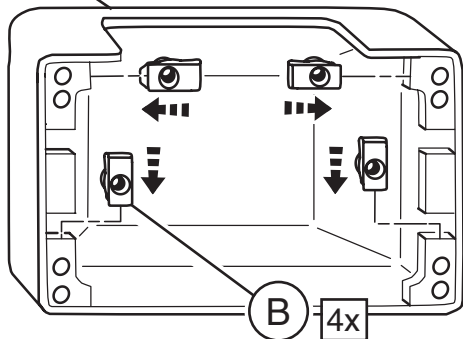

27 Install U-nuts as shown, correct orientation is important for proper installation.

C Vehicles without Tow Hooks, opening at bottom.

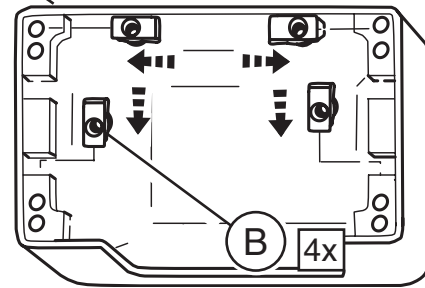

Install U-nuts as shown, correct orientation is important for proper installation.



11 N.m / 96 in-lbs.

Do not over-torque

Repeat on other side

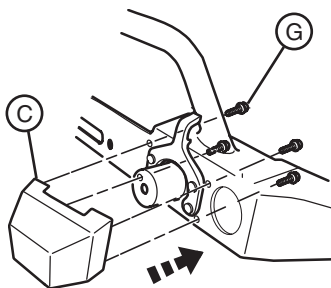

Note: View with Tow Hook

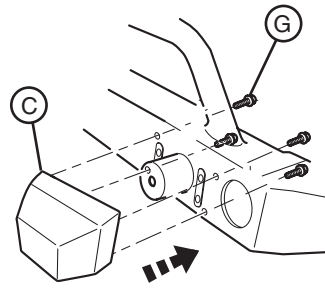

Note: View without Tow Hook

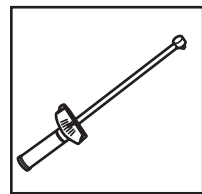
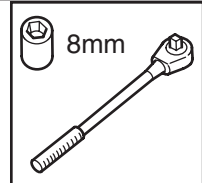

28

Modify jumper harness and connect fog lamps & wire harness

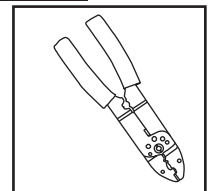
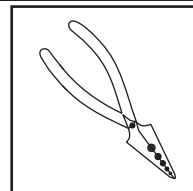
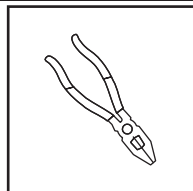
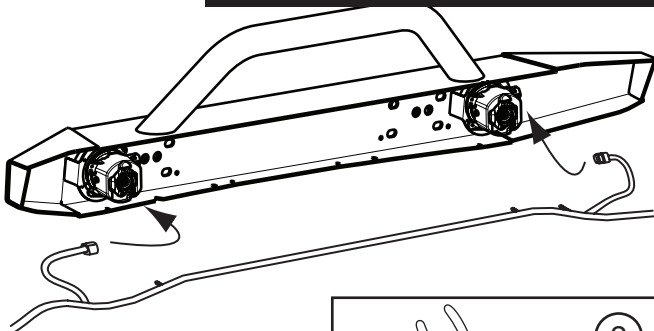

1) Pull back convoluted tubing near the connector. Cut the two wires 3 inches back from the connector.

2) Strip all four wire ends .30".

3) Using harness (Item O), crimp the White wire on the harness to each stripped ends of the White wire on the vehicle harness. Repeat process using the Black wire on the harness and vehicle harness.

4) Using a Heat Gun, shrink the butt connectors to the wires. Replace any convoluted tubing. Place provided convoluted tubing over the spliced wires.

5) Repeat process for other side of harness.

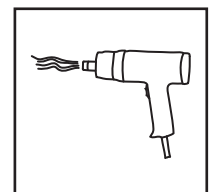
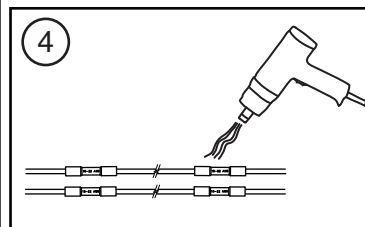
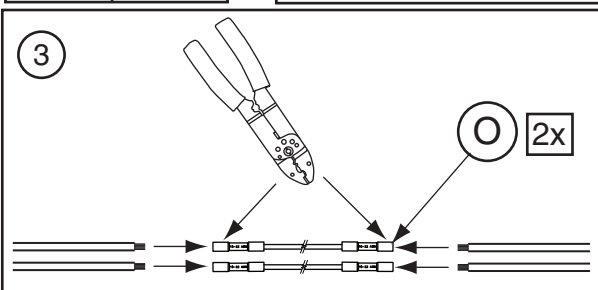
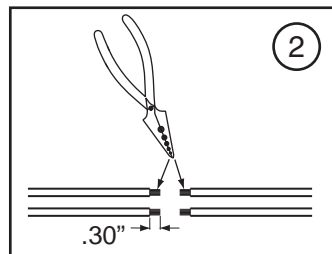
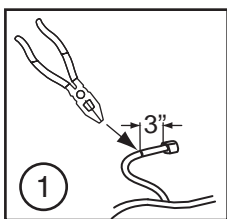

29

Kit # 82209740AD,
82211715 &
82211715AC

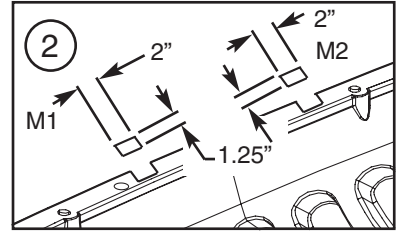
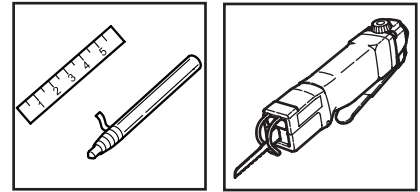
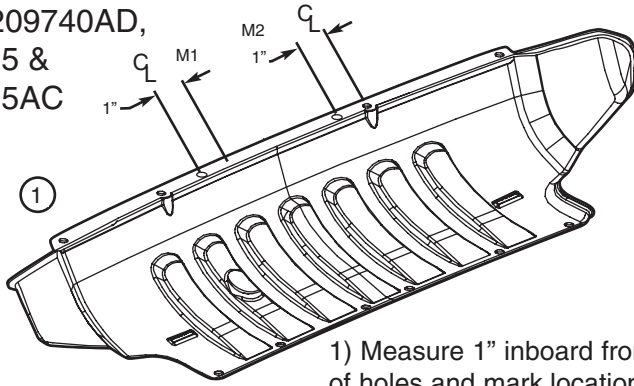

- 1) Measure 1" inboard from centerline of holes and mark locations (M1 and M2).
- 2) Notch locations 2" wide and 1.25" deep.

30

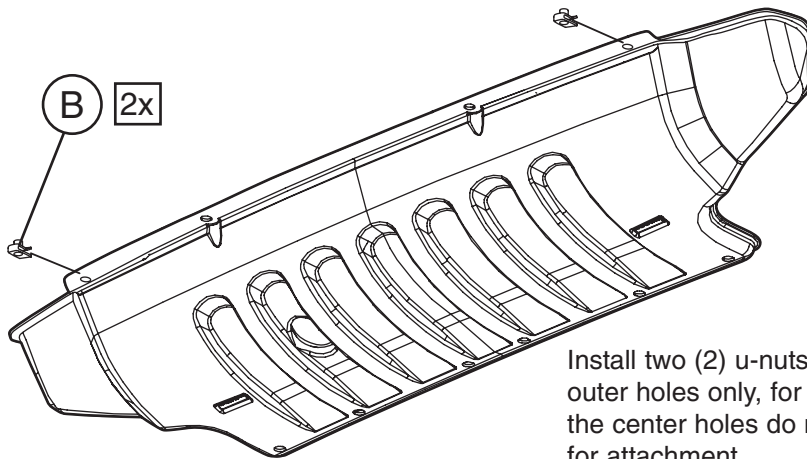

Install two (2) u-nuts (item B) to the outer holes only, for the Winch Bumper the center holes do not require u-nuts for attachment.

31

Kit # 82209740AD,
82211715AC &
82211715 (Shown)

12 N.m / 8 ft-lbs

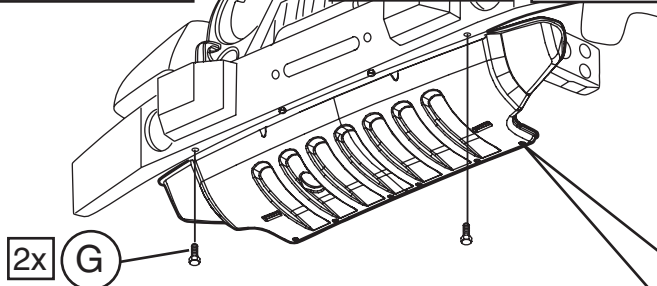
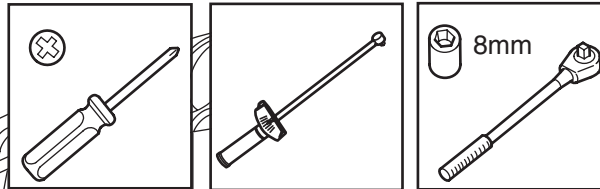

Splashshield is designed to be positioned above rear bumper flange. Outer holes (2) are used to attach splashshield.

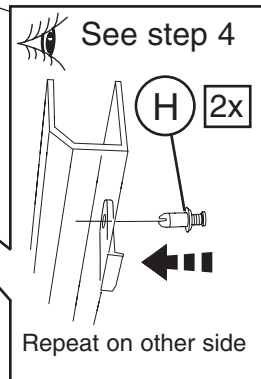

32

See steps 1-3

Reverse Steps 3, 2 then 1 for re-installation of Grill Panel and Bumper applique

33