

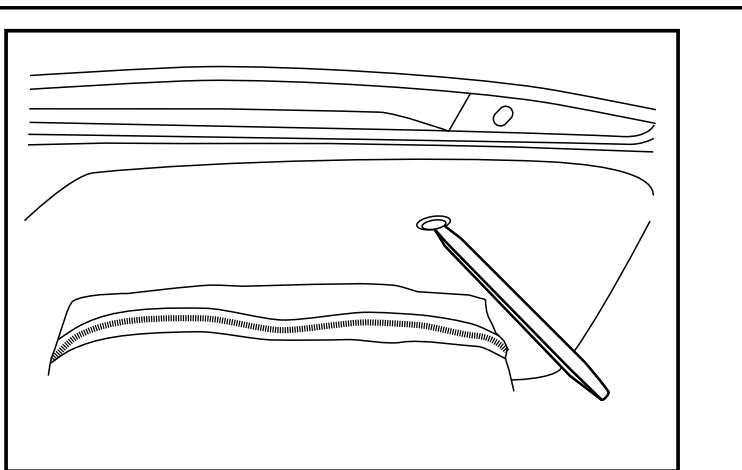

Fiat 124 Spider/Abarth Convenience Net

Filet d'arrimage/Bequemlichkeit netto/Rete di carico/Red de carga

www.mopar.com

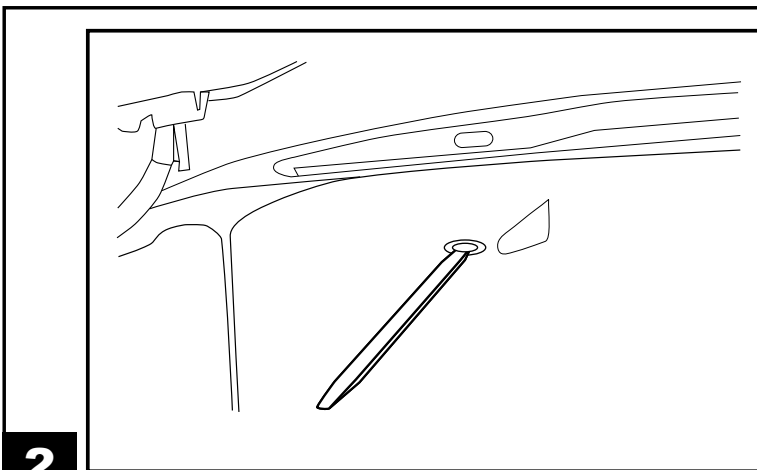
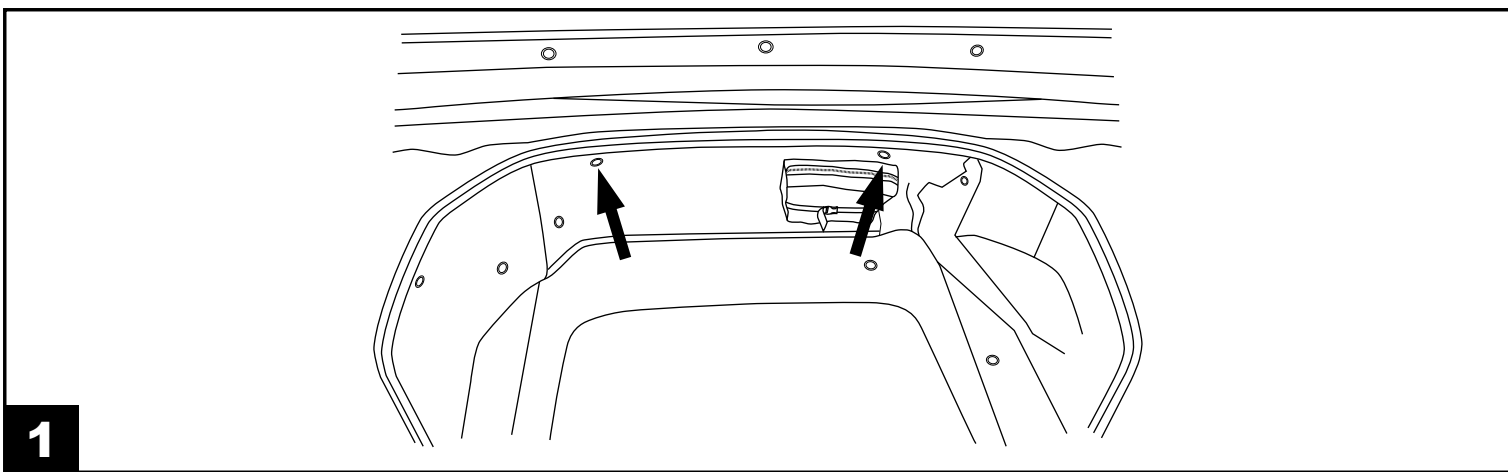
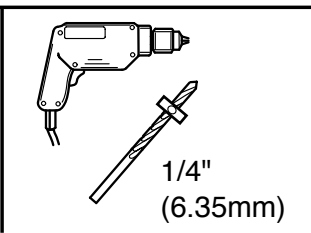
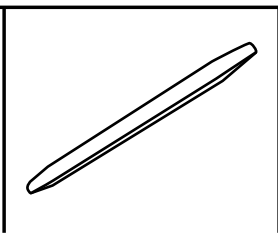
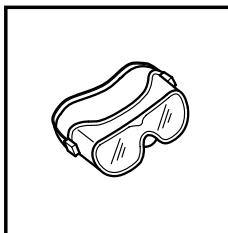
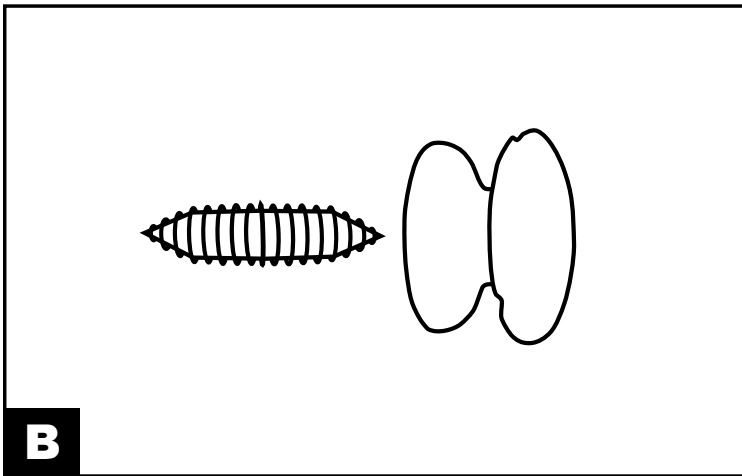
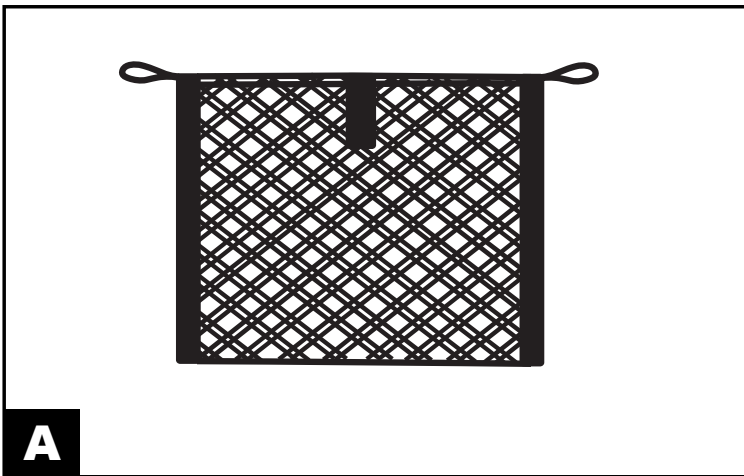

2



Fiat 124 Spider/Abarth Convenience Net

Filet d'arrimage/Bequemlichkeit netto/Rete di carico/Red de carga

www.mopar.com

3

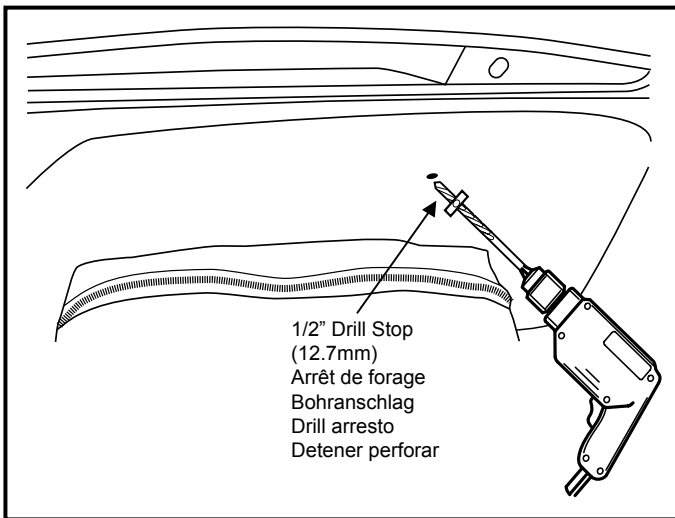
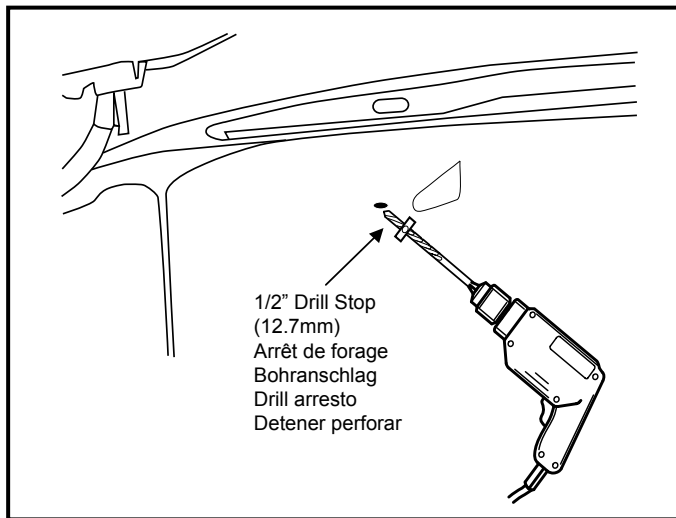

4

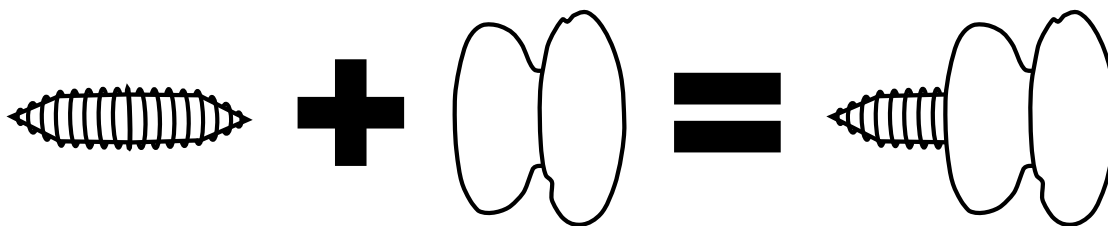

5

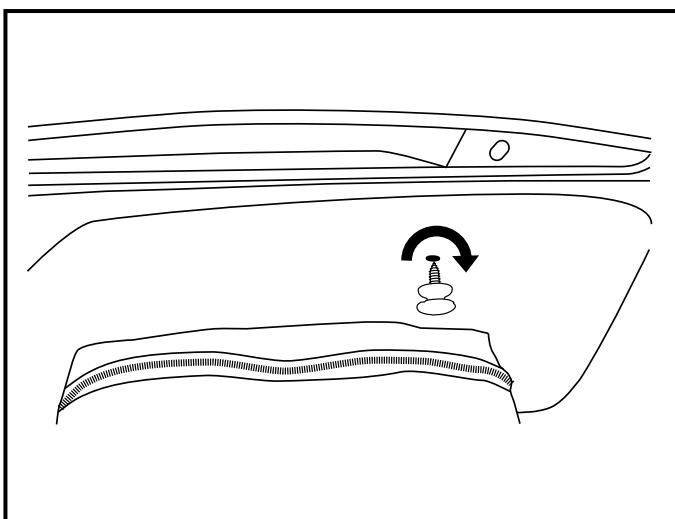
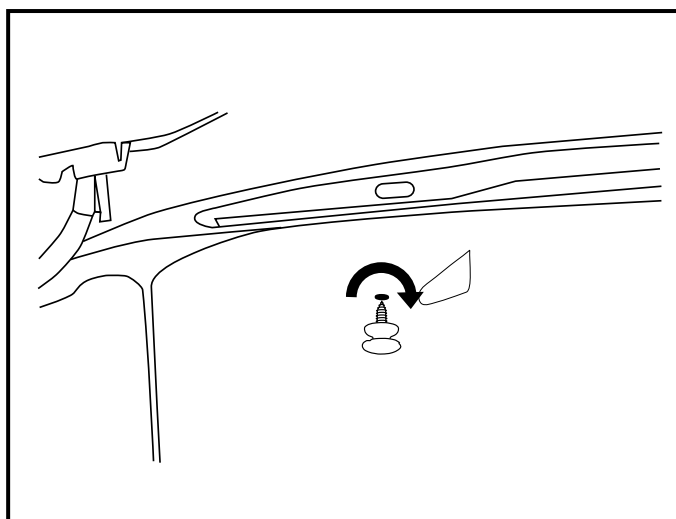



Fiat 124 Spider/Abarth Convenience Net

Filet d'arrimage/Bequemlichkeit netto/Rete di carico/Red de carga

www.mopar.com

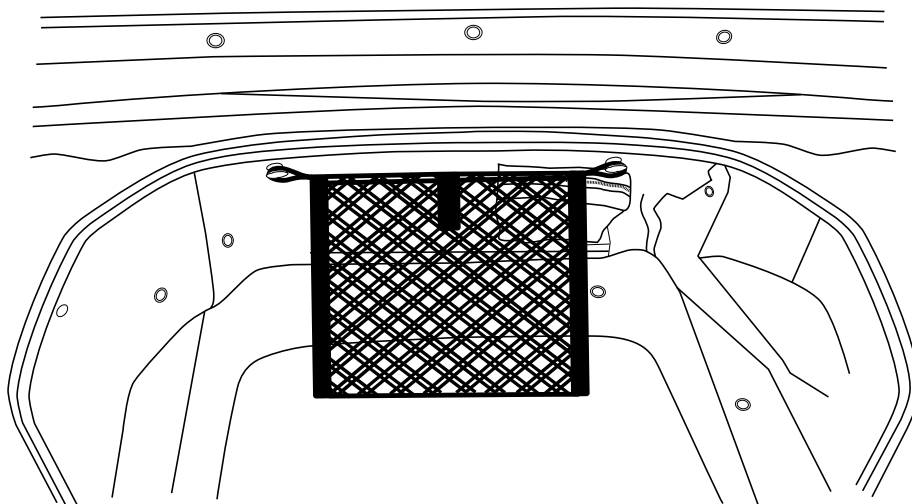

6