

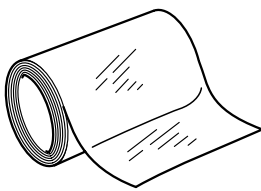

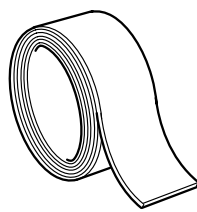





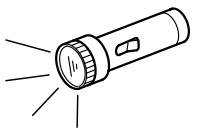
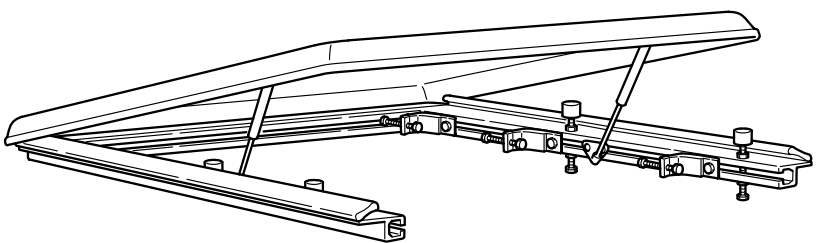
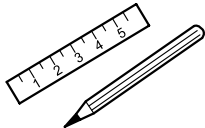
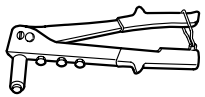

FOR TECHNICAL ASSISTANCE, SERVICE REPLACEMENT PARTS OR
CUSTOMER SERVICE CALL: 1-800-533-0450 X160 OR 1-507-695-2378 X160

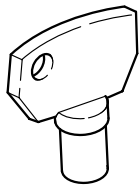
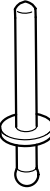
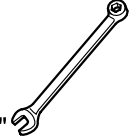
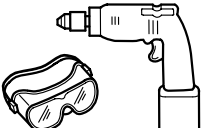
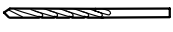
DODGE RAM Tonneau Cover

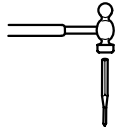
NO TONNEAU IS 100% WATERPROOF - This tonneau has been rigorously tested under various types of car wash systems with minimal water entry.

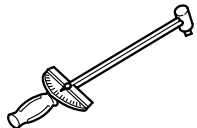
 <p>A</p>	 <p>B</p>	 <p>ELECTRICAL TAPE</p>	
 <p>C</p>			
 <p>D</p>  <p>E 2x</p>  <p>F 2x</p>		<p>5/16" 7/16" 1/2" 9/16" 11/16"</p> 	
		 <p>3/16" (4.7mm)</p>	
			
		<p>RUST INHIBITOR</p>  <p>82300508</p>	

GB

NOTE: DO NOT INSTALL TONNEAU COVER WITH AN OVER THE RAIL BED LINER.

PREVENTIVE MAINTENANCE

- After a setting period (500 mile maximum), it may be necessary to readjust the pawl position, and/or the bumpers to maintain the uniform gap between the Tonneau Cover and bed rails to prevent the lids from scratching them.
- After a setting period (500 mile maximum), it will be necessary to check the security on all bolts.
- Check the torque specifications of the attaching hardware every 6 months or 5,000 miles.
- Lubricate the latch contact surfaces and key cylinder annually with a white lithium spray grease #04318066.

USAGE AND CARE

- Do not remove the Tonneau Cover from the hinge system. To remove the Tonneau Cover from the vehicle, loosen the 5/16" bolts and lock nuts on the J-brackets and remove the whole unit.
- Do not drive vehicle while Tonneau Cover is open. The Tonneau Cover must be locked while the vehicle is in motion.
- Do not load any measurable weight onto the top of the Tonneau Cover. This will bend frame.
- Do not polish or wax for 90 days. Buffing is O.K. to remove scratches and abrasions. Note: Use Mopar touch-up paint for minor nicks and scratches.
- Do not wipe painted surface with dry cloth.
- Do not spill chemicals such as antifreeze and coolants on finish. If such a spill occurs, wipe it up immediately.
- Do not scrape ice and snow from painted surface, use warm water to remove.
- Do not use car washes with brush rollers: only use car washes that contain the soft wipe type.

Make sure to wash the Tonneau Cover in a shaded area using cool water and a Mild detergent.

If problems are encountered during installation, please call 1-800-533-0450 X160 OR 1-507-695-2378 X160

E

- **NOTA: NO INSTALE LA CUBIERTA DE LA CAPOTA POSTERIOR CON UN REVESTIMIENTO DE CAJA QUE PASE SOBRE EL LARGUERO.**

MANTENIMIENTO PREVENTIVO

- Luego de un periodo de asentamiento (de 500 millas como máximo), es posible que se deba reajustar la posición del fiador o las defensas para mantener una separación uniforme entre la cubierta de la capota posterior y los largueros de la caja para evitar que las tapas los raspen.
- Luego de un periodo de asentamiento (de 500 millas como máximo), será necesario verificar que todos los pernos estén bien ceñidos.
- Verifique que los herrajes de fijación cumplan las especificaciones de torsión cada 6 meses o 5000 millas.
- Lubrique las superficies de contacto del cerrojo y del cilindro de la llave una vez al año con grasa de litio blanca en pulverizador #04318066.

USO Y CUIDADO

- No retire la cubierta de la capota posterior tomándola del sistema de bisagras. Para retirar la cubierta de la capota posterior del vehículo, afloje los pernos de 5/16" y las contratruercas de los soportes en J y retire la unidad completa.
 - No conduzca el vehículo con la cubierta de la capota posterior abierta. La cubierta de la capota posterior debe estar bloqueada cuando el vehículo está en movimiento.
 - No cargue ningún peso significativo sobre la cubierta de la capota posterior. Podría torcer el bastidor.
 - No lustrar ni encerar por 90 días. Se puede pulir para eliminar arañazos y abrasiones. Nota: Utilice pintura para retoques Mopar para cubrir mellas y arañazos menores.
 - No limpie la superficie pintada con un paño seco.
 - No derrame sustancias químicas, tales como anticongelante o refrigerantes, sobre el acabado. Ante un derrame de este tipo, límpielo inmediatamente.
 - No raspe el hielo y la nieve de las superficies pintadas, utilice agua tibia para quitarlos.
 - No utilice lavacoches con rodillos: utilice sólo lavacoches con limpiadores suaves.
Asegúrese de lavar la cubierta de la capota posterior en un área sombreada utilizando agua fría y un detergente suave.
- Si tiene problemas durante la instalación, llame al **1-800-533-0450 X160 OR 1-507-695-2378 X160**

F

- **NOTE : NE PAS INSTALLER LE CACHE-CAISSE AVEC UNE DOUBLURE DE CAISSE SUR LE REBORD.**

MAINTENANCE PRÉVENTIVE

- Après une période d'ajustement (800 km/500 milles maximum), il peut s'avérer nécessaire de réajuster la position du cliquet et/ou les tampons pour maintenir l'écartement uniforme entre le cache-caisse et les rebords de caisse, et empêcher ainsi les couvercles de les rayer.
- Après une période d'ajustement (800 km/500 milles maximum), il sera nécessaire de vérifier tous les boulons.
- Vérifier la pression de serrage des pièces de fixation tous les 6 mois ou 8 000 km/5 000 milles.
- Lubrifier les surfaces de contact du système de verrouillage et du barillet de serrure tous les ans en vaporisant de l'huile au lithium blanche #04318066.

UTILISATION ET ENTRETIEN

- Ne pas déloger le cache-caisse de ses charnières. Pour l'enlever du véhicule, desserrer les contre-écrous et verrous 5/16 po. des consoles en J, puis retirer le tout.
- Ne pas conduire le véhicule lorsque le cache-caisse est ouvert. Ce dernier doit être verrouillé pendant tout déplacement du véhicule.
- Ne rien poser de lourd sur le cache-caisse sous peine de tordre le cadre.
- Ne pas appliquer de vernis ou de cire pendant 90 jours. Les éraflures ou traces d'abrasion peuvent être passées à la meule. Note : utiliser une peinture de retouche Mopar pour les petites entailles et éraflures.
- Ne pas essuyer les surfaces peintes avec un linge sec.
- Ne pas déverser de produits chimiques tels que liquides antigel ou de refroidissement sur les surfaces finies. En cas de déversement, essuyer immédiatement.
- Ne pas gratter le givre ou la neige sur les surfaces peintes. L'enlever à l'eau tiède.
- Ne pas laver le véhicule dans un lave-auto à brosses mécaniques : n'aller que dans les lave-autos munis de brosses douces.

Laver le cache-caisse dans un coin ombragé à l'eau froide avec un produit de nettoyage doux.

En cas de problème d'installation, appeler le **1-800-533-0450 X160 OR 1-507-695-2378 X160**

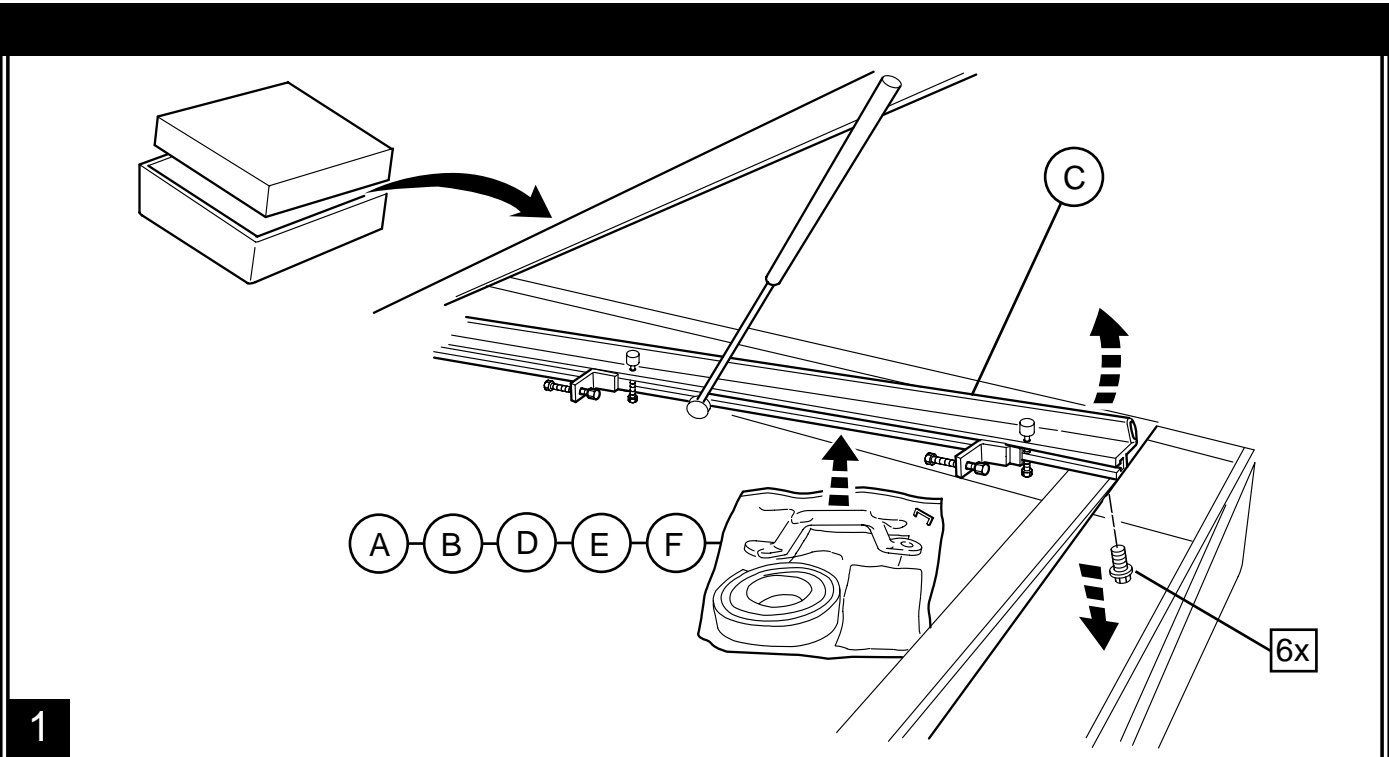

1

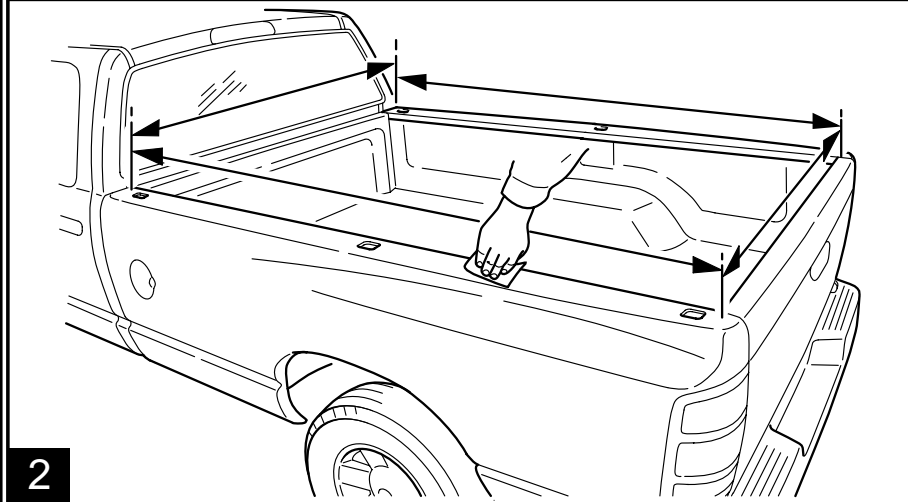

2

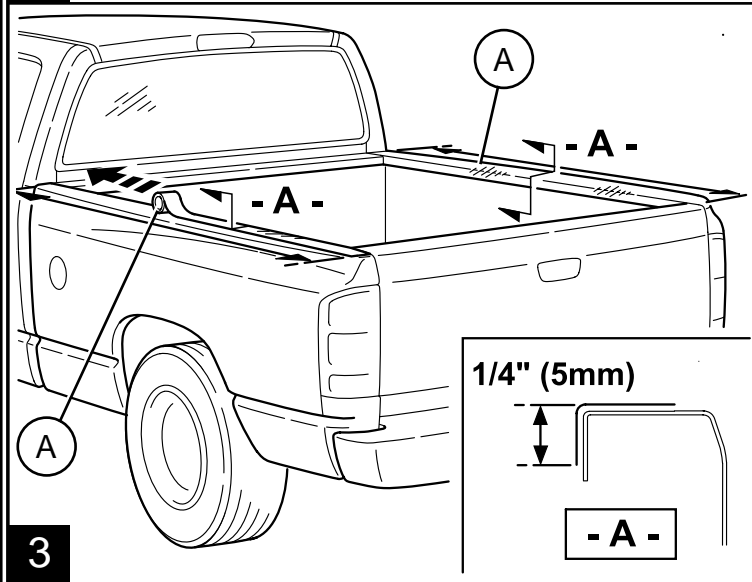

3

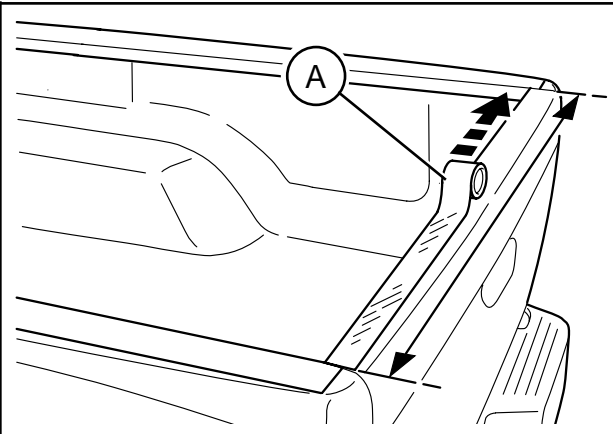

4

Trucks WITHOUT tailgate protector.
 Camionetas SIN protector de compuerta trasera.
 Camions SANS protecteur de hayon.

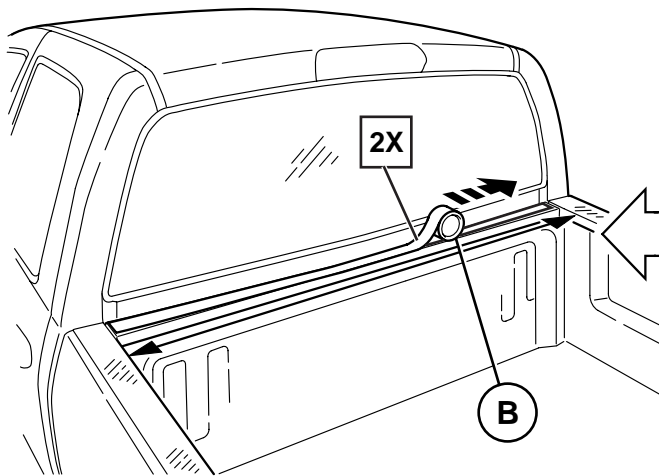

5

Apply to trucks **WITHOUT** bedliner -Double layer.
 Corresponde a las camionetas SIN camisa de caja.
 Pour camions **SANS** doublure de plate-forme.

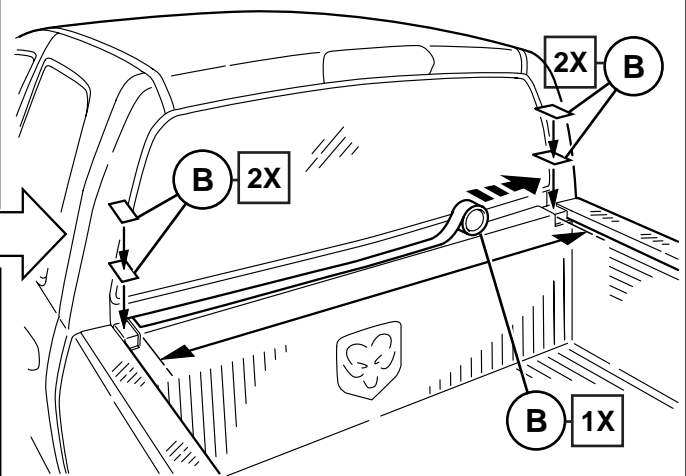

5A

Apply to trucks **WITH** bedliner as shown.
 Corresponde a las camionetas **CON** camisa de caja.
 Pour camions **AVEC** doublure de plate-forme.

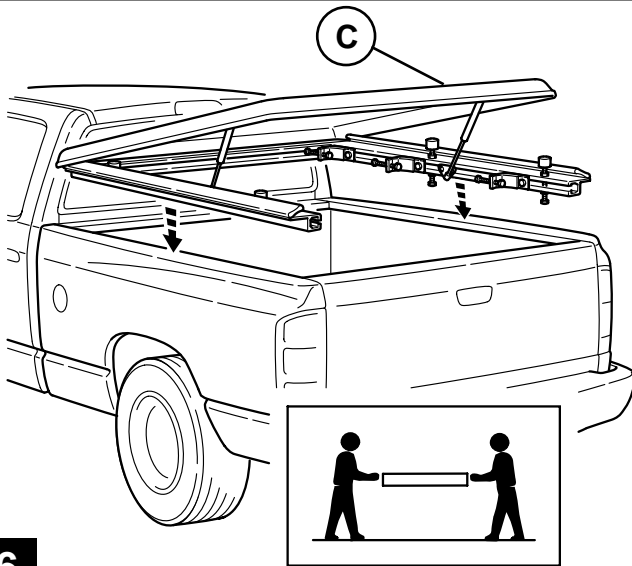

6

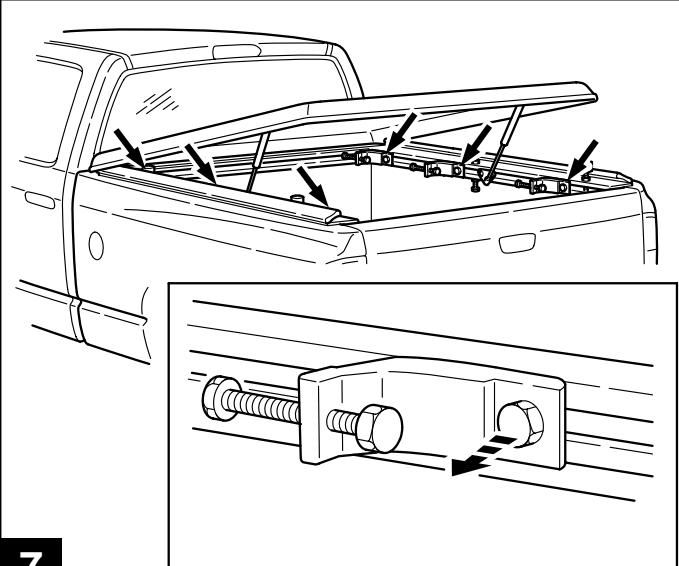

7

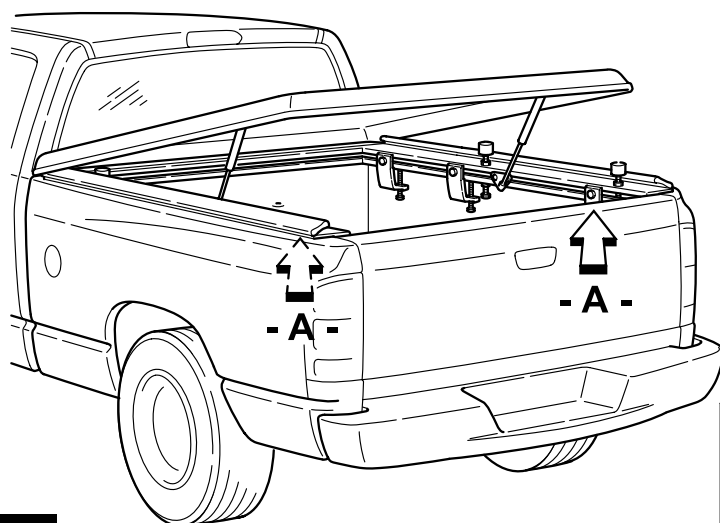

8

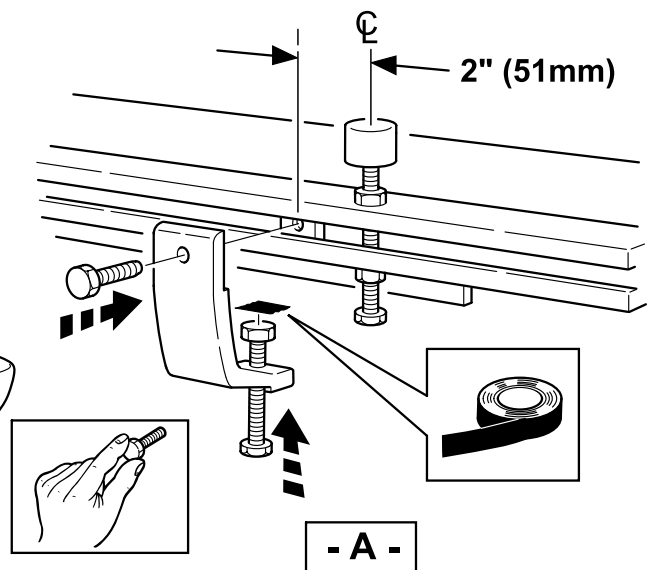

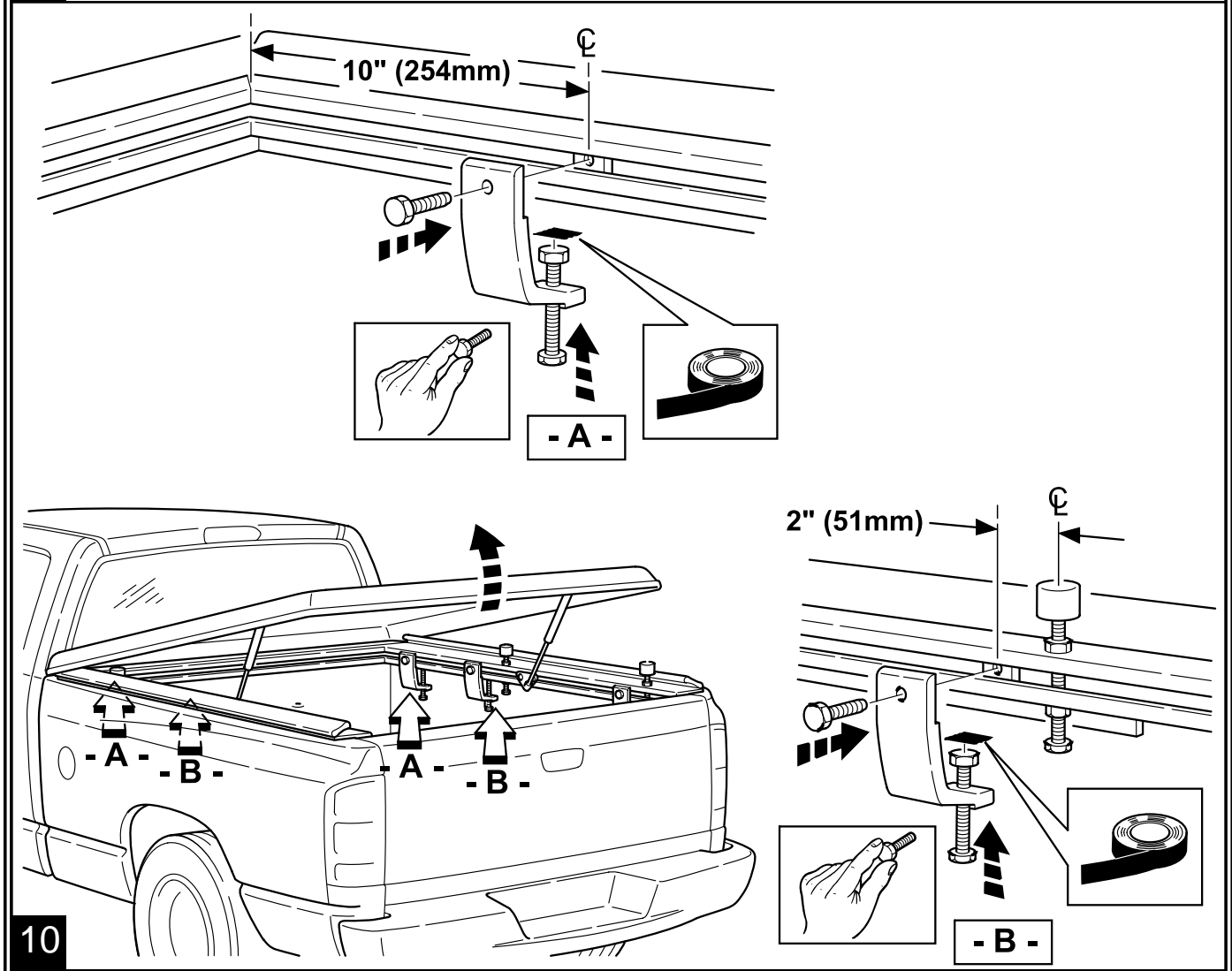
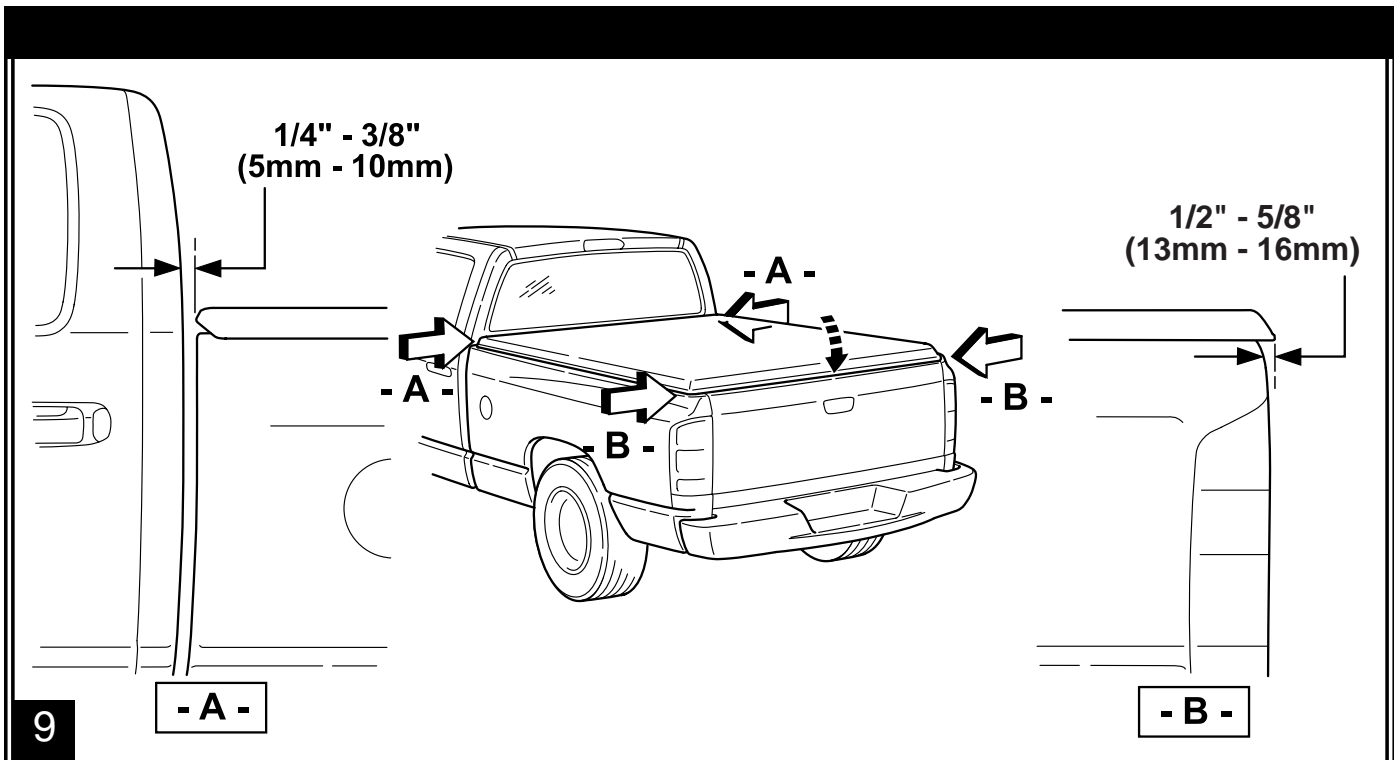

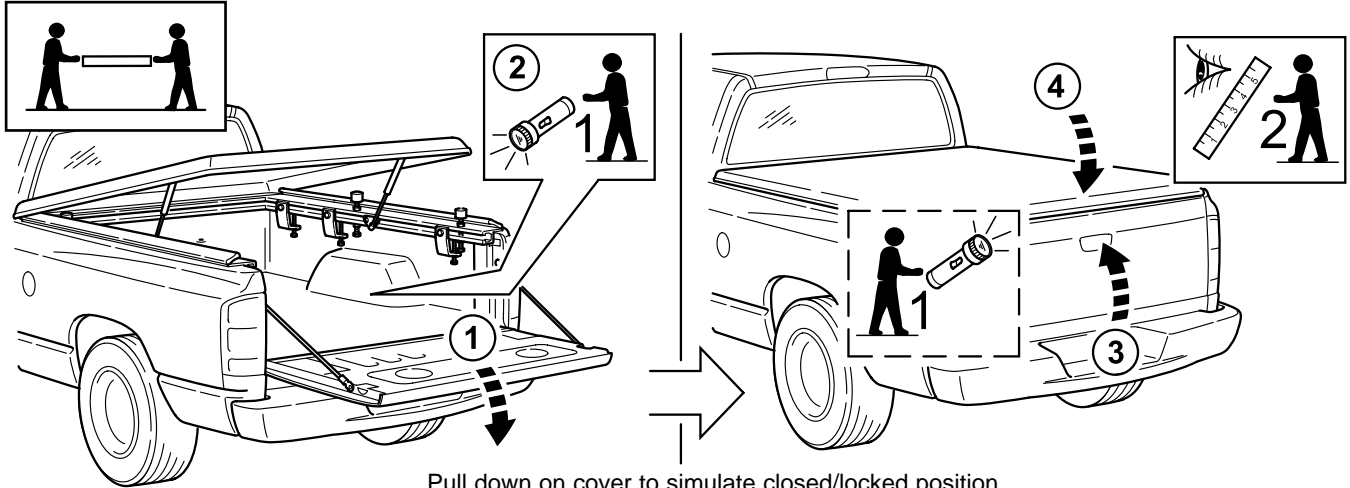

11

Pull down on cover to simulate closed/locked position.
 Tire hacia abajo de la cubierta para simular la posición cerrado/bloqueado.
 Tirer sur la couverture pour simuler la position fermée/verrouillée.

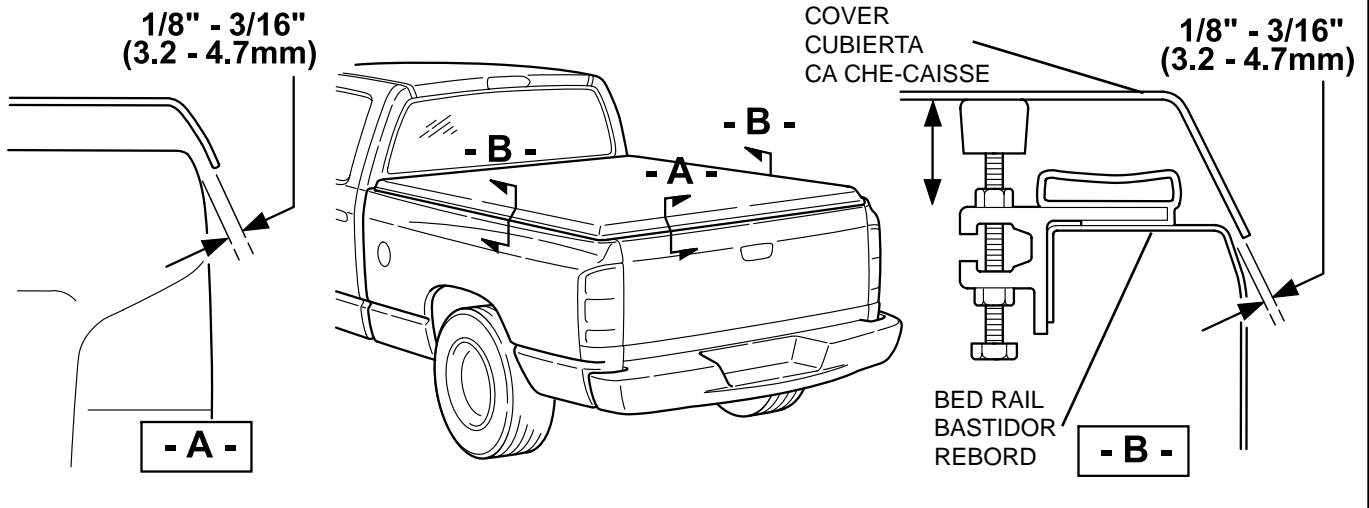

12

Adjust all four bumpers to attain uniform gap to the body.
 Ajuste las cuatro defensas para lograr una separación uniforme con la carrocería.
 Ajuster les quatre amortisseurs pour obtenir un espace uniforme avec la caisse.

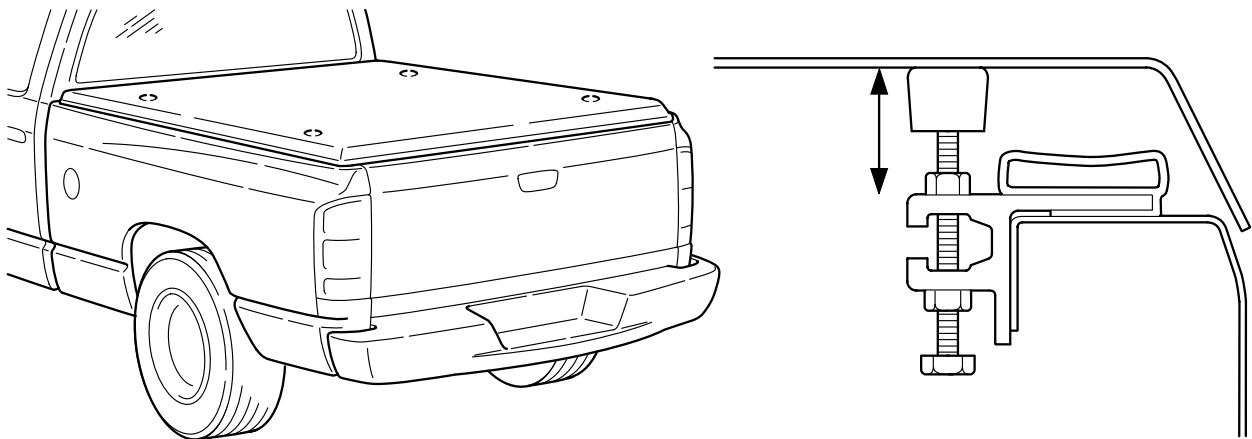

13

All four bumpers must be compressed slightly with lid and tailgate closed.
 Las cuatro defensas deben estar levemente comprimidas con la tapa y la compuerta trasera cerradas.
 Les quatre amortisseurs doivent être légèrement comprimés lorsque le capot et le hayon sont fermés.

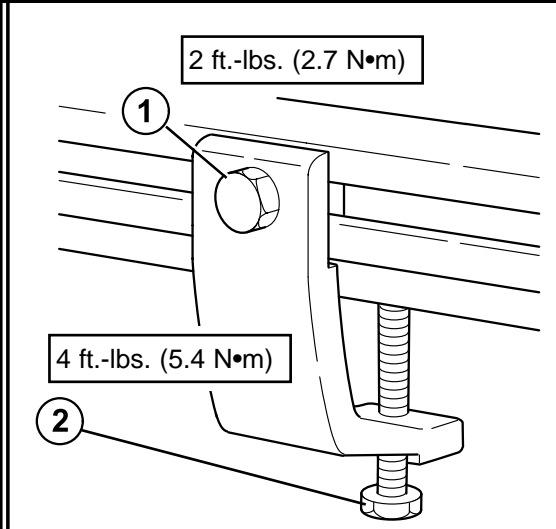

14 6x

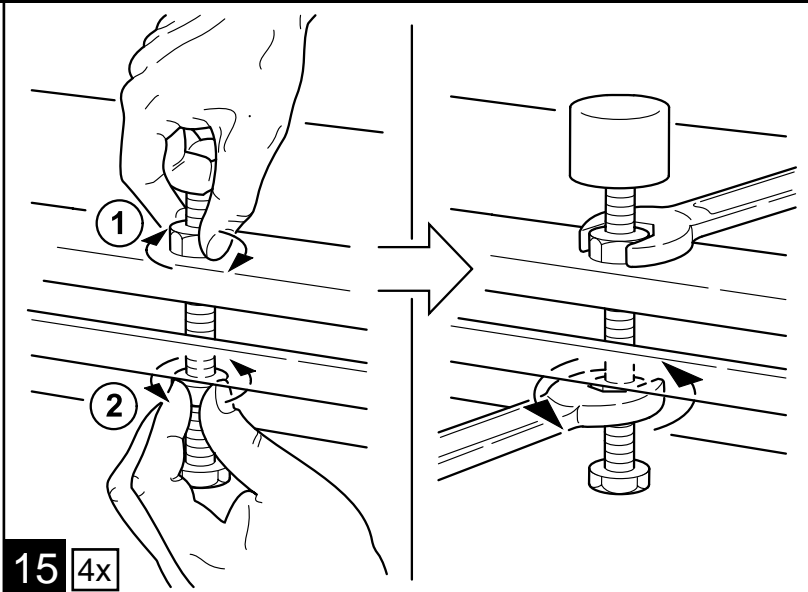

15 4x

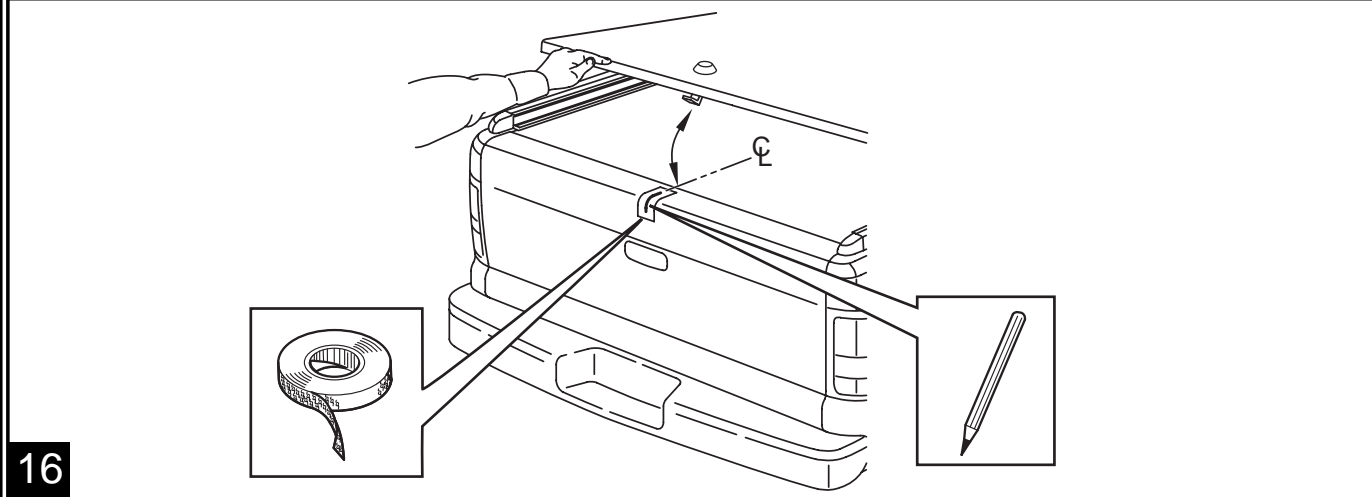

16

If the truck is equipped with a Dodge bedliner, the tailgate cover needs to be modified as shown.

WITH BEDLINER

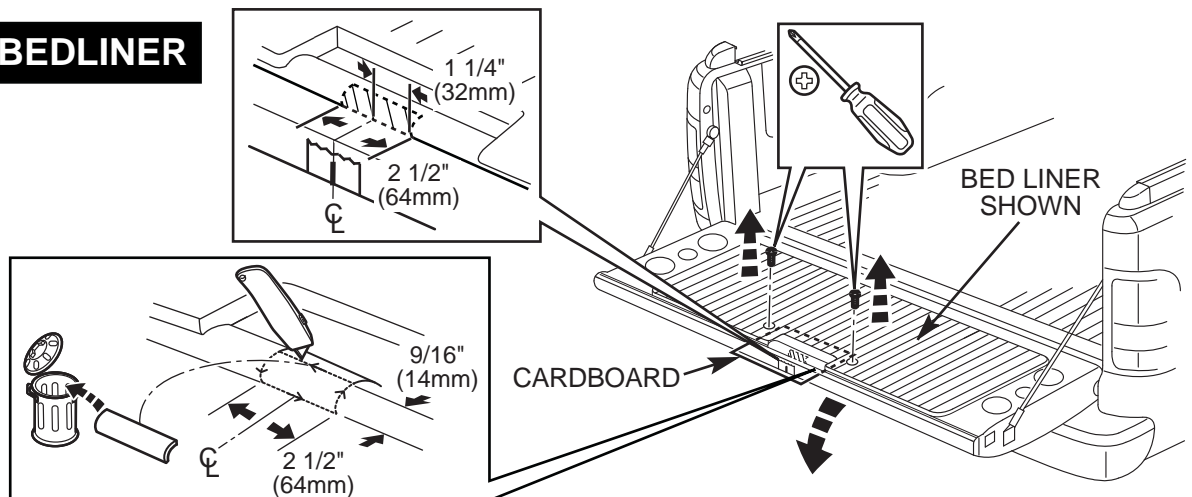

Remove 2 screws in tailgate cover to allow cardboard to be inserted to protect painted surface. **Only** molded bedliner cover needs to be modified (remove 1/2 of the bumped surface). **DO NOT** modify the plastic spoiler cover - the footman loop will attach directly to it. (Refer to step 18A). Remove and discard cardboard.

17

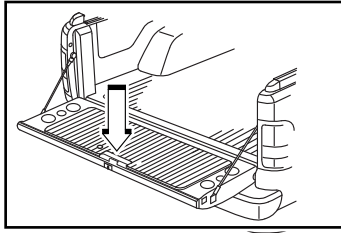

WITH BEDLINER

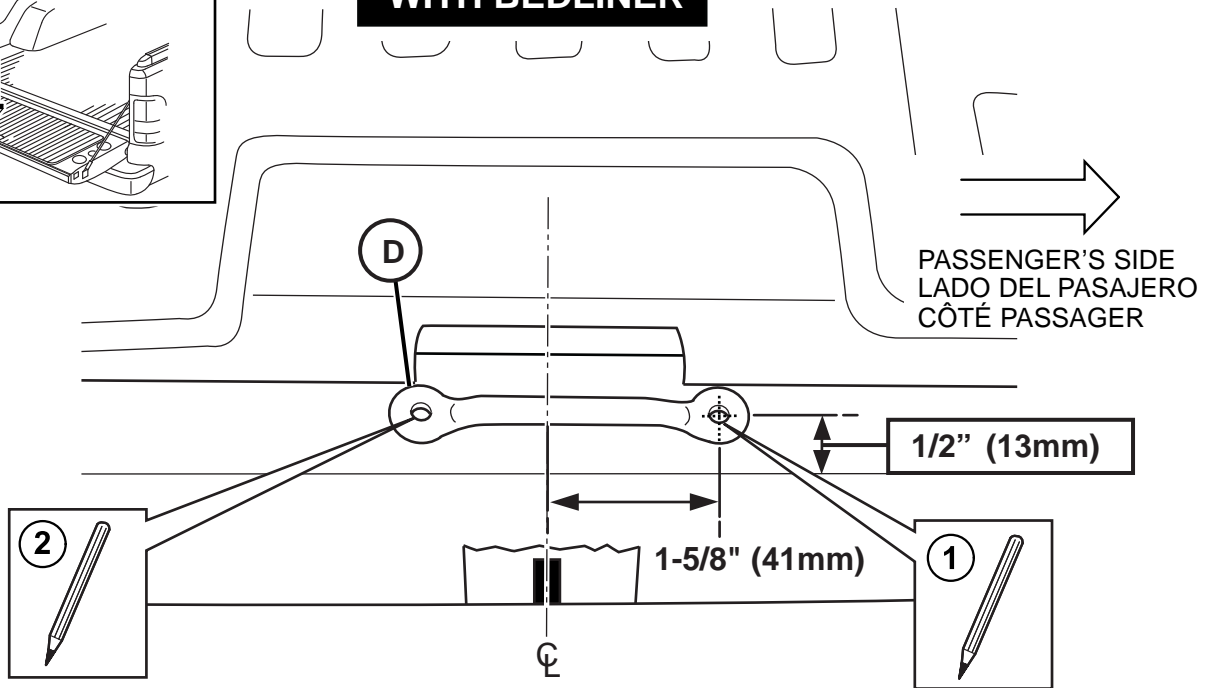

- 1 Using centerline of tailgate, measure 1 5/8" (41mm) to the passenger side.
- 2 Measure down 1/2" (13mm) from top of spoiler.
- 3 Mark that hole location.
- 4 Important, using the footman loop (item D) as a template mark the opposite hole on footman loop (item D) to be drilled.

18A

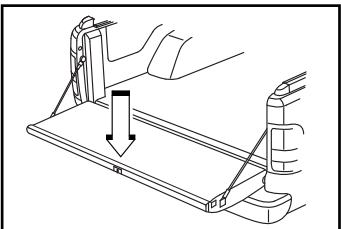

WITHOUT BEDLINER

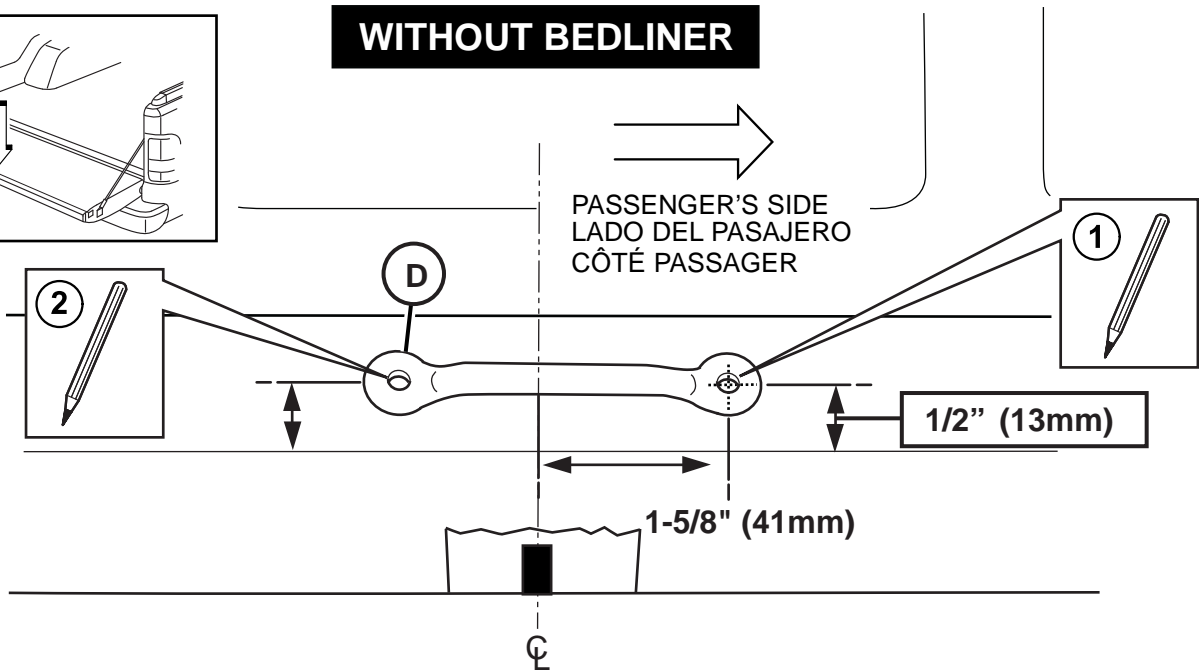

- 1 Using centerline of tailgate, measure 1 5/8" (41mm) to the passenger side.
- 2 Measure down 1/2" (13mm) from top of spoiler
- 3 Mark that hole location.
- 4 Important, using the footman loop (item D) as a template mark the opposite hole on footman loop (item D) to be drilled.

18B

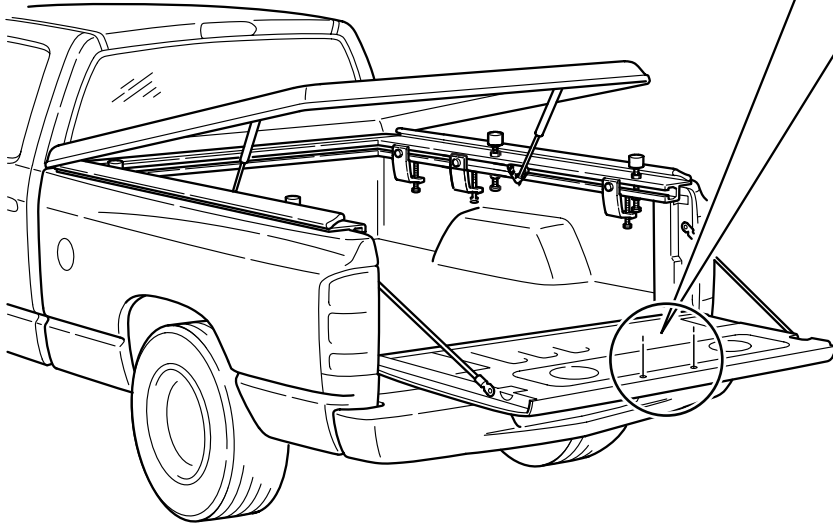
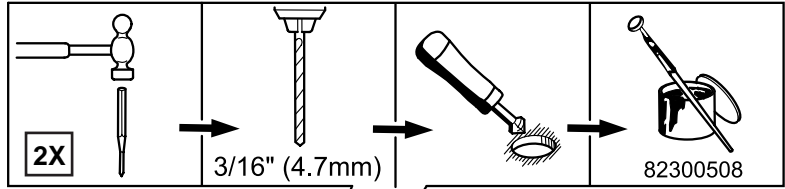

19

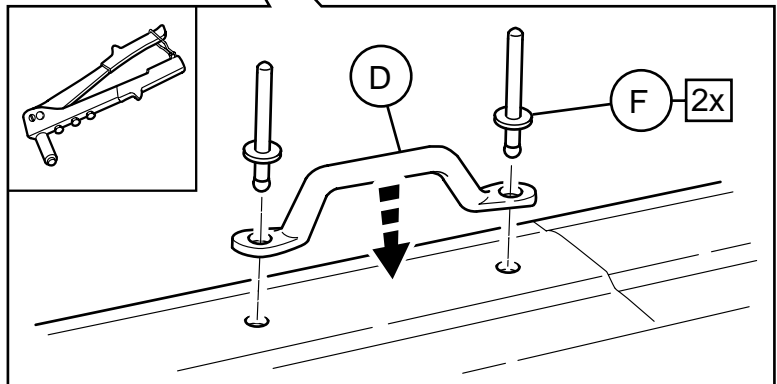
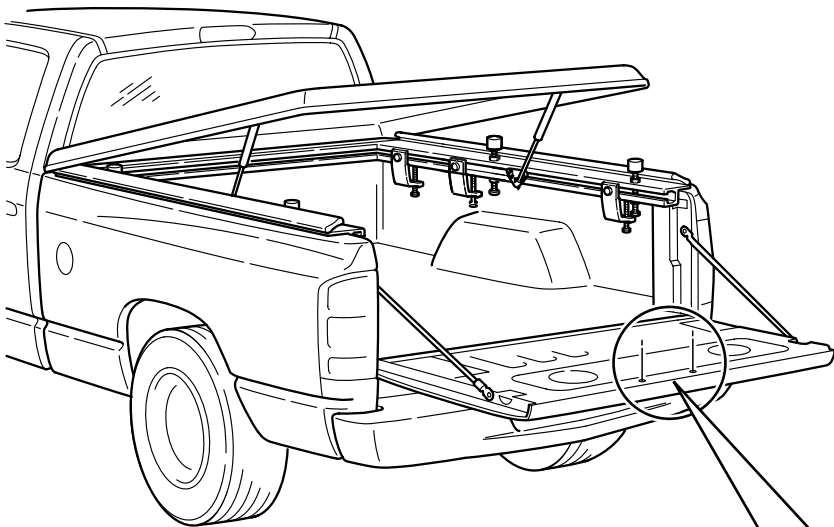

20

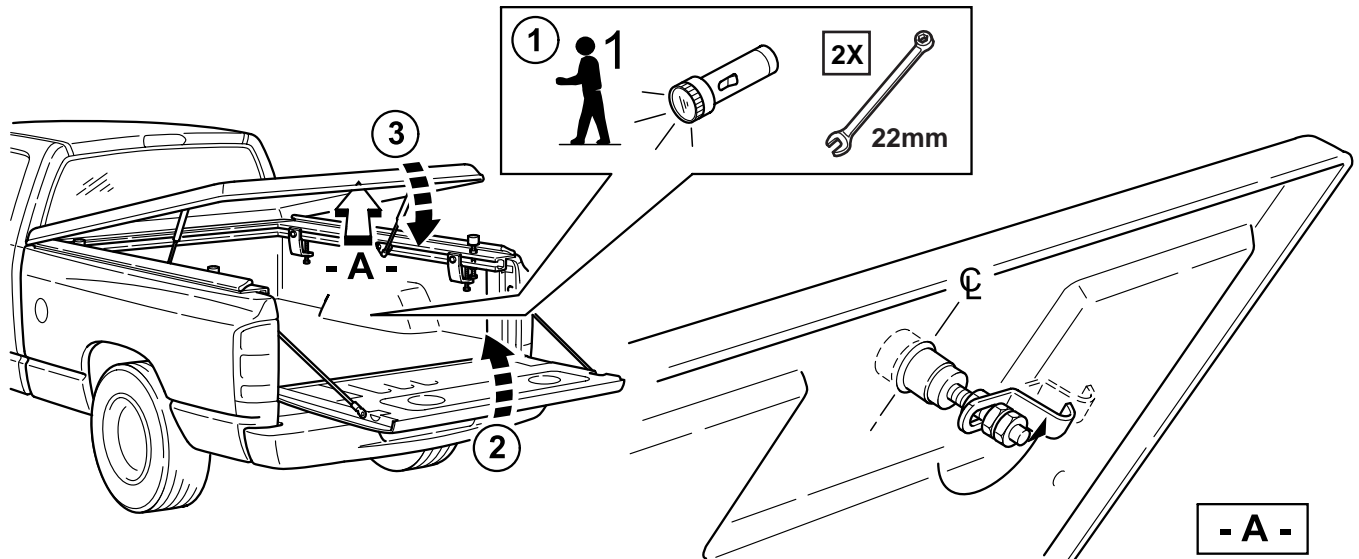
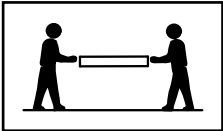

21

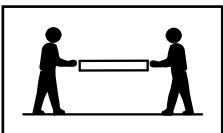

Note: The pawl is adjustable (front to rear) to be located so it engages footman loop (Item D).
If necessary, the tonneau can be adjusted (front and rear) if the pawl can not be adjusted as described.

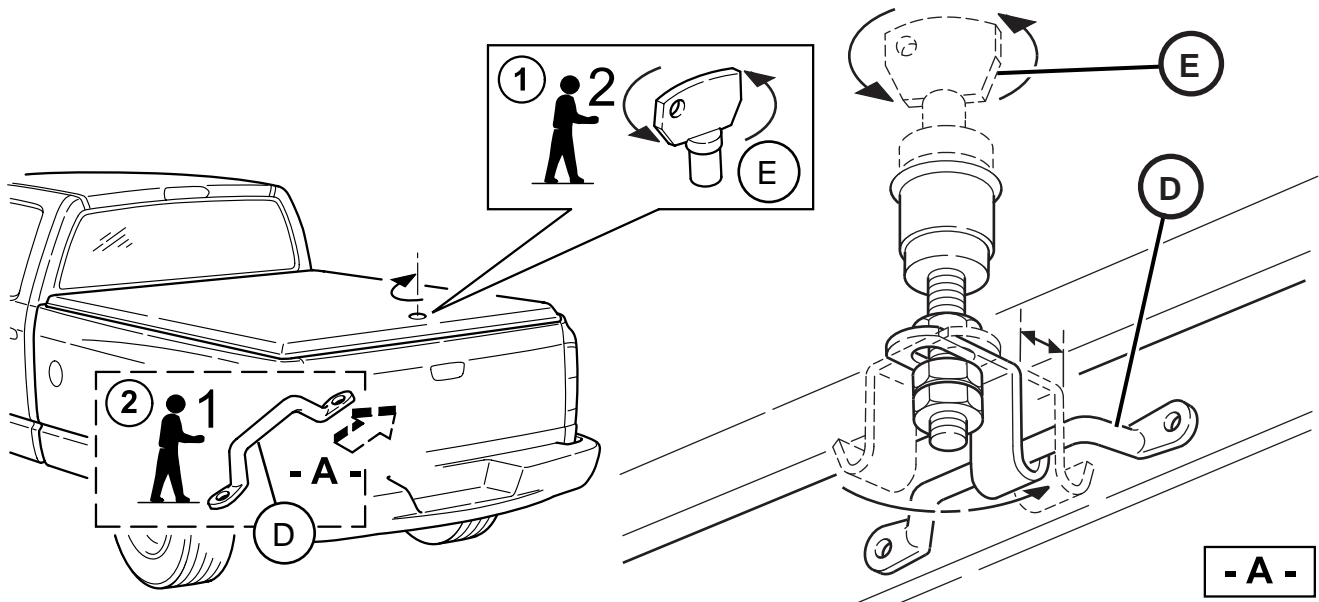

22

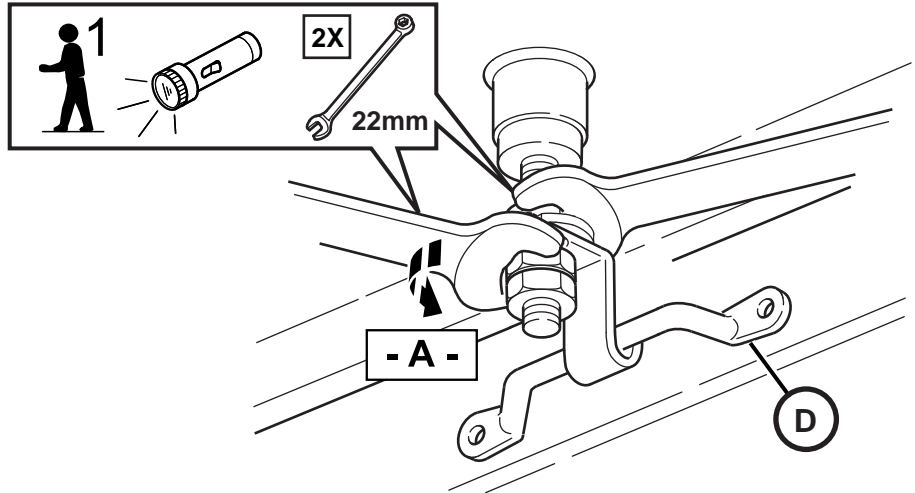
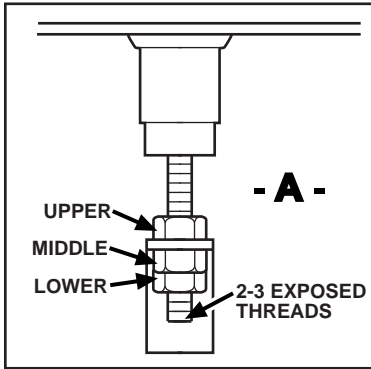

24

WITH WRENCHES SHOWN, HOLD UPPER NUT AND TIGHTEN MIDDLE NUT

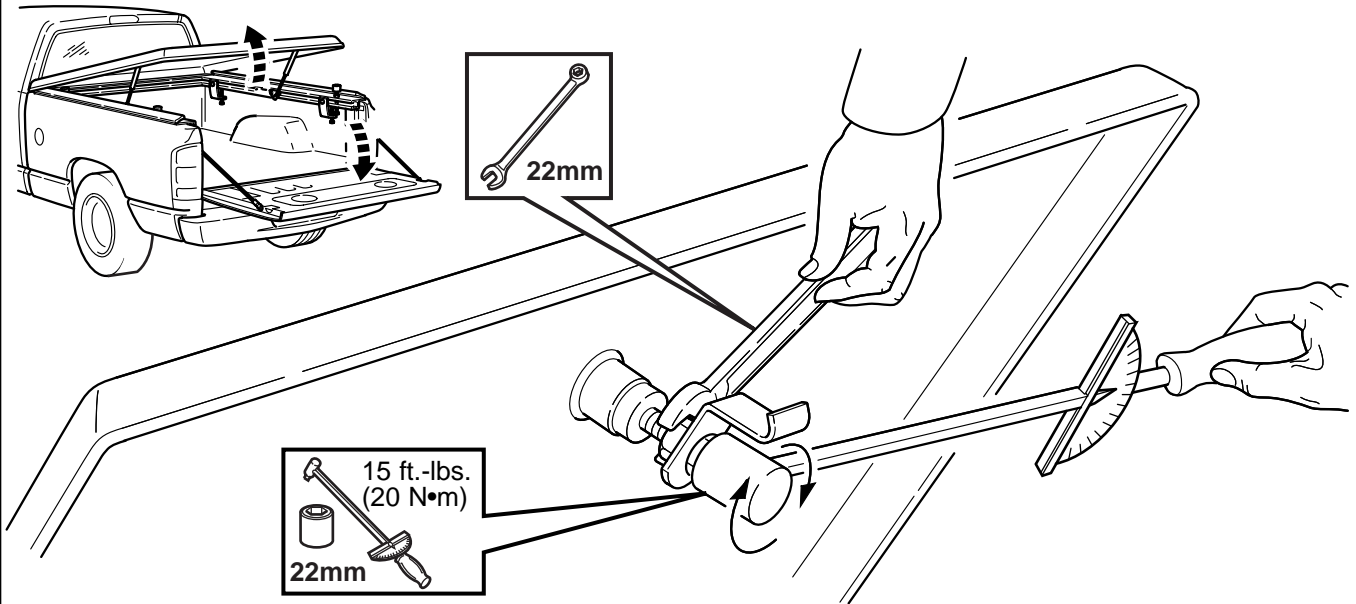

25

WITH WRENCHES SHOWN, HOLD UPPER NUT AND TORQUE THE LOWER NUT

NO TONNEAU IS 100% WATERPROOF - This tonneau has been rigorously tested under various types of car wash systems with minimal water entry.

FOR TECHNICAL ASSISTANCE, SERVICE REPLACEMENT PARTS OR CUSTOMER SERVICE CALL: 1-800-533-0450 X160 OR 1-507-695-2378 X160