

# SALES CODES

The Body Code Plate contains the specific sales codes of components used in the particular vehicle. This information is useful to the technician to identify the vehicle's engine and transmission. By comparing the sales codes for engines and transmissions from the Body Code Plate with the sales codes provided below, you can more accurately identify the correct replacement parts. Refer to the applicable service manual for Body Code Plate location and decoding.

## ENGINE SALES CODES

ENGINE CODE	DESCRIPTION
EBG	2.0L DOHC, Turbo
ECC	2.0L DOHC
ECF	2.0L DOHC
ECG	3.5L SOHC
ED2	2.4L DOHC, PZEV
EDM	2.4L DOHC, Mexico Unique
EDT	2.4L DOHC, Turbo
EDV	2.4L DOHC, Turbo H.O.
EDZ	2.4L DOHC
EEE	2.7L DOHC FFV
EER	2.7L DOHC
EES	2.7L DOHC
EF7	3.0L SOHC
EF8	3.0L DOHC
EF9	3.0L DOHC, Turbo
EGD	3.3L V6
EGG	3.5L SOHC
EGM	3.3L Ethanol Flex Fuel
EGW	3.2L DOHC
EKG	3.7L V6
EJA	1.8L SOHC
EJB	1.5L SOHC
ELM	5.9L MPI
ELN	5.2L CNG
ELP	5.2L LPG
EPE	2.5L MPI
ERH	4.0L MPI
ESF	6.1L V8 Hemi
ETC	5.9L Turbo Diesel
ETH	5.9L Turbo Diesel, H.O.
EVA	4.7L V8
EVC	4.7L V8 H.O.
EWA	8.0L MPI
EWB	8.0L V10
EWC	8.3L V10
EY7	2.4L SOHC
EZA	5.7L V8 Hemi
EZB	5.7L V8 Hemi MDS

## TRANSMISSION SALES CODES

TRANSMISSION CODE	DESCRIPTION
DD4	5-Speed Manual (NVT 350)
DD5	5-Speed Manual (NVT 350)
DDC	5-Speed Manual (NVG 3500)
DDK	5-Speed Manual (NVG 1500)
DDO	5-Speed Manual (AX15)
DDP	5-Speed Manual (NVG 4500)
DDP	5-Speed Auto (NVG 4500)
DDQ	5-Speed Manual (AX15) (AX5)
DEE	6-Speed Manual (NVG 5600)
DG4	4-Speed Auto (45RFE)
DG6	4-Speed Auto (42RLE)
DG8	4-Speed Auto (48RE)
DGA	3-Speed Auto (31TH)
DGB	4-Speed Auto (47RE)
DGD	3-Speed Auto (30RH)
DGG	3-Speed Auto (32RH)
DGJ	5-Speed Auto (WA580)
DGK	4-Speed Auto (42RE)
DGL	4-Speed Electronic Auto Transaxle (41TE)
DGM	3-Speed Auto (31TH)
DGP	4-Speed Auto (47RE)
DGQ	5-Speed Auto (545RFE)
DGS	4-Speed Auto (AW4)
DGT	4-Speed Auto (46RE)
DGW	4-Speed Auto (44RE)
DGX	4-Speed Electronic Auto Transaxle (42LE)

## 2.0L SOHC 4-CYLINDER LONG BLOCK



### PRODUCT FEATURES:

- New Pistons, Pins, and Rings
- New Timing Belt
- New Gaskets and Seals
- New Bearings
- New Freeze Plugs
- Gasket Pack Includes:
  - > OIL PAN GASKET (ONLY 94-95)
  - > VALVE COVER GASKET (ONLY 94-95)
  - > OIL PUMP PICKUP TUBE SEAL (ONLY 94-95)
  - > EXHAUST MANIFOLD GASKET
  - > WATER INLET TUBE O-RING
  - > CRANKSHAFT SPROCKET SCREW
  - > INTAKE MANIFOLD GASKET
  - > SPARK PLUG TUBE SEAL (4) (ONLY 94-95)
  - > CAM SENSOR SEAL
- Remanufactured Crankshaft
- Remanufactured Cylinder Head
- Remanufactured Rocker Arms
- Remanufactured Valves
- Remanufactured Camshaft
- Remanufactured Cylinder Block
- Remanufactured Connecting Rods
- Remanufactured Oil Pump
- Remanufactured Water Pump
- Remanufactured Rocker Shafts

All other components are remanufactured to DaimlerChrysler Engineering specifications or replaced with O.E. parts.

1996-2000 2.0L SOHC  
(1994-1995 2.0L SOHC DOES  
NOT INCLUDE OIL PAN  
AND VALVE COVER)



## 2.0L SOHC CYLINDER HEAD

### PRODUCT FEATURES:

- New Seals and Freeze Plugs
- 100% Vacuum Leak Tested to Ensure Reliable and Dependable Performance
- Gasket Pack Includes:
  - > SPARK PLUG TUBE SEAL (4)
  - > VALVE COVER GASKET
  - > EGR VALVE GASKET
  - > CAMSHAFT SENSOR SEAL
  - > INTAKE MANIFOLD GASKET
  - > CYLINDER HEAD GASKET
- Remanufactured Cylinder Head
- Remanufactured Rocker Arms
- Remanufactured Rocker Shafts
- Remanufactured Intake & Exhaust Valves



## 2.0L SOHC 4-CYLINDER LONG BLOCK MATRIX

### 2.0L SOHC CYLINDER HEAD MATRIX

#### 2.0L SOHC 4-CYLINDER LONG BLOCK MATRIX

MODEL YEAR	ENGINE	CYLINDER BLOCK	CYLINDER HEAD(S)	CRANKSHAFT	MAIN & ROD BEARINGS	CONNECTING ROD SET	PISTON, PIN, RINGS SET	INTERMEDIATE SHAFT	CAMSHAFT(S)	BALANCE SHAFT SYSTEM	VALVES AND SPRINGS	ROCKER ARMS	ROCKER SHAFTS	PUSH RODS	TAPPETS	LASH ADJUSTERS	SPARK PLUG TUBES	TIMING BELT SYSTEM	TIMING CHAIN SYSTEM	CYL. HEAD GASKET(S)	V. COVER(S) W/GASKETS	OIL PUMP	OIL PICKUP	OIL PAN	FRONT TIMING COVER	TIMING INNER COVER	ALTERNATOR BRACKET	WATER PUMP	INSTALLER'S GASKET SET	RETURNABLE CONTAINER	CARDBOARD BOX	WOODEN BOX
2005-03	2.0L SOHC	X	X	X	X	X	X		X		X	X	X		X	X	X	X		X		X	X									
2002-96	2.0L SOHC	X	X	X	X	X	X		X		X	X	X		X	X	X	X		X		X	X									
1995-94	2.0L SOHC	X	X	X	X	X	X		X		X	X	X		X	X	X	X		X		X	X									

#### 2.0L SOHC CYLINDER HEAD MATRIX

MODEL YEAR (excludes mmc versions)	ENGINE	CYLINDER HEAD	CAMSHAFT(S)	VALVES AND SPRINGS	ROCKER ARMS	ROCKER SHAFTS	TAPPETS	LASH ADJUSTERS	SPARK PLUG TUBES	CYL. HEAD GASKET	INSTALLER'S GASKET SET	CARDBOARD BOX
2005-95	2.0L SOHC	X	X	X	X	X	X	X	X	X	X	X

# 2.0L/2.4L 4-CYLINDER DOHC LONG BLOCK



## PRODUCT FEATURES:

- New Pistons, Pins & Rings
- New Rockers & Lash Adjusters
- New Bearings
- New Timing Belt & Tensioner\*
- New Gaskets & Seals
- 2.0L Gasket Pack Includes:
  - > VALVE COVER GASKET
  - > EXHAUST MANIFOLD GASKET
  - > INTAKE MANIFOLD GASKET
  - > THERMOSTAT HOUSING GASKET (FRONT EXHAUST ONLY)
  - > CAM SENSOR SEAL
  - > SEMICIRCULAR REAR CAM SEAL
  - > SPARK PLUG WELL SEAL
  - > OIL PUMP PICKUP TUBE O-RING
- 2.4L Gasket Pack Includes:
  - > VALVE COVER GASKET
  - > EXHAUST MANIFOLD GASKET
  - > INTAKE MANIFOLD GASKET
  - > THERMOSTAT HOUSING GASKET (FRONT EXHAUST ONLY)
  - > CAM SENSOR SEAL
  - > SEMICIRCULAR REAR CAM SEAL
  - > SPARK PLUG WELL SEAL
  - > OIL PAN GASKET (UNIVERSAL W/BAFFLE)
  - > OIL PUMP PICKUP TUBE O-RING

- Remanufactured Camshaft
- Remanufactured Cylinder Block
- Remanufactured Cylinder Head
- Remanufactured Crankshaft & Connecting Rods
- Remanufactured Oil Pump
- Remanufactured Water Pump
- Remanufactured Balance Shaft Unit (2.4L only)
- Remanufactured Valves & Springs

**2.4L DOHC SHOWN. INCLUDES  
BALANCE SHAFT UNIT.  
(2.0L/2.4L DOHC ENGINES DO  
NOT INCLUDE VALVE COVER  
OR OIL PAN.)**

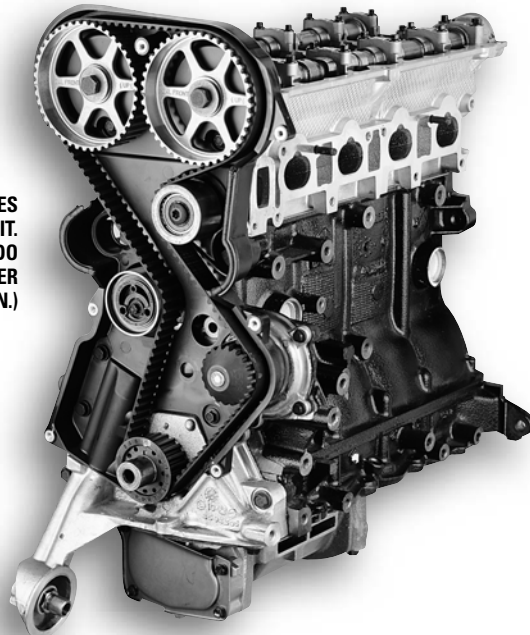

All other components are remanufactured to DaimlerChrysler Engineering specifications or replaced with O.E. parts.

\*Due to design changes, Mopar Reman Engines may include NEW Outer Timing Covers where required.

# 2.0L/2.4L DOHC CYLINDER HEAD

## PRODUCT FEATURES:

- Remanufactured Valves and Springs
- New Seals and Freeze Plugs
- 100% Vacuum Leak Tested to Ensure Reliable and Dependable Performance
- Gasket Pack Includes:
  - > VALVE COVER GASKET
  - > SPARK PLUG WELL SEALS
  - > INTAKE MANIFOLD GASKET
  - > CYLINDER HEAD GASKET
  - > CAMSHAFT SENSOR SEAL



## 2.0L/2.4L 4-CYLINDER DOHC LONG BLOCK MATRIX

### 2.0L/2.4L DOHC CYLINDER HEAD MATRIX

#### 2.0L/2.4L 4-CYLINDER DOHC LONG BLOCK MATRIX

MODEL YEAR	ENGINE	CYLINDER BLOCK	CYLINDER HEAD(S)	CRANKSHAFT	MAIN & ROD BEARINGS	CONNECTING ROD SET	PISTON, PIN, RINGS SET	INTERMEDIATE SHAFT	CAMSHAFT(S)	BALANCE SHAFT SYSTEM	VALVES AND SPRINGS	ROCKER ARMS	ROCKER SHAFTS	PUSH RODS	TAPPETS	LASH ADJUSTERS	SPARK PLUG TUBES	TIMING BELT SYSTEM	TIMING CHAIN SYSTEM	CYL. HEAD GASKET(S)	V. COVER(S) W/GASKETS	OIL PUMP	OIL PICKUP	OIL PAN	FRONT TIMING COVER	TIMING INNER COVER	ALTERNATOR BRACKET	WATER PUMP	INSTALLER'S GASKET SET	RETURNABLE CONTAINER	CARDBOARD BOX	WOODEN BOX
1999-95	2.0L DOHC RE	X	X	X	X	X	X		X	X	X	X				X		X		X		X				X		X	X	X		
1999-94	2.0L DOHC FE	X	X	X	X	X	X		X		X	X				X		X		X		X				X		X	X	X		
2002-01	2.4L DOHC RE	X	X	X	X	X	X		X	X	X	X				X		X		X		X				X		X	X	X		
2000-95	2.4L DOHC RE	X	X	X	X	X	X		X	X	X	X				X		X		X		X				X		X	X	X		

#### 2.0L/2.4L DOHC CYLINDER HEAD MATRIX

MODEL YEAR	ENGINE	CYLINDER HEAD	CAMSHAFT(S)	VALVES AND SPRINGS	ROCKER ARMS	ROCKER SHAFTS	TAPPETS	LASH ADJUSTERS	SPARK PLUG TUBES	CYL. HEAD GASKET	INSTALLER'S GASKET SET	CARDBOARD BOX
1999-95	2.0L DOHC RE	X		X						X	X	X
1999-95	2.0L DOHC FE	X		X						X	X	X
2002-95 (excludes mmc versions)	2.4L DOHC RE	X		X						X	X	X

## 2.2L/2.5L 4-CYLINDER LONG BLOCK



### PRODUCT FEATURES:

- New Pistons, Pins and Rings
  - New Timing Belt and Tensioner
  - New Main, Connecting Rod and Cam Bearings
  - New Lifters
  - New Freeze Plugs
  - New Gaskets and Seals
  - New Rockers
  - Oil Pump Rotors
  - 2.2L Gasket Pack Includes:
    - > VALVE COVER GASKET
    - > MANIFOLD GASKET
    - > WATER PUMP O-RING
    - > THERMOSTAT GASKET
    - > OIL PAN SEAL KIT (EXCLUDING ENGINES W/BALANCE SHAFT UNIT)
  - 2.5L Long Block (w/Oil Pan) Gasket Pack Includes:
    - > VALVE COVER GASKET
    - > MANIFOLD GASKET
    - > WATER PUMP O-RING
    - > THERMOSTAT GASKET
- Remanufactured Crankshaft
  - Remanufactured Cylinder Head
  - Remanufactured Valves
  - Remanufactured Block
  - Remanufactured Connecting Rods
  - Remanufactured Oil Pump
  - Remanufactured Camshaft
  - Remanufactured Balance Shaft Unit (2.5L only)

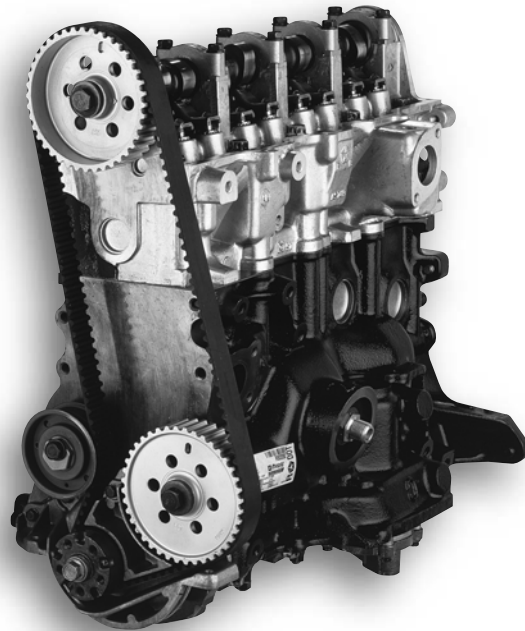

All other components are remanufactured to DaimlerChrysler Engineering specifications or replaced with O.E. parts.

## 2.2L/2.5L 4-CYLINDER CYLINDER HEAD

### PRODUCT FEATURES:

- Rockers and Lash Adjusters
  - Springs
  - Spark Plug Tubes
  - New Seals and Freeze Plugs
  - 100% Vacuum Leak Tested to Ensure Reliable and Dependable Performance
  - Gasket Pack Includes:
    - > VALVE COVER GASKET
    - > CYLINDER HEAD GASKET
    - > WATER OUTLET GASKET
    - > MANIFOLD GASKET
- Remanufactured Cylinder Head
  - Remanufactured Rocker Arms
  - Remanufactured Camshaft
  - Remanufactured Intake and Exhaust Valves

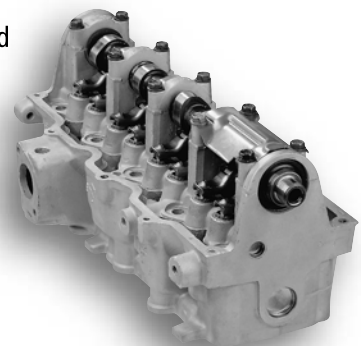

## 2.2L/2.5L 4-CYLINDER LONG BLOCK MATRIX

## 2.2L/2.5L 4-CYLINDER CYLINDER HEAD MATRIX

### 2.2L/2.5L 4-CYLINDER LONG BLOCK MATRIX

MODEL YEAR	ENGINE	CYLINDER BLOCK	CYLINDER HEAD(S)	CRANKSHAFT	MAIN & ROD BEARINGS	CONNECTING ROD SET	PISTON, PIN, RINGS SET	INTERMEDIATE SHAFT	CAMSHAFT(S)	BALANCE SHAFT SYSTEM	VALVES AND SPRINGS	ROCKER ARMS	ROCKER SHAFTS	PUSH RODS	TAPPETS	LASH ADJUSTERS	SPARK PLUG TUBES	TIMING BELT SYSTEM	TIMING CHAIN SYSTEM	CYL. HEAD GASKET(S)	V. COVER(S) W/GASKETS	OIL PUMP	OIL PICKUP	OIL PAN	FRONT TIMING COVER	TIMING INNER COVER	ALTERNATOR BRACKET	WATER PUMP	INSTALLER'S GASKET SET	RETURNABLE CONTAINER	CARDBOARD BOX	WOODEN BOX
1995-81	2.2L Carb & EFI	X	X	X	X	X	X	X	X		X	X				X		X		X		X	X								X	X
1990-89	2.2L Turbo IV	X	X	X	X	X	X	X	X	X	X	X				X		X		X		X	X								X	X
1990-84	2.2L Turbo I / II	X	X	X	X	X	X	X	X		X	X				X		X		X		X	X								X	X
1995-86	2.5L EFI & Turbo	X	X	X	X	X	X	X	X		X	X				X		X		X		X	X								X	X

### 2.2L/2.5L 4-CYLINDER CYLINDER HEAD MATRIX

MODEL YEAR	ENGINE	CYLINDER HEAD	CAMSHAFT(S)	VALVES AND SPRINGS	ROCKER ARMS	ROCKER SHAFTS	TAPPETS	LASH ADJUSTERS	SPARK PLUG TUBES	CYL. HEAD GASKET	INSTALLER'S GASKET SET	CARDBOARD BOX
1995-81	2.2L /2.5L All	X	X	X	X			X		X	X	X



## 2.5L SOHC 24-VALVE V6 LONG BLOCK



### PRODUCT FEATURES:

- New Bearings
- New Tappets
- New Gaskets
- New Water Pump
- New Oil Seals
- New Timing Belt
- New Pistons and Pins
- New Piston Rings
- New Freeze Plugs
- Gasket Pack Includes:
  - > EGR VALVE GASKET
  - > DIPSTICK TUBE O-RINGS
  - > COOLANT TUBE O-RING
  - > ENGINE FRONT CASE O-RINGS
  - > OIL STRAINER GASKET
  - > OIL PICKUP TUBE
  - > CYLINDER HEAD SPARK PLUG GUIDE SEALS
  - > CYLINDER HEAD ROCKER COVER GASKETS
  - > INTAKE MANIFOLD GASKET
  - > OIL FILLER CAP GASKET
  - > OIL FILTER GAUGE O-RING
  - > THERMOSTAT CASE GASKETS
  - > CYLINDER HEAD O-RING
  - > EXHAUST MANIFOLD GASKET
  - > OIL FILTER BRACKET GASKET
  - > PLUG EGR VALVE
- Remanufactured Cylinder Block
- Remanufactured Cylinder Heads
- Remanufactured Crankshaft
- Remanufactured Camshafts
- Remanufactured Oil Pump
- Remanufactured Connecting Rods
- Remanufactured Rocker Arms
- Remanufactured Rocker Shafts
- Remanufactured Valves

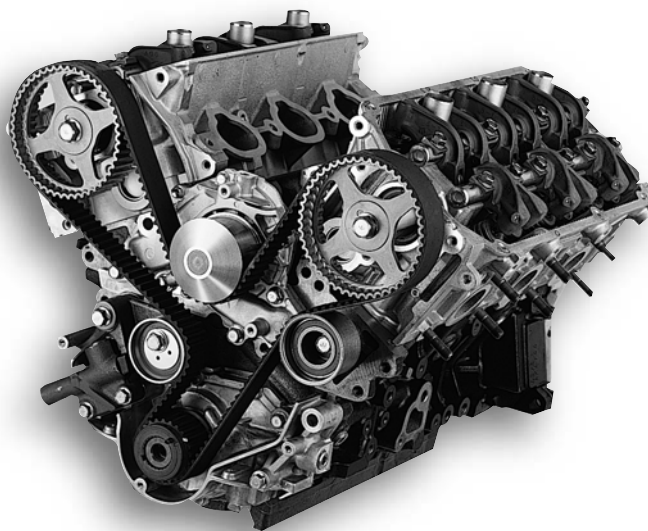

All other components are remanufactured to DaimlerChrysler Engineering specifications or replaced with O.E. parts.

## 2.5L SOHC CYLINDER HEAD

### PRODUCT FEATURES:

- New Lash Adjusters
- Spark Plug Tubes
- New Seals and Freeze Plugs
- 100% Vacuum Leak Tested to Ensure Reliable and Dependable Performance
- Gasket Pack Includes:
  - > CYLINDER HEAD GASKET ONLY
  - > PLUG EGR VALVE
- Remanufactured Cylinder Head
- Remanufactured Camshaft
- Remanufactured Rocker Arms
- Remanufactured Rocker Shafts
- Remanufactured Intake and Exhaust Valves

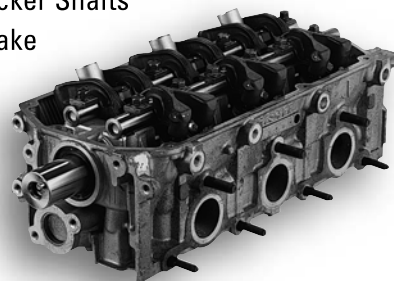



## 2.5L SOHC 24-VALVE V6 LONG BLOCK MATRIX

### 2.5L SOHC CYLINDER HEAD MATRIX

MODEL YEAR	ENGINE	
2000-95	2.5L MMC	
x		CYLINDER HEAD
x		CAMSHAFT(S)
x		VALVES AND SPRINGS
x		ROCKER ARMS
x		ROCKER SHAFTS
x		TAPPETS
x		LASH ADJUSTERS
x		SPARK PLUG TUBES
x		CYL. HEAD GASKET
x		INSTALLER'S GASKET SET
x		CARDBOARD BOX

### 2.5L SOHC CYLINDER HEAD MATRIX

MODEL YEAR	ENGINE	
2000-95	2.5L MMC	
x		CYLINDER BLOCK
x		CYLINDER HEAD(S)
x		CRANKSHAFT
x		MAIN & ROD BEARINGS
x		CONNECTING ROD SET
x		PISTON, PIN, RINGS SET
		INTERMEDIATE SHAFT
x		CAMSHAFT(S)
		BALANCE SHAFT SYSTEM
x		VALVES AND SPRINGS
x		ROCKER ARMS
x		ROCKER SHAFTS
		PUSH RODS
x		TAPPETS
x		LASH ADJUSTERS
x		SPARK PLUG TUBES
x		TIMING BELT SYSTEM
		TIMING CHAIN SYSTEM
x		CYL. HEAD GASKET(S)
		V. COVER(S) W/GASKETS
x		OIL PUMP
x		OIL PICKUP
		OIL PAN
		FRONT TIMING COVER
		TIMING INNER COVER
x		ALTERNATOR BRACKET
x		WATER PUMP
x		INSTALLER'S GASKET SET
		RETURNABLE CONTAINER
		CARDBOARD BOX
x		WOODEN BOX

### 2.5L SOHC 24-VALVE V6 LONG BLOCK MATRIX

## 2.5L 4-CYLINDER LONG BLOCK



### PRODUCT FEATURES:

- New Pistons, Pins and Rings
- New Timing Chain and Gears
- New Main, Connecting Rod and Cam Bearings
- New Gaskets and Seals
- New Push Rods
- New Oil Pump and Pickup Screen
- New Camshaft and Lifters
- New Valves
- New Valve Springs
- New Freeze Plugs
- Gasket Pack Includes:
  - > WATER PUMP GASKET
  - > THERMOSTAT GASKET
  - > DISTRIBUTOR GASKET
  - > THROTTLE BODY GASKET
  - > INTAKE AND EXHAUST GASKET
- Remanufactured Crankshaft
- Remanufactured Cylinder Head
- Remanufactured Cylinder Block
- Remanufactured Connecting Rods

All other components are remanufactured to DaimlerChrysler Engineering specifications or replaced with O.E. parts.

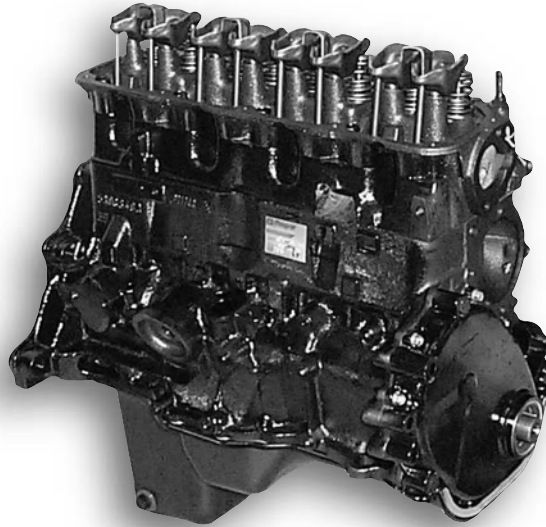

## 2.5L CYLINDER HEAD

### PRODUCT FEATURES:

- New Intake and Exhaust Valves
- New Valve Springs
- New Freeze Plugs
- New Seals
- 100% Vacuum Leak Tested to Ensure Reliable and Dependable Performance
- Cylinder Head Gasket – Order Separately

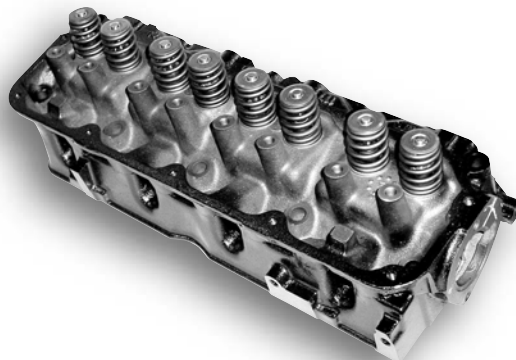



## 2.7L 6-CYLINDER LONG BLOCK



### PRODUCT FEATURES:

- New Pistons, Pins and Rings
- New Timing Chains and Guides
- New Main and Connecting Rod Bearings
- New Freeze Plugs
- New Gaskets and Seals
- Gasket Pack Includes:
  - > VALVE COVER GASKETS
  - > WATER OUTLET GASKET
  - > PLENUM INTAKE MANIFOLD GASKET
  - > INTAKE MANIFOLD GASKETS
  - > FUEL RAIL GASKET
- Remanufactured Cylinder Block
- Remanufactured Crankshaft
- Remanufactured Cylinder Heads
- Remanufactured Valves and Springs
- Remanufactured Camshafts (4)
- Remanufactured Rocker Arms (24)
- Remanufactured Rocker Shafts and Pedestals
- Remanufactured Oil Pump
- Remanufactured Water Pump
- Remanufactured Connecting Rods

All other components are remanufactured to DaimlerChrysler Engineering specifications or replaced with O.E. parts.



## 2.7L CYLINDER HEAD

### PRODUCT FEATURES:

- Remanufactured Cylinder Head
- Valves and Springs
- 100% Vacuum Leak Tested to Ensure Reliable and Dependable Performance
- Gasket Pack Includes:
  - > INTAKE MANIFOLD GASKET
  - > VALVE COVER GASKET
  - > CYLINDER HEAD GASKET

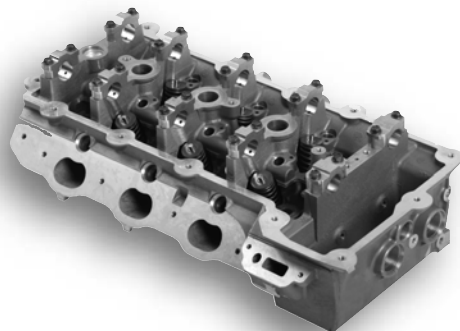

## 2.7L 6-CYLINDER LONG BLOCK MATRIX

### 2.7L CYLINDER HEAD MATRIX

MODEL YEAR	ENGINE																									
2004-98	2.7L DOHC LH																									
		X																								
			X																							
				X																						

### 2.7L CYLINDER HEAD MATRIX

MODEL YEAR	ENGINE																																																							
2004-98	2.7L DOHC LH																																																							
		X																																																						
			X																																																					
				X																																																				
					X																																																			
						X																																																		
							X																																																	
								X																																																
									X																																															
										X																																														
											X																																													
												X																																												
													X																																											
														X																																										
															X																																									
																X																																								
																	X																																							
																		X																																						
																			X																																					
																				X																																				
																					X																																			
																						X																																		
																							X																																	
																								X																																
																									X																															
																										X																														
																											X																													
																												X																												
																													X																											
																														X																										
																															X																									
																																X																								
																																		X																						

### 2.7L 6-CYLINDER LONG BLOCK MATRIX

## 2.7L DIESEL COMPLETE ENGINE



### PRODUCT FEATURES:

- New Pistons, Pins and Rings
- New Timing Chain and Guides
- New Main, Connecting Rod and Cam Bearings
- New Gaskets and Seals
- New Oil Pump and Pickup Tube
- New Oil Cooler
- New Glow Plugs
- New Hoses
- New Fuel Line
- New Filters
- New Wiring Harness
- New Vibration Damper
- New Vacuum Pump
- New Fuel Injectors
- New Fuel Pump
- New High Pressure Pump
- Remanufactured Cylinder Block
- Remanufactured Crankshaft
- Remanufactured Connecting Rods
- Remanufactured Cylinder Heads
- Remanufactured Intake/Exhaust Valves
- Remanufactured Camshafts
- Remanufactured Intake Manifold
- Remanufactured Exhaust Manifold
- Remanufactured Flywheel
- Remanufactured Turbocharger
- Remanufactured Rocker Arms
- Remanufactured Water Pump
- Remanufactured Motor Mounts

### WARRANTY

- One Year, 100,000 Miles

All other components are remanufactured to DaimlerChrysler Engineering specifications or replaced with O.E. parts.

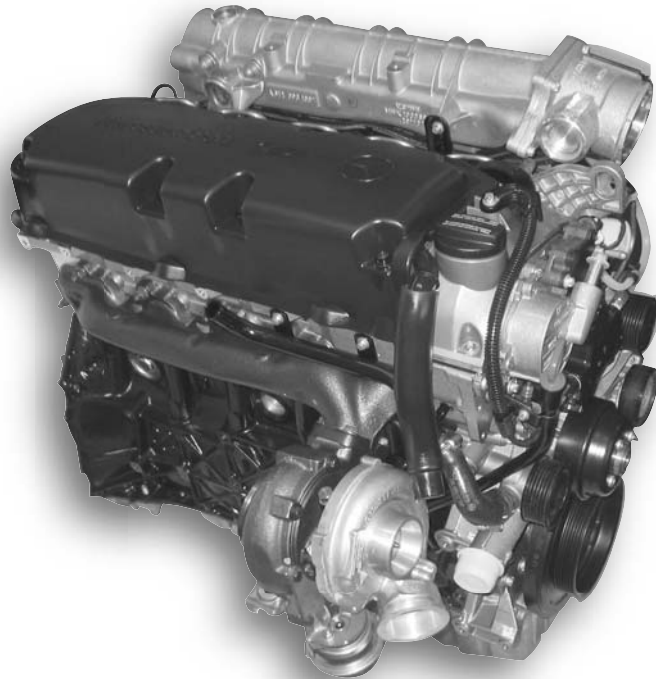

## 2.7L DIESEL COMPLETE ENGINE MATRIX

MODEL YEAR	ENGINE	
2003-01	2.7L Diesel	
x		CYLINDER BLOCK
x		CYLINDER HEAD(S)
x		CRANKSHAFT
x		MAIN & ROD BEARINGS
x		CONNECTING ROD SET
x		PISTON, PIN, RINGS SET
		INTERMEDIATE SHAFT
x		CAMSHAFT(S)
		BALANCE SHAFT SYSTEM
x		VALVES AND SPRINGS
x		ROCKER ARMS
		ROCKER SHAFTS
		PUSH RODS
		TAPPETS
		LASH ADJUSTERS
		SPARK PLUG TUBES
		TIMING BELT SYSTEM
x		TIMING CHAIN SYSTEM
x		CYL. HEAD GASKET(S)
		V. COVER(S) W/GASKETS
x		OIL PUMP
x		OIL PICKUP
		OIL PAN
x		FRONT TIMING COVER
x		TIMING INNER COVER
		ALTERNATOR BRACKET
x		WATER PUMP
x		INSTALLER'S GASKET SET
		RETURNABLE CONTAINER
		CARDBOARD BOX
		WOODEN BOX

### 2.7L DIESEL COMPLETE ENGINE MATRIX



# 3.0L V6 LONG BLOCK



## PRODUCT FEATURES:

- New Pistons, Pins and Rings
- New Timing Belt
- New Main and Connecting Rod Bearings
- New Water Pump
- New Gaskets and Seals
- New Freeze Plugs
- Gasket Pack Includes:
  - > HEATER PIPE GASKET
  - > OIL PAN PLUG GASKET
  - > ROCKER BOLT SEAL OIL
  - > WATER PIPE O-RING
  - > OIL DRAIN PLUG WASHER
  - > DIPSTICK TUBE O-RING
  - > OIL PICKUP SCREEN TUBE
  - > VALVE COVER GASKET
  - > EGR PIPE GASKET
  - > SURGE TANK GASKET
  - > OIL FILTER BRACKET GASKET
  - > EXHAUST MANIFOLD GASKET (2)
  - > EXHAUST CROSSOVER GASKET
  - > INTAKE MANIFOLD GASKET (2)
  - > OIL SCREEN GASKET

- Remanufactured Camshafts
- Remanufactured Crankshaft
- Remanufactured Cylinder Block
- Remanufactured Cylinder Heads
- Remanufactured Connecting Rods
- Remanufactured Oil Pump
- Remanufactured Rocker Arms and Shafts
- Remanufactured Valves and Springs

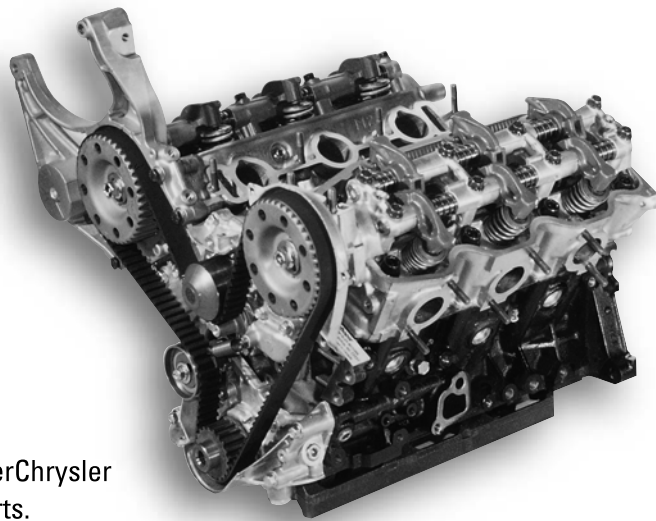

All other components are remanufactured to DaimlerChrysler Engineering specifications or replaced with O.E. parts.

# 3.0L CYLINDER HEAD

## PRODUCT FEATURES:

- Remanufactured Cylinder Head
- Remanufactured Valves and Springs
- 100% Vacuum Leak Tested to Ensure Reliable and Dependable Performance
- Gasket Pack Includes:
  - > OIL-ROCKER BOLT COVER SEAL (2)
  - > DISTRIBUTOR ADAPTER O-RING
  - > SURGE TANK
  - > CAMSHAFT OIL SEAL
  - > EXHAUST CROSSOVER GASKET
  - > INTAKE MANIFOLD GASKET
  - > CYLINDER HEAD CAMSHAFT END SEAL
  - > VALVE COVER GASKET
  - > CYLINDER HEAD GASKET
  - > VALVE COVER BOLT (2)
  - > EXHAUST MANIFOLD GASKET



## 3.0L V6 LONG BLOCK MATRIX

### 3.0L CYLINDER HEAD MATRIX

MODEL YEAR	ENGINE	
2000-87	3.0L MM/C	
		X
		X
		X
		X
		X

### 3.0L CYLINDER HEAD MATRIX

MODEL YEAR	ENGINE	
2000-87	3.0L MM/C	
		X
		X
		X
		X
		X
		X
		X
		X
		X
		X
		X
		X
		X
		X
		X
		X
		X
		X
		X
		X
		X
		X

### 3.0L V6 LONG BLOCK MATRIX

## 3.2L/3.5L ALUMINUM SOHC V6 LONG BLOCK



### PRODUCT FEATURES:

- New Pistons, Pins and Rings
- New Timing Belt and Tensioner
- New Main and Connecting Rod Bearings
- New Freeze Plugs
- New Gaskets and Seals
- New Water Pump
- Gasket Pack Includes:
  - > WATER OUTLET GASKET
  - > VALVE COVER GASKET
  - > PLENUM INTAKE MANIFOLD GASKET
  - > INTAKE MANIFOLD GASKET
  - > FUEL RAIL GASKET
  - > CRANKSHAFT SPROCKET SCREW
  - > CRANKSHAFT SPROCKET WASHER
- Remanufactured Cylinder Block
- Remanufactured Cylinder Heads
- Remanufactured Crankshaft
- Remanufactured Oil Pump
- Remanufactured Camshafts
- Remanufactured Rocker Arms
- Remanufactured Rocker Shafts and Pedestals
- Remanufactured Oil Pan and Pickup Tube
- Remanufactured Timing Belt Covers
- Remanufactured Valves and Springs

All other components are remanufactured to DaimlerChrysler Engineering specifications or replaced with O.E. parts.

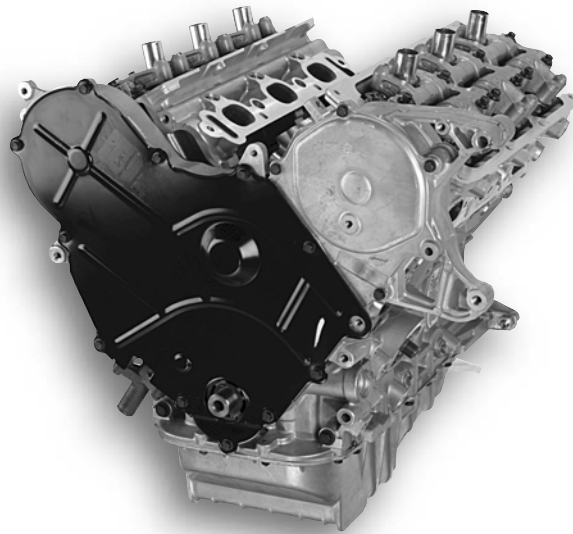

## 3.2L/3.5L ALUMINUM SOHC CYLINDER HEAD

### PRODUCT FEATURES:

- Remanufactured Cylinder Head
- Remanufactured Valves and Springs
- 100% Vacuum Leak Tested to Ensure Reliable and Dependable Performance
- Gasket Pack Includes:
  - > INTAKE MANIFOLD GASKET
  - > VALVE COVER GASKET
- Cylinder Head Gasket – Order Separately

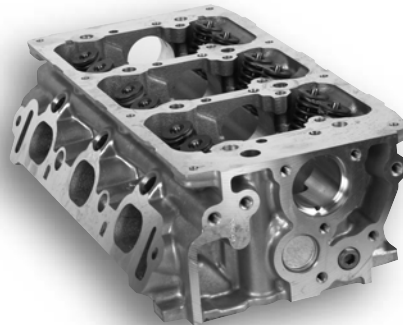

# 3.2L/3.5L ALUMINUM SOHC V6 LONG BLOCK MATRIX

## 3.2L/3.5L ALUMINUM SOHC CYLINDER HEAD MATRIX

MODEL YEAR	ENGINE	CYLINDER HEAD	CAMSHAFT(S)	VALVES AND SPRINGS	ROCKER ARMS	ROCKER SHAFTS	TAPPETS	LASH ADJUSTERS	SPARK PLUG TUBES	CYL. HEAD GASKET	INSTALLER'S GASKET SET	CARDBOARD BOX
2001-98	3.2L SOHC Aluminum	x		x					x		x	x
2004-98	3.5L SOHC Aluminum	x										x

## 3.2L/3.5L ALUMINUM SOHC CYLINDER HEAD MATRIX

MODEL YEAR	ENGINE	CYLINDER BLOCK	CYLINDER HEAD(S)	CRANKSHAFT	MAIN & ROD BEARINGS	CONNECTING ROD SET	PISTON, PIN, RINGS SET	INTERMEDIATE SHAFT	CAMSHAFT(S)	BALANCE SHAFT SYSTEM	VALVES AND SPRINGS	ROCKER ARMS	ROCKER SHAFTS	PUSH RODS	TAPPETS	LASH ADJUSTERS	SPARK PLUG TUBES	TIMING BELT SYSTEM	TIMING CHAIN SYSTEM	CYL. HEAD GASKET(S)	V. COVER(S) W/GASKETS	OIL PUMP	OIL PICKUP	OIL PAN	FRONT TIMING COVER	TIMING INNER COVER	ALTERNATOR BRACKET	WATER PUMP	INSTALLER'S GASKET SET	RETURNABLE CONTAINER	CARDBOARD BOX	WOODEN BOX	
2002-98	3.2L SOHC Aluminum	x	x	x	x	x	x		x		x	x	x		x		x	x															
2004-98	3.5L SOHC Aluminum	x	x	x	x	x	x		x		x	x	x		x		x	x															

## 3.2L/3.5L ALUMINUM SOHC V6 LONG BLOCK MATRIX

## 3.3L/3.8L V6 LONG BLOCK



### PRODUCT FEATURES:

- New Pistons, Pins and Rings
- New Timing Chain
- New Main, Connecting Rod, and Cam Bearings
- New Lifters
- New Gaskets and Seals
- Timing Chain Cover w/Oil Pump
- Gasket Pack Includes:
  - > *PLENUM INTAKE MANIFOLD GASKET*
  - > *WATER PUMP SEAL*
  - > *INTAKE MANIFOLD GASKET*
  - > *CRANKSHAFT SPROCKET WASHER*
  - > *CRANKSHAFT SPROCKET SCREW*
- Remanufactured Block
- Remanufactured Cylinder Heads
- Remanufactured Crankshaft
- Remanufactured Connecting Rods
- Remanufactured Camshaft
- Remanufactured Oil Pump
- Remanufactured Valves
- Remanufactured Valve Covers
- Remanufactured Oil Pan and Pickup Tube

All other components are remanufactured to DaimlerChrysler Engineering specifications or replaced with O.E. parts.

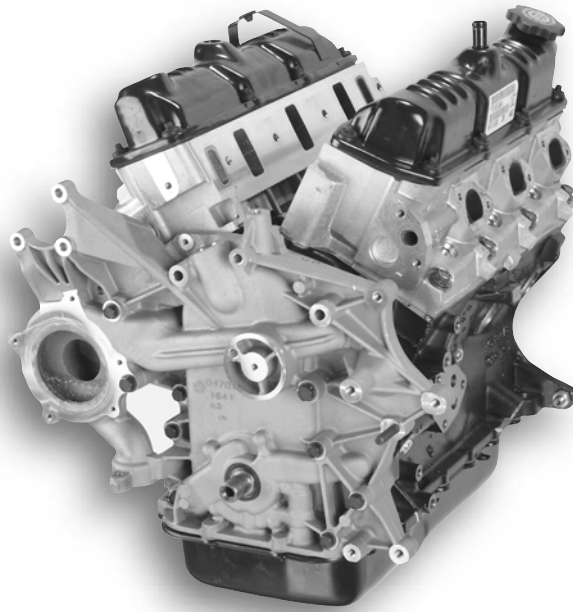

## 3.3L/3.8L CYLINDER HEAD

### PRODUCT FEATURES:

- Remanufactured Cylinder Head
- Rocker Shaft
- Rockers
- Remanufactured Valves and Springs
- 100% Vacuum Leak Tested to Ensure Reliable and Dependable Performance
- Cylinder Head Gasket – Order Separately



# 3.3L/3.8L V6 LONG BLOCK 3.3L/3.8L CYLINDER HEAD MATRIX

MODEL YEAR	ENGINE	
2003-90	3.3L/3.8L OHV	
x		CYLINDER HEAD
		CAMSHAFT(S)
x		VALVES AND SPRINGS
x		ROCKER ARMS
x		ROCKER SHAFTS
		TAPPETS
		LASH ADJUSTERS
		SPARK PLUG TUBES
		CYL. HEAD GASKET
		INSTALLER'S GASKET SET
x		CARDBOARD BOX

## 3.3L/3.8L CYLINDER HEAD MATRIX

MODEL YEAR	ENGINE		
2003-90	3.3L OHV		
2003-91	3.8L OHV		
x		x	CYLINDER BLOCK
x		x	CYLINDER HEAD(S)
x		x	CRANKSHAFT
x		x	MAIN & ROD BEARINGS
x		x	CONNECTING ROD SET
x		x	PISTON, PIN, RINGS SET
			INTERMEDIATE SHAFT
x		x	CAMSHAFT(S)
			BALANCE SHAFT SYSTEM
x		x	VALVES AND SPRINGS
x		x	ROCKER ARMS
x		x	ROCKER SHAFTS
x		x	PUSH RODS
x		x	TAPPETS
			LASH ADJUSTERS
			SPARK PLUG TUBES
			TIMING BELT SYSTEM
x		x	TIMING CHAIN SYSTEM
x		x	CYL. HEAD GASKET(S)
x		x	V. COVER(S) W/GASKETS
x		x	OIL PUMP
x		x	OIL PICKUP
x		x	OIL PAN
x		x	FRONT TIMING COVER
			TIMING INNER COVER
			ALTERNATOR BRACKET
			WATER PUMP
x		x	INSTALLER'S GASKET SET
			RETURNABLE CONTAINER
			CARDBOARD BOX
x		x	WOODEN BOX

## 3.3L/3.8L V6 LONG BLOCK MATRIX

# 1993–97 3.5L V6—LONG BLOCK (CAST IRON)



## PRODUCT FEATURES:

- New Pistons, Pins and Rings
- New Timing Belt and Tensioner
- New Main and Connecting Rod Bearings
- New Freeze Plugs
- New Gaskets and Seals
- New Water Pump
- Timing Belt Covers
- Gasket Pack Includes:
  - > WATER OUTLET GASKET
  - > PLENUM INTAKE MANIFOLD GASKET
  - > INTAKE MANIFOLD GASKET
  - > FUEL RAIL GASKET
  - > CRANKSHAFT SPROCKET SCREW
  - > CRANKSHAFT SPROCKET WASHER
- Remanufactured Block
- Remanufactured Cylinder Heads
- Remanufactured Crankshaft
- Remanufactured Connecting Rods
- Remanufactured Oil Pump
- Remanufactured Valves
- Remanufactured Valve Covers
- Remanufactured Oil Pan and Pickup Tube
- Remanufactured Camshafts

All other components are remanufactured to DaimlerChrysler Engineering specifications or replaced with O.E. parts.

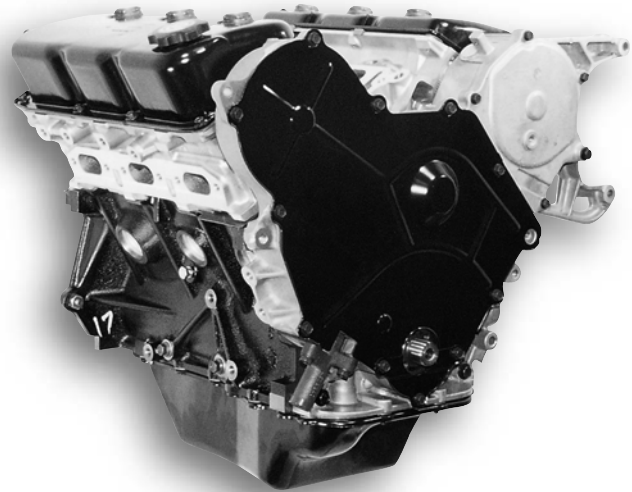

## 3.5L CYLINDER HEAD

## PRODUCT FEATURES:

- Remanufactured Cylinder Head
- Remanufactured Camshaft
- Remanufactured Rocker Arms
- Remanufactured Intake & Exhaust Valves
- Remanufactured Rocker Shafts and Pedestals
- Remanufactured Springs
- 100% Vacuum Leak Tested to Ensure Reliable and Dependable Performance
- Spark Plug Tubes
- Gasket Pack Includes:
  - > PLENUM INTAKE MANIFOLD GASKET
  - > INTAKE MANIFOLD GASKET (2)
  - > CYLINDER HEAD COVER GASKET
  - > CYLINDER HEAD GASKET
  - > THRUST PLATE O-RING
  - > FUEL RAIL GASKET (2)
  - > SPARK PLUG TUBE SEAL (3)





## 3.5L LONG BLOCK MATRIX

### 3.5L CYLINDER HEAD MATRIX

MODEL YEAR	ENGINE	
1997-93	3.5L SOHC Iron	
x		CYLINDER HEAD
x		CAMSHAFT(S)
x		VALVES AND SPRINGS
x		ROCKER ARMS
x		ROCKER SHAFTS
x		TAPPETS
		LASH ADJUSTERS
x		SPARK PLUG TUBES
x		CYL. HEAD GASKET
x		INSTALLER'S GASKET SET
x		CARDBOARD BOX

### 3.5L CYLINDER HEAD MATRIX

MODEL YEAR	ENGINE	
1997-93	3.5L SOHC Iron	
x		CYLINDER BLOCK
x		CYLINDER HEAD(S)
x		CRANKSHAFT
x		MAIN & ROD BEARINGS
x		CONNECTING ROD SET
x		PISTON, PIN, RINGS SET
		INTERMEDIATE SHAFT
x		CAMSHAFT(S)
		BALANCE SHAFT SYSTEM
x		VALVES AND SPRINGS
x		ROCKER ARMS
x		ROCKER SHAFTS
		PUSH RODS
x		TAPPETS
		LASH ADJUSTERS
x		SPARK PLUG TUBES
x		TIMING BELT SYSTEM
		TIMING CHAIN SYSTEM
x		CYL. HEAD GASKET(S)
x		V. COVER(S) W/GASKETS
x		OIL PUMP
x		OIL PICKUP
x		OIL PAN
x		FRONT TIMING COVER
x		TIMING INNER COVER
		ALTERNATOR BRACKET
x		WATER PUMP
x		INSTALLER'S GASKET SET
		RETURNABLE CONTAINER
x		CARDBOARD BOX
		WOODEN BOX

### 3.5L LONG BLOCK MATRIX

## 3.7L LONG BLOCK (CAST IRON)



### PRODUCT FEATURES:

- New Pistons, Pins and Rings
- New Timing Chain
- New Main and Connecting Rod Bearings
- New Lifters
- New Freeze Plugs
- Timing Chain Cover with Oil Pump
- Gasket Pack Includes:
  - > *PLENUM INTAKE MANIFOLD GASKET*
  - > *WATER PUMP SEAL*
  - > *INTAKE MANIFOLD GASKET*
- Remanufactured Cylinder Block
- Remanufactured Cylinder Heads
- Remanufactured Crankshaft
- Remanufactured Connecting Rods
- Remanufactured Oil Pump
- Remanufactured Valves

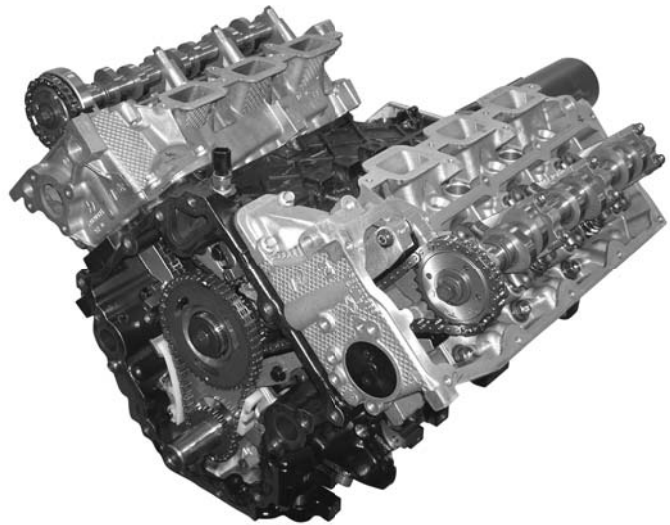

## 3.7L CYLINDER HEAD

### PRODUCT FEATURES:

- Remanufactured Valves and Springs
- 100% Vacuum Leak Tested to Ensure Reliable and Dependable Performance
- Cylinder Head Gasket

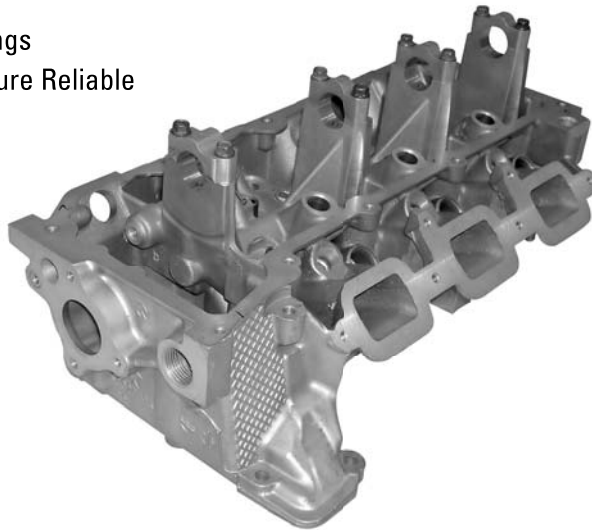

## 3.7L LONG BLOCK MATRIX

### 3.7L CYLINDER HEAD MATRIX

MODEL YEAR	ENGINE	
2004-02	3.7L SOHC	
		<b>CYLINDER HEAD</b>
		<b>CAMSHAFT(S)</b>
		<b>VALVES AND SPRINGS</b>
		<b>ROCKER ARMS</b>
		<b>ROCKER SHAFTS</b>
		<b>TAPPETS</b>
		<b>LASH ADJUSTERS</b>
		<b>SPARK PLUG TUBES</b>
		<b>CYL. HEAD GASKET</b>
		<b>INSTALLER'S GASKET SET</b>
		<b>CARDBOARD BOX</b>

### 3.7L CYLINDER HEAD MATRIX

MODEL YEAR	ENGINE	
2004-02	3.7L SOHC	
		<b>CYLINDER BLOCK</b>
		<b>CYLINDER HEAD(S)</b>
		<b>CRANKSHAFT</b>
		<b>MAIN &amp; ROD BEARINGS</b>
		<b>CONNECTING ROD SET</b>
		<b>PISTON, PIN, RINGS SET</b>
		<b>INTERMEDIATE SHAFT</b>
		<b>CAMSHAFT(S)</b>
		<b>BALANCE SHAFT SYSTEM</b>
		<b>VALVES AND SPRINGS</b>
		<b>ROCKER ARMS</b>
		<b>ROCKER SHAFTS</b>
		<b>PUSH RODS</b>
		<b>TAPPETS</b>
		<b>LASH ADJUSTERS</b>
		<b>SPARK PLUG TUBES</b>
		<b>TIMING BELT SYSTEM</b>
		<b>TIMING CHAIN SYSTEM</b>
		<b>CYL. HEAD GASKET(S)</b>
		<b>V. COVER(S) W/GASKETS</b>
		<b>OIL PUMP</b>
		<b>OIL PICKUP</b>
		<b>OIL PAN</b>
		<b>FRONT TIMING COVER</b>
		<b>TIMING INNER COVER</b>
		<b>ALTERNATOR BRACKET</b>
		<b>WATER PUMP</b>
		<b>INSTALLER'S GASKET SET</b>
		<b>RETURNABLE CONTAINER</b>
		<b>CARDBOARD BOX</b>
		<b>WOODEN BOX</b>

### 3.7L LONG BLOCK MATRIX

# 3.9L V6 LONG BLOCK



## PRODUCT FEATURES:

- New Pistons, Pins and Rings
- New Timing Chain
- New Main, Connecting Rod and Cam Bearings
- New Gaskets and Seals
- New Oil Pump
- New Tappets
- 3.9L Magnum Gasket Pack Includes:
  - > INTAKE DOWELS (4)
  - > EGR GASKET
  - > WATER PUMP GASKET
  - > INTAKE GASKET PACKAGE
  - > OIL PAN GASKET
  - > VALVE COVER GASKETS (2)
  - > EGR TUBE GASKET
  - > THERMOSTAT GASKET
  - > TIMING CHAIN COVER GASKET
  - > THROTTLE BODY GASKET
  - > WATER JACKET PLUGS (2)
  - > FRONT SEAL
- Remanufactured Crankshaft
- Remanufactured Cylinder Heads
- Remanufactured Cylinder Block
- Remanufactured Connecting Rods
- Remanufactured Camshaft
- Remanufactured Valves
- Remanufactured Rocker Arms

## • 3.9L Pre-Magnum Gasket Pack Includes:

- > INTAKE DOWELS (2)
- > EGR GASKET
- > OIL PAN KIT
- > WATER PUMP GASKET
- > RIGHT INTAKE GASKET
- > LEFT INTAKE GASKET
- > REAR INTAKE GASKET
- > VALVE COVER GASKETS (2)
- > EGR TUBE GASKET
- > THERMOSTAT GASKET
- > TIMING CHAIN COVER GASKET
- > THROTTLE BODY GASKET
- > WATER JACKET PLUGS (2)
- > FRONT SEAL

All other components are remanufactured to DaimlerChrysler Engineering specifications or replaced with O.E. parts.

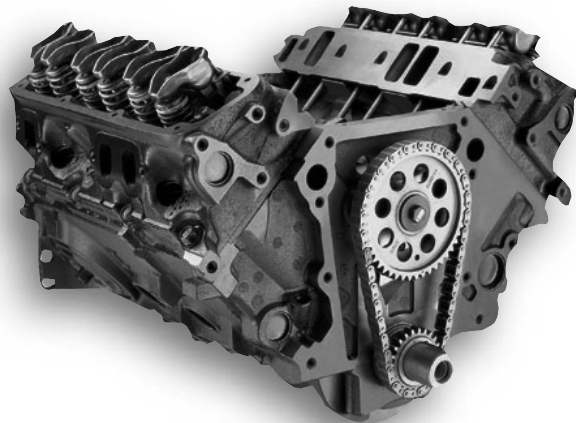

# 3.9L CYLINDER HEAD

## PRODUCT FEATURES:

Note: The 3.9L Magnum Cylinder Head comes complete except for rocker arms and cylinder head gasket, which must be ordered separately.

- Remanufactured Cylinder Head
- Remanufactured Valves
- Remanufactured Springs
- New Seals
- New Freeze Plugs
- 100% Vacuum Leak Tested to Ensure Reliable and Dependable Performance



## 3.9L V6 LONG BLOCK MATRIX

### 3.9L CYLINDER HEAD MATRIX

MODEL YEAR	ENGINE	
2003-86	3.9L OHV	
		<b>CYLINDER HEAD</b>
		<b>CAMSHAFT(S)</b>
		<b>VALVES AND SPRINGS</b>
		<b>ROCKER ARMS</b>
		<b>ROCKER SHAFTS</b>
		<b>TAPPETS</b>
		<b>LASH ADJUSTERS</b>
		<b>SPARK PLUG TUBES</b>
		<b>CYL. HEAD GASKET</b>
		<b>INSTALLER'S GASKET SET</b>
		<b>CARDBOARD BOX</b>

### 3.9L CYLINDER HEAD MATRIX

MODEL YEAR	ENGINE	
2003-92	3.9L OHV	
1991-86	3.9L OHV	
		<b>CYLINDER BLOCK</b>
		<b>CYLINDER HEAD(S)</b>
		<b>CRANKSHAFT</b>
		<b>MAIN &amp; ROD BEARINGS</b>
		<b>CONNECTING ROD SET</b>
		<b>PISTON, PIN, RINGS SET</b>
		<b>INTERMEDIATE SHAFT</b>
		<b>CAMSHAFT(S)</b>
		<b>BALANCE SHAFT SYSTEM</b>
		<b>VALVES AND SPRINGS</b>
		<b>ROCKER ARMS</b>
		<b>ROCKER SHAFTS</b>
		<b>PUSH RODS</b>
		<b>TAPPETS</b>
		<b>LASH ADJUSTERS</b>
		<b>SPARK PLUG TUBES</b>
		<b>TIMING BELT SYSTEM</b>
		<b>TIMING CHAIN SYSTEM</b>
		<b>CYL. HEAD GASKET(S)</b>
		<b>V. COVER(S) W/GASKETS</b>
		<b>OIL PUMP</b>
		<b>OIL PICKUP</b>
		<b>OIL PAN</b>
		<b>FRONT TIMING COVER</b>
		<b>TIMING INNER COVER</b>
		<b>ALTERNATOR BRACKET</b>
		<b>WATER PUMP</b>
		<b>INSTALLER'S GASKET SET</b>
		<b>RETURNABLE CONTAINER</b>
		<b>CARDBOARD BOX</b>
		<b>WOODEN BOX</b>

### 3.9L V6 LONG BLOCK MATRIX

## 4.0L I-6 JEEP® LONG BLOCK



### PRODUCT FEATURES:

- New Pistons, Pins and Rings
- New Timing Chain and Gears
- New Main, Connecting Rod and Cam Bearings
- New Gaskets and Seals
- New Intake and Exhaust Valves
- New Valve Springs
- New Push Rods
- New Oil Pump and Pickup Screen
- New Camshaft and Lifters
- New Core Hole/Expansion Plugs
- Gasket Pack Includes:
  - > WATER PUMP GASKET
  - > THERMOSTAT GASKET
  - > DISTRIBUTOR GASKET
  - > THROTTLE BODY GASKET
  - > INTAKE AND EXHAUST GASKET
  - > VALVE COVER GASKET (1996-UP)
- Remanufactured Crankshaft
- Remanufactured Cylinder Head
- Remanufactured Cylinder Block
- Remanufactured Connecting Rods

All other components are remanufactured to DaimlerChrysler Engineering specifications or replaced with O.E. parts.



## 4.0L JEEP® CYLINDER HEAD

### PRODUCT FEATURES:

- Remanufactured Cylinder Head
- New Intake and Exhaust Valves
- New Seals
- New Freeze Plugs
- 100% Vacuum Leak Tested to Ensure Reliable and Dependable Performance
- Cylinder Head Gasket – Order Separately



# 4.0L I-6 JEEP® LONG BLOCK MATRIX

## 4.0L JEEP® CYLINDER HEAD MATRIX

MODEL YEAR	ENGINE	
2004-87	4.0L	
		X CYLINDER HEAD
		CAMSHAFT(S)
		X VALVES AND SPRINGS
		ROCKER ARMS
		ROCKER SHAFTS
		TAPPETS
		LASH ADJUSTERS
		SPARK PLUG TUBES
		CYL. HEAD GASKET
		INSTALLER'S GASKET SET
		X CARDBOARD BOX

## 4.0L JEEP® CYLINDER HEAD MATRIX

MODEL YEAR	ENGINE	
2004-87	4.0L	
		X CYLINDER BLOCK
		X CYLINDER HEAD(S)
		X CRANKSHAFT
		X MAIN & ROD BEARINGS
		X CONNECTING ROD SET
		X PISTON, PIN, RINGS SET
		INTERMEDIATE SHAFT
		X CAMSHAFT(S)
		BALANCE SHAFT SYSTEM
		X VALVES AND SPRINGS
		X ROCKER ARMS
		ROCKER SHAFTS
		X PUSH RODS
		X TAPPETS
		LASH ADJUSTERS
		SPARK PLUG TUBES
		TIMING BELT SYSTEM
		X TIMING CHAIN SYSTEM
		X CYL. HEAD GASKET(S)
		V. COVER(S) W/GASKETS
		X OIL PUMP
		X OIL PICKUP
		X OIL PAN
		X FRONT TIMING COVER
		TIMING INNER COVER
		ALTERNATOR BRACKET
		WATER PUMP
		X INSTALLER'S GASKET SET
		X RETURNABLE CONTAINER
		CARDBOARD BOX
		WOODEN BOX

## 4.0L I-6 JEEP® LONG BLOCK MATRIX



## 4.7L V8 LONG BLOCK



### PRODUCT FEATURES:

- New Pistons, Pins and Rings
- New Timing Chains, Guides, and Tensioners
- New Main, Connecting Rod Bearings
- New Freeze Plugs
- New Gaskets and Seals
- Gasket Pack Includes:
  - > VALVE COVER GASKETS
  - > WATER OUTLET GASKET
  - > PLENUM INTAKE MANIFOLD GASKET
  - > INTAKE MANIFOLD GASKETS
  - > FUEL RAIL GASKET
- Remanufactured Cylinder Block
- Remanufactured Crankshaft
- Remanufactured Cylinder Heads
- Remanufactured Valves and Springs
- Remanufactured Camshafts (2)
- Remanufactured Rocker Arms (16)
- Remanufactured Oil Pump
- Remanufactured Connecting Rods

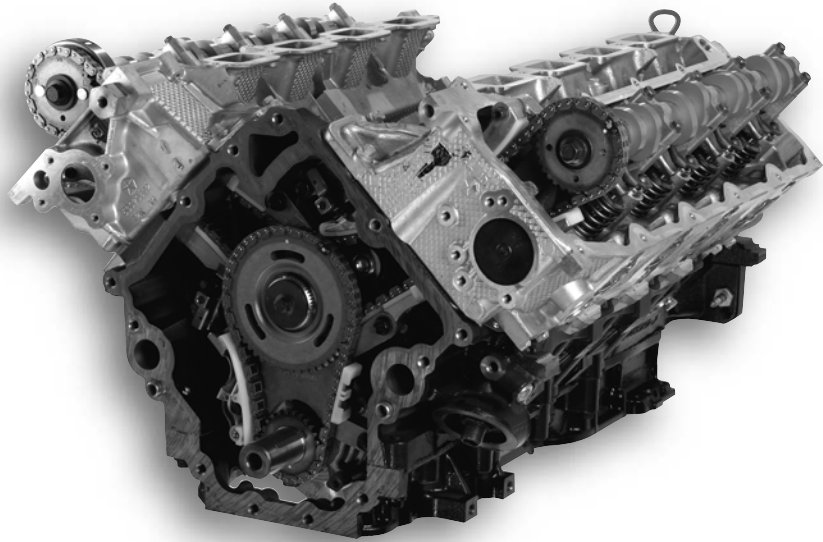

## 4.7L CYLINDER HEAD

### PRODUCT FEATURES:

- Remanufactured Valves and Springs
- 100% Vacuum Leak Tested to Ensure Reliable and Dependable Performance
- Cylinder Head Gasket

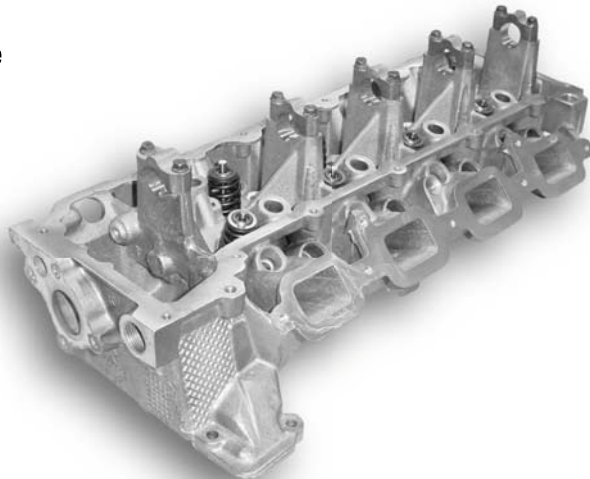

# 4.7L V8 LONG BLOCK MATRIX

## 4.7L CYLINDER HEAD MATRIX

MODEL YEAR	ENGINE	CYLINDER HEAD	CAMSHAFT(S)	VALVES AND SPRINGS	ROCKER ARMS	ROCKER SHAFTS	TAPPETS	LASH ADJUSTERS	SPARK PLUG TUBES	CYL. HEAD GASKET	INSTALLER'S GASKET SET	CARDBOARD BOX
2004-99	4.7L SOHC	X		X						X		X

## 4.7L CYLINDER HEAD MATRIX

MODEL YEAR	ENGINE	CYLINDER BLOCK	CYLINDER HEAD(S)	CRANKSHAFT	MAIN & ROD BEARINGS	CONNECTING ROD SET	PISTON, PIN, RINGS SET	INTERMEDIATE SHAFT	CAMSHAFT(S)	BALANCE SHAFT SYSTEM	VALVES AND SPRINGS	ROCKER ARMS	ROCKER SHAFTS	PUSH RODS	TAPPETS	LASH ADJUSTERS	SPARK PLUG TUBES	TIMING BELT SYSTEM	TIMING CHAIN SYSTEM	CYL. HEAD GASKET(S)	V. COVER(S) W/GASKETS	OIL PUMP	OIL PICKUP	OIL PAN	FRONT TIMING COVER	TIMING INNER COVER	ALTERNATOR BRACKET	WATER PUMP	INSTALLER'S GASKET SET	RETURNABLE CONTAINER	CARDBOARD BOX	WOODEN BOX
2004-02	4.7L WJ (High Output)	X	X	X	X	X	X		X			X			X				X	X						X					X	
2002.5	4.7L DN (w/NGC)	X	X	X	X	X	X		X			X			X				X	X						X					X	
2002	4.7L DR	X	X	X	X	X	X		X			X			X				X	X						X					X	
2002-01	4.7L AN, DN (JTEC Only)	X	X	X	X	X	X		X			X			X				X	X						X					X	
2002-99	4.7L WJ	X	X	X	X	X	X		X			X			X				X	X						X					X	

## 4.7L V8 LONG BLOCK MATRIX

## 5.2L V8 LONG BLOCK



### PRODUCT FEATURES:

- New Pistons, Pins and Rings
- New Timing Chain
- New Main, Connecting Rod and Cam Bearings
- New Gaskets and Seals
- New Oil Pump
- New Tappets

#### 5.2L Magnum Long Block

##### Gasket Pack Includes:

- > INTAKE DOWELS (4)
- > WATER PUMP GASKET
- > INTAKE GASKET PACKAGE
- > OIL PAN GASKET
- > VALVE COVER GASKETS (2)
- > EGR TUBE GASKET
- > THERMOSTAT GASKET
- > TIMING CHAIN COVER GASKET
- > THROTTLE BODY GASKET
- > WATER JACKET PLUGS (2)
- > FRONT SEAL
- > EGR VALVE GASKET

All other components are remanufactured to DaimlerChrysler Engineering specifications or replaced with O.E. parts.

- Remanufactured Crankshaft
- Remanufactured Cylinder Heads
- Remanufactured Cylinder Block
- Remanufactured Connecting Rods
- Remanufactured Camshaft
- Remanufactured Rocker Arms
- Remanufactured Valves

#### 5.2L Pre-Magnum Long Block

##### Gasket Pack Includes:

- > INTAKE DOWELS (2)
- > WATER PUMP GASKET
- > INTAKE GASKET PACKAGE
- > OIL PAN GASKET KIT
- > VALVE COVER GASKETS (2)
- > EGR VALVE GASKET
- > THERMOSTAT GASKET
- > TIMING CHAIN COVER GASKET
- > THROTTLE BODY GASKET
- > EGR TUBE GASKET
- > FRONT SEAL

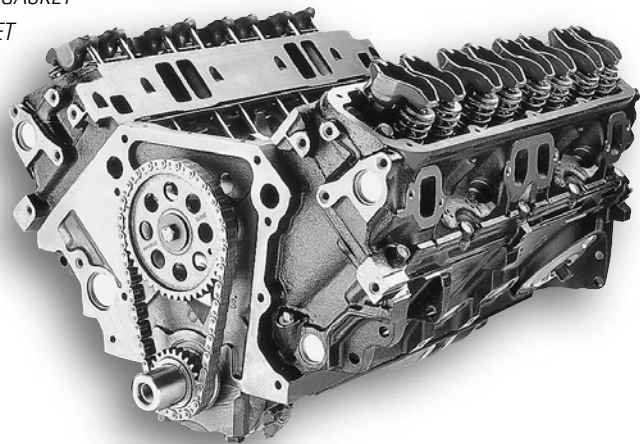

## 5.2L CYLINDER HEAD

### PRODUCT FEATURES:

Note: The 5.2L Magnum Cylinder Head comes complete except for rocker arms and cylinder head gasket, which must be ordered separately.

- Remanufactured Cylinder Head
- Remanufactured Valve Springs
- New Freeze Plugs
- Remanufactured Valves
- New Seals
- 100% Vacuum Leak Tested to Ensure Reliable and Dependable Performance



## 5.2L V8 LONG BLOCK MATRIX

### 5.2L CYLINDER HEAD MATRIX

MODEL YEAR	ENGINE	
2003-75	5.2L OHV	
		<b>CYLINDER HEAD</b>
		<b>CAMSHAFT(S)</b>
		<b>VALVES AND SPRINGS</b>
		<b>ROCKER ARMS</b>
		<b>ROCKER SHAFTS</b>
		<b>TAPPETS</b>
		<b>LASH ADJUSTERS</b>
		<b>SPARK PLUG TUBES</b>
		<b>CYL. HEAD GASKET</b>
		<b>INSTALLER'S GASKET SET</b>
		<b>CARDBOARD BOX</b>

### 5.2L CYLINDER HEAD MATRIX

MODEL YEAR	ENGINE	
2003-92	5.2L OHV	
1991-75	5.2L OHV	
		<b>CYLINDER BLOCK</b>
		<b>CYLINDER HEAD(S)</b>
		<b>CRANKSHAFT</b>
		<b>MAIN &amp; ROD BEARINGS</b>
		<b>CONNECTING ROD SET</b>
		<b>PISTON, PIN, RINGS SET</b>
		<b>INTERMEDIATE SHAFT</b>
		<b>CAMSHAFT(S)</b>
		<b>BALANCE SHAFT SYSTEM</b>
		<b>VALVES AND SPRINGS</b>
		<b>ROCKER ARMS</b>
		<b>ROCKER SHAFTS</b>
		<b>PUSH RODS</b>
		<b>TAPPETS</b>
		<b>LASH ADJUSTERS</b>
		<b>SPARK PLUG TUBES</b>
		<b>TIMING BELT SYSTEM</b>
		<b>TIMING CHAIN SYSTEM</b>
		<b>CYL. HEAD GASKET(S)</b>
		<b>V. COVER(S) W/GASKETS</b>
		<b>OIL PUMP</b>
		<b>OIL PICKUP</b>
		<b>OIL PAN</b>
		<b>FRONT TIMING COVER</b>
		<b>TIMING INNER COVER</b>
		<b>ALTERNATOR BRACKET</b>
		<b>WATER PUMP</b>
		<b>INSTALLER'S GASKET SET</b>
		<b>RETURNABLE CONTAINER</b>
		<b>CARDBOARD BOX</b>
		<b>WOODEN BOX</b>

### 5.2L V8 LONG BLOCK MATRIX

# 5.9L V8 LONG BLOCK



## PRODUCT FEATURES:

- New Pistons, Pins and Rings
- New Timing Chain
- New Main, Connecting Rod and Cam Bearings
- New Gaskets and Seals
- New Oil Pump
- New Tappets
- 5.9L Magnum Long Block Gasket Pack Includes:
  - > EGR TUBE GASKET
  - > INTAKE DOWELS (4)
  - > WATER PUMP GASKET
  - > OIL PAN GASKET
  - > VALVE COVER GASKETS (2)
  - > THERMOSTAT GASKET
  - > TIMING CHAIN COVER GASKET
  - > THROTTLE BODY GASKET
  - > WATER JACKET PLUGS (2)
  - > FRONT SEAL
  - > EGR VALVE GASKET
  - > INTAKE GASKET PACKAGE
- Remanufactured Crankshaft
- Remanufactured Cylinder Heads
- Remanufactured Cylinder Block
- Remanufactured Connecting Rods
- Remanufactured Camshaft
- Remanufactured Rocker Arms
- Remanufactured Valves

## • 5.9L Pre-Magnum Long Block Gasket Pack Includes:

- > INTAKE DOWELS (6)
- > EGR VALVE GASKET
- > WATER PUMP GASKET
- > INTAKE GASKET PACKAGE
- > VALVE COVER GASKETS (2)
- > EGR TUBE GASKET
- > TIMING CHAIN COVER GASKET
- > THROTTLE BODY GASKET
- > OIL PAN GASKET
- > FRONT SEAL

All other components are remanufactured to DaimlerChrysler Engineering specifications or replaced with O.E. parts.

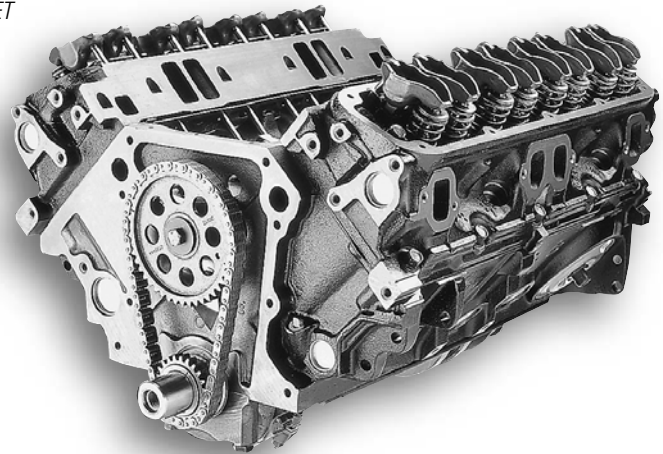

# 5.9L CYLINDER HEAD

## PRODUCT FEATURES:

Note: The 5.9L Magnum Cylinder Head comes complete except for rocker arms and cylinder head gasket, which must be ordered separately.

- Remanufactured Cylinder Head
- Remanufactured Valve Springs
- New Freeze Plugs
- Remanufactured Valves
- New Seals
- 100% Vacuum Leak Tested to Ensure Reliable and Dependable Performance





# 8.0L V10 MAGNUM LONG BLOCK



## PRODUCT FEATURES:

- New Pistons, Pins and Rings
- New Timing Chain
- New Main, Connecting Rod and Cam Bearings
- New Lifters
- New Gaskets and Seals
- Gasket Pack Includes:
  - > WATER OUTLET GASKET
  - > UPPER INTAKE GASKET
  - > EXHAUST MANIFOLD GASKETS (2)
  - > VALVE COVER GASKETS
  - > INTAKE GASKETS (2)
  - > INTAKE SEALS (2)
  - > THROTTLE BODY GASKET
  - > EGR VALVE GASKET (94-95 ONLY)
  - > EGR TUBE GASKET (94-95 ONLY)
- Remanufactured Crankshaft
- Remanufactured Cylinder Heads
- Remanufactured Cylinder Block
- Remanufactured Connecting Rods
- Remanufactured Front Cover
- Remanufactured Oil Pump
- Remanufactured Oil Pan
- Remanufactured Camshaft
- Remanufactured Rocker Arms
- Remanufactured Valves

All other components are remanufactured to DaimlerChrysler Engineering specifications or replaced with O.E. parts.

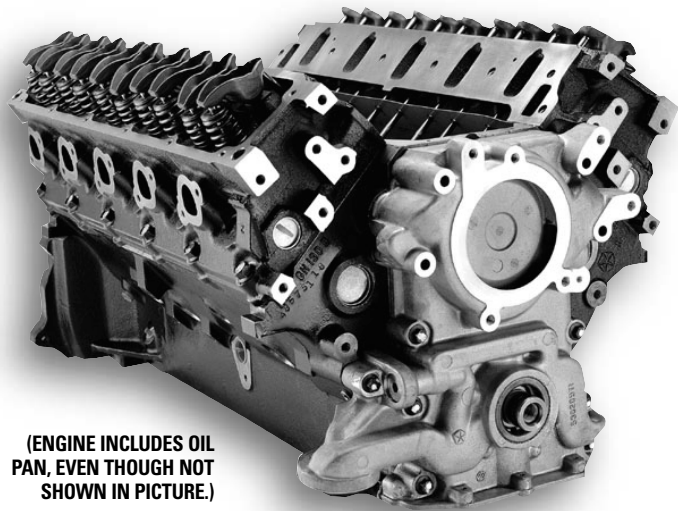

(ENGINE INCLUDES OIL PAN, EVEN THOUGH NOT SHOWN IN PICTURE.)

# 8.0L CYLINDER HEAD

## PRODUCT FEATURES:

Note: The 8.0L Magnum cylinder head comes complete except for cylinder head gasket. Refer to Tech Tips for additional details.

- Remanufactured Cylinder Head
- Remanufactured Valves
- New Springs
- Remanufactured Rocker Arms
- New Seals
- New Freeze Plugs
- 100% Vacuum Leak Tested to Ensure Reliable and Dependable Performance



# 8.0L V10 MAGNUM LONG BLOCK MATRIX

## 8.0L CYLINDER HEAD MATRIX

MODEL YEAR	ENGINE	
2003-94	8.0L OHV Iron	
X		CYLINDER HEAD
		CAMSHAFT(S)
X		VALVES AND SPRINGS
X		ROCKER ARMS
		ROCKER SHAFTS
		TAPPETS
		LASH ADJUSTERS
		SPARK PLUG TUBES
		CYL. HEAD GASKET
		INSTALLER'S GASKET SET
X		CARDBOARD BOX

## 8.0L CYLINDER HEAD MATRIX

MODEL YEAR	ENGINE	
2003-94	8.0L OHV Iron	
X		CYLINDER BLOCK
X		CYLINDER HEAD(S)
X		CRANKSHAFT
X		MAIN & ROD BEARINGS
X		CONNECTING ROD SET
X		PISTON, PIN, RINGS SET
		INTERMEDIATE SHAFT
X		CAMSHAFT(S)
		BALANCE SHAFT SYSTEM
X		VALVES AND SPRINGS
X		ROCKER ARMS
		ROCKER SHAFTS
X		PUSH RODS
X		TAPPETS
		LASH ADJUSTERS
		SPARK PLUG TUBES
		TIMING BELT SYSTEM
X		TIMING CHAIN SYSTEM
X		CYL. HEAD GASKET(S)
		V. COVER(S) W/GASKETS
X		OIL PUMP
X		OIL PICKUP
X		OIL PAN
X		FRONT TIMING COVER
		TIMING INNER COVER
		ALTERNATOR BRACKET
		WATER PUMP
X		INSTALLER'S GASKET SET
X		RETURNABLE CONTAINER
		CARDBOARD BOX
		WOODEN BOX

## 8.0L V10 MAGNUM LONG BLOCK MATRIX



## 4.0L I-6 JEEP® SHORT BLOCK



### PRODUCT FEATURES:

- New Pistons, Pins and Rings
- New Timing Chain and Gears
- New Main, Connecting Rod and Cam Bearings
- New Gaskets and Seals
- New Oil Pump and Pickup Screen
- New Camshaft
- New Core Hole/Expansion Plugs
- Gasket Pack Includes:
  - > WATER PUMP GASKET
  - > THERMOSTAT GASKET
  - > DISTRIBUTOR GASKET
  - > THROTTLE BODY GASKET
  - > HEAD GASKET
- Remanufactured Crankshaft
- Remanufactured Cylinder Block
- Remanufactured Connecting Rods

All other components are remanufactured to DaimlerChrysler Engineering specifications or replaced with O.E. parts.

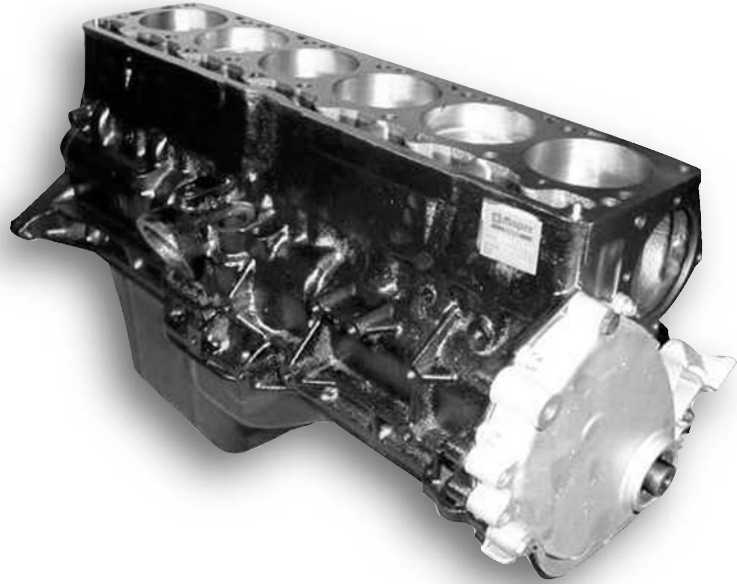

## 4.0L I-6 JEEP® SHORT BLOCK MATRIX

MODEL YEAR	
2001-92	
ENGINE	
4.0L I-6	
x	CYLINDER BLOCK
x	CRANKSHAFT
x	MAIN & ROD BEARINGS
x	CONNECTING ROD SET
x	PISTON, PIN, RINGS SET
x	CAMSHAFT(S)
x	CYL. HEAD GASKET(S)
x	OIL PUMP
x	OIL PICKUP
x	OIL PAN
x	FRONT TIMING COVER
x	INSTALLER'S GASKET SET
x	RETURNABLE CONTAINER

## 4.0L I-6 JEEP® SHORT BLOCK MATRIX

## 5.2L MAGNUM SHORT BLOCK



### PRODUCT FEATURES:

- New Pistons, Pins and Rings
- New Bearings

Gasket Pack Not Included.

All other components are remanufactured to DaimlerChrysler Engineering specifications or replaced with O.E. parts.

- Remanufactured Crankshaft
- Remanufactured Cylinder Block
- Remanufactured Connecting Rods

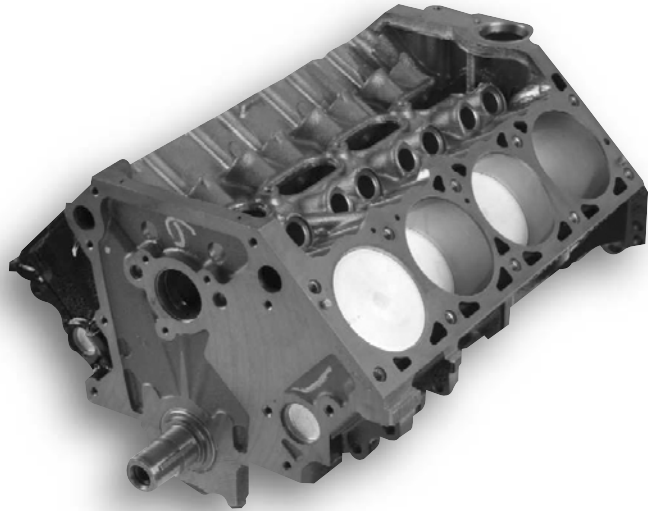

## 5.9L MAGNUM SHORT BLOCK

### PRODUCT FEATURES:

- New Pistons, Pins and Rings
- New Bearings

Gasket Pack Not Included.

All other components are remanufactured to DaimlerChrysler Engineering specifications or replaced with O.E. parts.

- Remanufactured Crankshaft
- Remanufactured Cylinder Block
- Remanufactured Connecting Rods



## 5.2L/5.9L MAGNUM SHORT BLOCK MATRIX

		<b>5.2L/5.9L MAGNUM SHORT BLOCK MATRIX</b>	
<b>MODEL YEAR</b>	<b>ENGINE</b>		
2003-92	5.2L		
2003-93	5.9L		
x	x	<b>CYLINDER BLOCK</b>	
x	x	<b>CRANKSHAFT</b>	
x	x	<b>MAIN &amp; ROD BEARINGS</b>	
x	x	<b>CONNECTING ROD SET</b>	
x	x	<b>PISTON, PIN, RINGS SET</b>	
x	x	<b>CARDBOARD BOX</b>	

# LONG BLOCK ENGINES



## PASSENGER CARS

MODEL YEARS	APPLICATION/ENGINE DISPLACEMENT	REMAN PART NO.
2005-03	2.0L SOHC Fed & LEV	R0420435AA
2004-03	2.0L SOHC RT	R0420534AA
2002-00	2.0L SOHC Fed & LEV	R0420402AA
2002	2.0L SOHC RT	R0420522AA
2001	2.0L SOHC RT	R0420511AA
1999-98	2.0L SOHC LEV	R0420469AA
1999-96	2.0L SOHC Fed	R0420469AA
1999-95	2.0L DOHC (rear exhaust no oil pan; no valve cover)	R0420857AA
1999-95	2.0L DOHC (front exhaust no oil pan; no valve cover)	R0420847AA
1997-96	2.0L SOHC TLEV	R0420767AA
1995	2.0L SOHC 16V (ECH) TLEV (no oil pan; no valve cover)	R0420755AA
1995-94	2.0L SOHC 16V (ECB) FED (no oil pan; no valve cover)	R0420445AA
1995-89	2.2L EFI (EDF) rollers	R0522092
1988	2.2L EFI (EDF) rollers	R0522088
1988	2.2L Turbo I (EDG) rollers	R0522188
1988	2.2L Turbo II (EDR) rollers	R0522288
1987-86	2.2L Turbo I (EDG)	R0522002
1985	2.2L Turbo I (EDG)	R0522001
1984-83	2.2L Carb. (EDE)	R0501221
2002	2.4L PT without EGR DOHC	R3424722AA
2002	2.4L PT with EGR DOHC	R3424822AA
2002	2.4L JR DOHC	R0424822AA
2001	2.4L PT DOHC	R3424811AA
2001	2.4L JR DOHC	R0424811AA
2000-98	2.4L DOHC (no oil pan; no valve cover)	R0424880AA
1997-96.5	2.4L DOHC (no oil pan; no valve cover)	R0424867AA
1996.5-95	2.4L DOHC (no oil pan; no valve cover) (hydr belt tensioner)	R0424857AA
2000-98	2.5L SOHC V6	R0625480
1997-95	2.5L SOHC V6	R0625457
1995-89	2.5L EFI (EDM) rollers	R0525092
1992-89	2.5L Turbo (EDT) rollers	R0525192
1988	2.5L EFI (EDM) rollers	R0525088
1987-86	2.5L TBI (EDM)	R0532567
2004	2.7L DOHC JR Body (w/NGC Controller)	R1627024
2003-01	2.7L DOHC (JR only) (w JTEC Controller)	R1627001
2004-02	2.7L LH Body (NGC Controller)	R1627024
2001-00	2.7L DOHC (LH Body) (w JTEC Controller)	R1627001
1999-98	2.7L DOHC (LH Body)	R1627089
2000-98	3.0L (EFA) rollers	R0630045
1997-91	3.0L (EFA) rollers	R0630013
1990-87	3.0L Converted to rollers (EFA)	R0630070

Note: R0630070 uses roller rocker arms. Original equipment uses slider-type rocker arms. The sticker provided with the Mopar Reman engine must be placed on the valve cover to identify it as a roller-type rocker engine.

# LONG BLOCK ENGINES

(CONTINUED)



## PASSENGER CARS (CONT.)

MODEL YEARS	APPLICATION/ENGINE DISPLACEMENT	REMAN PART NO.
2001-98	3.2L SOHC LH Body (aluminum block)	R1632488
1997-93.5	3.3L LH Body (EGB) Head Casting no. 4621510	R1633436
1994-93.5	3.3L (EGA) all exc. LH Body, Head Casting no. 4621510	R0633435
1993.5-93	3.3L LH Body (EGB) Head Casting no. 4448015	R1633433
1993.5-90	3.3L (EGA) all exc. LH Body, Head Casting no. 4448015	R0633403
2004-02	3.5L SOHC LH Body (aluminum block)	R1635024
2001-98	3.5L SOHC LH Body (aluminum block)	R1635488
1997-95	3.5L LH Body (EGE)	R1635457
1994-93	3.5L LH Body (EGE)	R1635434
1987-81	3.7L Federal w/cast crank & hydraulic lifter (Slant 6 225 CID)	R0501707AA
1993.5-91	3.8L Car (EGH) Head Casting no. 4448015	R0638413
1990-85	5.2L All passenger cars w/roller lifter	R2852250
1989-85	5.2L All passenger cars non-roller	R2852057
1984-75	5.2L All passenger cars non-roller	R2852054
1989-75	5.9L All passenger cars	R2859059

## MINIVANS

MODEL YEARS	APPLICATION/ENGINE DISPLACEMENT	REMAN PART NO.
1993-89	2.2L (EDF) rollers	R0522092
1988	2.2L (EDF) rollers	R0522088
2002	2.4L RS	R0424822AA
2001	2.4L RS	R0424811AA
2000-98	2.4L DOHC (no oil pan; no valve cover)	R0424880AA
1997-96.5	2.4L DOHC (no oil pan; no valve cover)	R0424867AA
1996.5-95	2.4L DOHC (no oil pan; no valve cover) (hydr belt tensioner)	R0424857AA
1995-89	2.5L EFI (EDM) rollers	R0525092
1989	2.5L Turbo (EDT) rollers	R0525192
2000-98	3.0L (EFA) rollers	R0630045
1997-91	3.0L (EFA) rollers	R0630013
1990-87	3.0L (EFA) converted to rollers	R0630070
2003-01	3.3L	R0633411
2000-98	3.3L	R0633480
1997-96	3.3L (EGA) Head Casting no. 4621510	R0633466
1995-93.5	3.3L (EGA) Head Casting no. 4621510	R0633435
1993.5-90	3.3L (EGA) Head Casting no. 4448015	R0633403
2003-01	3.8L	R0638411
2000-98	3.8L	R0638480
1997-96	3.8L (EGH) Head Casting no. 4621510	R0638466
1995-93.5	3.8L (EGH) Head Casting no. 4621510	R0638435
1993.5-91	3.8L (EGH) Head Casting no. 4448015	R0638413

Note: R0630070 uses roller rocker arms. Original equipment uses slider-type rocker arms. The sticker provided with the Mopar Reman engine must be placed on the valve cover to identify it as a roller-type rocker engine.

# LONG BLOCK ENGINES

(CONTINUED)



## TRUCKS & VANS

MODEL YEARS	APPLICATION/ENGINE DISPLACEMENT	REMAN PART NO.
1988	2.2L Carb. rollers, overhead cam eng.	RT522088
2001-96	2.5L Truck	R2425319AA
1995-88	2.5L Truck rollers, overhead cam eng.	RT525094
2003-01	2.7L Diesel for Sprinter Vans	R2527513AA
2004	3.7L V-6 AN, HB, DR	R2637044
2003-02	3.7L V-6 DR	R2637023
1987-81	3.7L Federal w/cast crank & hydraulic lifter (Slant 6 225 CID)	R0501707AA
2003-98	3.9L V6 Magnum	R2639480
1997-92	3.9L V6 Magnum	R2639224
1991-88	3.9L V6 w/roller lifters	R2639281
1988-86	3.9L V6 non-roller	R2639067
2002.5	4.7L SOHC V8 DN (w/NGC Controller)	R2847024
2002	4.7L SOHC V8 (DR only)	R2847014
2002-01	4.7L SOHC V8 AN, DN, (JTEC Controller only)	R2847014
2002-01	4.7L SOHC V8 WJ, AN, DN, DR	R2847014
2003-98	5.2L V8 Magnum	R2852480
1997-92	5.2L V8 Magnum	R2852424
1991	5.2L V8 w/roller lifters	R2852211
1990-85	5.2L V8 w/roller lifters	R2852250
1989-85	5.2L V8 non-roller	R2852057
1984-75	5.2L V8 non-roller	R2852054
2005-03	5.7L Hemi	R5142306AB
2003-02	5.9L V8 Magnum (DR only)	R2859423
2003-98	5.9L V8 Magnum	R2859488
1997-93	5.9L V8 Magnum	R2859436
1992-85	5.9L V8 w/roller lifters	R2859292
1989-75	5.9L V8 non-roller	R2859059
2003	8.0L DR	R2080433
2002-96	8.0L V10 (BR only)	R2080411
1995-94	8.0L V10 (BR only)	R2080445

Note: From 1985-89, both roller and non-roller 5.2L & 5.9L engines were used in trucks and vans. For 1988, both roller and non-roller 3.9L were used in trucks and vans.  
Please be sure and specify the correct application when ordering these engines

## VIPER

MODEL YEARS	APPLICATION	REMAN PART NO.
1992-1995	Viper V-10 Long Block	R1080425AA
1996-1996.5	Viper V-10 Long Block	R1080466AA

# LONG BLOCK / SHORT BLOCK ENGINES



## JEEP®

MODEL YEARS	APPLICATION/ENGINE DISPLACEMENT	REMAN PART NO.
2002	2.4L KJ DOHC	R2424722AA
2002-91	2.5L Jeep (XJ, YJ, ZJ Bodies)	R2425319AA
1990-87	2.5L Jeep (XJ, YJ, ZJ Bodies)	R2425360AA
2004	3.7L V-6 KJ (with NGC Controller)	R2637044
2003 - 02	3.7L V-6 KJ (with JTEC Controller)	R2637023
2004-00	4.0L Jeep (TJ Body)	R2640492AA
2004-99	4.0L Jeep (WJ Body)	R2640492AA
2001-00	4.0L Jeep (XJ Body)	R2640402AB
1999-96	4.0L Jeep (all except '99 Grand Cherokee)	R2640469AB
1995-92	4.0L Jeep (XJ, YJ, ZJ Bodies)	R2640424AA
1991	4.0L Jeep (XJ, YJ, ZJ Bodies)	R2640411AA
1990-87	4.0L Jeep (XJ, YJ, ZJ Bodies)	R2640470AA
2004-02	4.7L SOHC V8 WJ (High Output)	R2847424
2002-99	4.7L SOHC V8 WJ	R2847014
1998	5.2L Magnum	R2852480
1997-92	5.2L Magnum	R2852424
1998	5.9L V8 Magnum	R2859488
1991-79	5.9L AMC (J, SJ Bodies)	JR527299AA

## SHORT BLOCK ENGINES

MODEL YEARS	APPLICATION/ENGINE DISPLACEMENT	REMAN PART NO.
2001-92	4.0L Jeep (XJ Body)	R9640421AA
1999-92	4.0L Jeep (YJ Body)	R9640421AA
1998-92	4.0L Jeep (ZJ Body)	R9640421AA
2003-92	5.2L Magnum	R9852422
2003-02	5.9L Magnum (DR only)	R9859423
2003-93	5.9L Magnum	R9859488



# CYLINDER HEADS



## PASSENGER CARS

MODEL YEAR	APPLICATION/ENGINE DISPLACEMENT	CAMSHAFT	REMAN PART NO.
2005-00	2.0L SOHC Fed, LEV	Yes	R5420402
2004-02	2.0L SOHC R/T	Yes	R5420524
2001	2.0L SOHC R/T	Yes	R5420511
1999-96	2.0L SOHC Fed, LEV, TLEV	Yes	R5420469
1999-95	2.0L DOHC (rear exhaust w/valves)	No	R5420659
1999-94	2.0L DOHC (front exhaust w/valves)	No	R5420649
1995-94	2.0L SOHC 16V (ECB/ECH)	Yes	R5420445
1995-88	2.2L rollers (EFI)	Yes	R5504082
1990-89	2.2L Turbo IV, rollers	Yes	R5504102
1988	2.2L Turbo, rollers	Yes	R5522188
1987	2.2L Turbo II (high swirl)	Yes	R0553077
1987-86	2.2L Turbo I (high swirl)	Yes	R0552067
1985	2.2L Turbo I	Yes	R0552155
1984-83	2.2L Carb. E, G, H, K, L Bodies	Yes	R0550937
2002	2.4L JR, PT Bodies w/EGR	No	R5424822
2002	2.4L PT w/o EGR	No	R5424611
2001	2.4L JR w/o EGR	No	R5424611
2000-95	2.4L DOHC (rear exhaust w/valves)	No	R5424650
2000-98	2.5L SOHC (rear, right) V6	Yes	R6625480
2000-98	2.5L SOHC (front, left) V6	Yes	R5625480
1997-95	2.5L SOHC (rear, right) V6	Yes	R6625457
1997-95	2.5L SOHC (front, left) V6	Yes	R5625457
1995-88	2.5L Rollers (EFI)	Yes	R5504082
1995-93	2.5L Flex fuel, rollers (EFI)	Yes	R5504935
1994-89	2.5L Turbo, rollers	Yes	R5504102
1989-88	2.5L Turbo II, rollers	Yes	R5504102
1987-86	2.5L TBI (high swirl)	Yes	R0551067
2004-01	2.7L DOHC JR Body (right)	No	R6627002
	2.7L DOHC JR Body (left)	No	R5627002
2004-00	2.7L DOHC LH Body (right)	No	R6627002
	2.7L DOHC LH Body (left)	No	R5627002
1999-98	2.7L DOHC LH Body (right)	No	R6627089
	2.7L DOHC LH Body (left)	No	R5627089
1997-87	3.0L (w/valves and springs)	No	RM553087
2004-98	3.2L/3.5L SOHC (w/valves and springs)	No	R5635488
1997-93.5	3.3L and 3.8L (head casting no. 4621510)	No	R5633436
1993.5-90	3.3L and 3.8L (head casting no. 4448015)	No	R5633403
1997-95	3.5L LH Body (left)	Yes	R5635457
1997-95	3.5L LH Body (right)	Yes	R6635457
1994-93	3.5L LH Body (left)	Yes	R5635434

# CYLINDER HEADS

(CONTINUED)



## MINIVANS

MODEL YEAR	APPLICATION/ENGINE DISPLACEMENT	CAMSHAFT	REMAN PART NO.
1995-88	2.2L Rollers (EFI)	Yes	R5504082
1989	2.2L Turbo, rollers	Yes	R5522188
1987-86	2.2L Carb. (high swirl) S Body	Yes	R0550067
1984	2.2L Carb. AS Body	Yes	R0550937
2002	2.4L RS w/EGR	No	R5424822
2001	2.4L RS	No	R5424611
2000-95	2.4L DOHC (rear exhaust)	No	R5424650
1995-88	2.5L Rollers (EFI)	Yes	R5504082
1990-89	2.5L Turbo, rollers	Yes	R5504102
1987-81	2.6L w/2 valve head	Yes	R5426017
1987-81	2.6L w/3 valve head, jet valve	Yes	R5426117
2000-87	3.0L (w/valves and springs)	No	RM553087
2003-01	3.3L/3.8L	No	R5633411
2002-01	3.3L/3.8L	No	R5633411
2000-98	3.3L/3.8L (head casting no. 4694183)	No	R5633480
1997-94	3.3L NGV (head casting no. 4621510)	No	R5633947
1997-93.5	3.3L/3.8L (head casting no. 4621510)	No	R5633436
1993.5-90	3.3L/3.8L (head casting no. 4448015)	No	R5633403

# CYLINDER HEADS

(CONTINUED)

## TRUCKS, VANS AND JEEP®

(COMPLETE EXCEPT FOR ROCKER ARMS AND CYLINDER HEAD GASKET)

MODEL YEAR	APPLICATION/ENGINE DISPLACEMENT	REMAN PART NO.
1987-86	2.2L Carb. (high swirl) AN Body	R0550067
1995-88	2.2L/2.5L Rollers	R5504082
2002	2.4L KJ	R5424822
2002-96	2.5L Dakota	R5625479
2002-87	2.5L Jeep	R5625479
2004-02	3.7L V-6 (left)	R5637022
2004-02	3.7L V-6 (right)	R6637022
2003-98	3.9L V6 Magnum (truck & van only)	R5639480
1997-92	3.9L V6 Magnum (truck & van only)	R5639426
1991-86	3.9L V6	R5639261
2004-00	4.0L Jeep TJ, XJ	R5640494
2004-99	4.0L Jeep WJ	R5640494
1999-96	4.0L Jeep (all except 99 Grand Cherokee)	R5640469
1995-91	4.0L Jeep	R5640415
1990-87	4.0L Jeep	R5640470
2004-02	4.7L WJ high output (left)	R5847424
2004-02	4.7L WJ high output (right)	R6847424
2004-99	4.7L (left)	R5847099
2004-99	4.7L (right)	R6847099
2003-98	5.2L V8 Magnum	R5852480
1998-92	5.2L V8 Magnum (Jeep only)	R5852426
1997-92	5.2L V8 Magnum (truck & van only)	R5852426
1991-85	5.2L V8	R5852251
2003-98	5.9L V8 Magnum	R5852480
1998	5.9L V8 Magnum (Jeep only)	R5852426
1997-93	5.9L V8 Magnum (truck & van only)	R5852426
1992-75	5.9L V8	R5859292
2003-94	8.0L V10	R5080433

# TURBOCHARGERS

## PRODUCT FEATURES:

- Completely new center housing rotating assemblies includes bearings and wheels
- All remanufactured turbochargers contain 360 degree water-cooled bearing housings

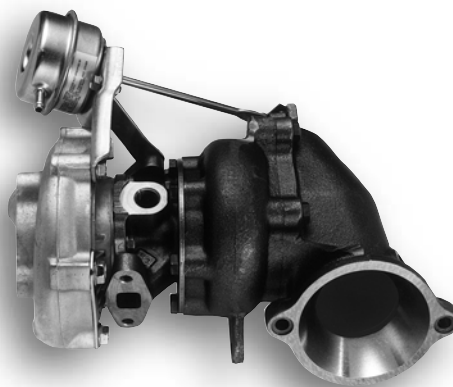

## PASSENGER CARS

MODEL YEAR	APPLICATION	O.E. PART NO.	REMAN PART NO.
1992	All 2.5L	04448992	R4448992
1991	All (except CA)	04448992	R4448992
1990	A, G, J & P Bodies, 2.5L (except CA)	04448992	R4448992
1989	A, G, H, J & P Bodies 2.2L Turbo w/o Intercooler (except CA)	04448992	R4448992
1988	All	04556016/04387235	R4556016

## MINIVANS

MODEL YEAR	APPLICATION	O.E. PART NO.	REMAN PART NO.
1990	AS Body, 2.5L (except CA)	04448992	R4448992
1989	AS Body, 2.2L Turbo w/o Intercooler (except CA)	04448992	R4448992

# TURBOCHARGERS

## KIT CONTAINS:

- Turbocharger
- Exhaust Flange Gasket
- Oil Line Gaskets

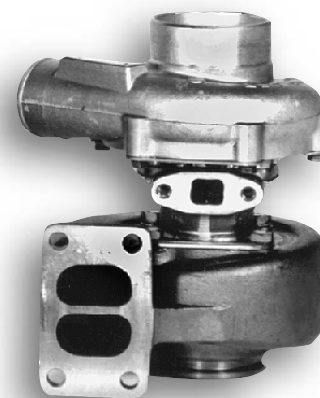

## CUMMINS-DIESEL APPLICATIONS

MODEL YEAR	ENGINE CPL	REMAN PART NO.
2006-04.5	8212, 8213, 8226, 8228, 8344, 8345, 8346, 8347, 8348, 8349, 8350, 8351, 8410, 8412, 8421, 8422, 8423, 8424	R5143256AA
2004-03	2426, 2998, 8128, 8212, 8213, 8223, 8224, 8226, 8228, 8229, 8410, 8411, 8412, 8413, 98293, 98294, 98329	R5086863AB
2002-00	2415, 2495, 2496, 2497, 2662, 2663, 2904, 2905, 2906, 2907, 8032, 8033, 8034, 8035 (235 HP M/T)	R5017509AA
2000-99	2616, 2617, 2618, 2619, 2660, 2661 (A/T)	R5014203AA
1998.5	2024, 2098, 2279, 2280, 2512, 2513, 2514, 2515	R5010961AA
1998-96.5	1863, 2308 (CARB)	R5010280AA
1998-96	2023, 2175 (M/T)	R5010278AA
1998-94	1816, 1968, 2022, 2174	R5010276AA
1995-94	1549, 1550, 1815, 1959	R5010960AA
1993-91.5	1351, 1579	R4728700
1991-89	804	R4728036

# WATER PUMPS

## PRODUCT FEATURES:

- New ceramic seals
- New bearings
- Each pump is 100% hub and bearing gauged to specifications and 100% vacuum tested



## IMPORT PASSENGER CARS AND MINIVANS

MODEL YEAR	APPLICATION	ENGINE	O.E. PART NO.	REMAN PART NO.
2000-97	NS Body	3.3L, 3.8L	05010898AA	R5010898AB
1998-95	LH Body	3.5L	05003085AA	R5003085AA
1997	LH Body	3.3L	05010897AA	R5010897AB
1996-91	AS Body	3.3L, 3.8L	04448878	R4448878
1996	NS Body	2.4L w/hydraulic tensioner	04621489	R4621489
1996-95	JA, JX Bodies	2.4L w/hydraulic tensioner	04621489	R4621489
1996-93	LH Body	3.3L	05281175	R5281175
1994-93	LH Body	3.5L	04882837	R4882837
1994-85	Colt	1500cc	MD997076	R0091093
1993-91	A, G Bodies	Turbo	04626682	R4626682
1993-91	G Body	2.2L 16-valve	04626682	R4626682
1990-81	Colt	1.4L, 1.5L	MD997076	R0091093
1989	All Passenger Cars	2.2L, 2.5L	04387457	R4798497
1989-82	All Passenger Cars	318 CID	04728533	R4728533
1989-70	All Passenger Cars	5.2L, 5.9L	03837641	R0091079
1988-81	All Passenger Cars	2.2L, 2.5L	04293898	R4293898
1987-78	All Passenger Cars	3.7L 225 CID	04131243	R0091065
1985-81	All Passenger Cars	2.6L	MD025190	R0091092
1979-72	All Passenger Cars	400, 440 CID	03780127	R0091080

# WATER PUMPS

(CONTINUED)

## TRUCKS

MODEL YEAR	APPLICATION	ENGINE	O.E. PART NO.	REMAN PART NO.
2000-93	All Trucks	3.9L, 5.2L, 5.9L	53021018	R3021018AD
1998-96	AN Body	2.5L	04626054	R4626054
1992-80	All Trucks (except 1991 Dakota w/5.2L) - use 04483754	5.2L, 5.9L	04728533	R4728533
1991-86	All Trucks	3.9L	03837641	R4728533
1988-81	All Trucks	2.2L, 2.5L	04293898	R4293898
1987-78	All Trucks	3.7L 225 CID	04131243	R0091065
1979-70	All Trucks	5.2L, 5.9L	03837641	R0091079

## JEEP®

MODEL YEAR	APPLICATION	ENGINE	O.E. PART NO.	REMAN PART NO.
2000-91	All Jeep	2.5L (all), 4.0L (YJ, ZJ)	04626054	R4626054
1998-91	All Jeep	5.2L, 5.9L	53008354/53020280	R3021018AD
1998-87	XJ, MJ Bodies	4.0L	04626215AF	N/A
1992-76	All Jeep	w/V8 eng. (305 & 360 CID)	J3234427	N/A
1989-87	MJ, XJ, J, SJ, YJ Bodies	2.5L w/serpentine belt, 4.2L w/serpentine belt	82775119	JR775047
1989-85	XJ Body	2.1L Turbo Diesel	T1461336	JR775056
1987-84	MJ, XJ Bodies	w/V6 GM	83500807	JR775049
1986-83	All Jeep	2.5L w/o serpentine belt	J9990807	JR775046
1986-83	All Jeep	233 CID, 258 CID w/o serpentine belt	J9990807	JR775046
1986-83	All Jeep, AMC engines	2.5L w/serpentine belt	J8134321	JR775047
1986-81	All Jeep	6-cyl. w/serpentine belt	J8134321	JR775047

## EAGLE

MODEL YEAR	APPLICATION	ENGINE	O.E. PART NO.	REMAN PART NO.
1997-93	Vision	w/3.3L	05281175	R5281175
1996-95	Vision	w/3.5L	04663296	R5003085AA
1994-93	Vision	w/3.5L	04556541	R4882837
1988-89	Premier	w/4-cyl.	04626215AF	N/A

# WATER PUMPS

(CONTINUED)

## AMC PASSENGER CARS

MODEL YEAR	APPLICATION	ENGINE	O.E. PART NO.	REMAN PART NO.
1988-81	AMC	6-cyl. w/serpentine belt	J8134321	JR775047
1986-83	AMC	4-cyl. w/o serpentine belt	J9990807	JR775046
1986-83	AMC	6-cyl. w/o serpentine belt	J9990807	JR775046
1984-83	AMC	4-cyl. w/serpentine belt	J8134321	JR775047
1979-76	AMC	V8	J3234427	N/A

### DIESEL PRODUCT FEATURES:

- Water Pump
- Gasket



## CUMMINS-DIESEL APPLICATIONS

MODEL YEAR	ENGINE CPL	REMAN PART NO.
2006-03	2624, 2998, 8212, 8213, 8218, 8223, 8224, 8226, 8228, 8346, 8347, 8350, 8351, 8410, 8411, 8412, 8413, 8421, 8422, 8423, 8424, 8624	R5086959AA
2002-98.5	2024, 2098, 2279, 2280, 2415, 2495, 2496, 2497, 2512, 2513, 2514, 2515, 2616, 2617, 2618, 2619, 2660, 2661, 2662, 2663, 2865, 2866, 2902, 2903, 2904, 2905, 2906, 2907, 8030, 8031, 8032, 8033, 8034, 8035 (all 24-valve engines)	R5010964AA
1998-89	804, 1351, 1549, 1550, 1579, 1815, 1816, 1863, 1959, 1968, 2022, 2023, 2174, 2175, 2308 (all 12-valve engines)	R5003665AA